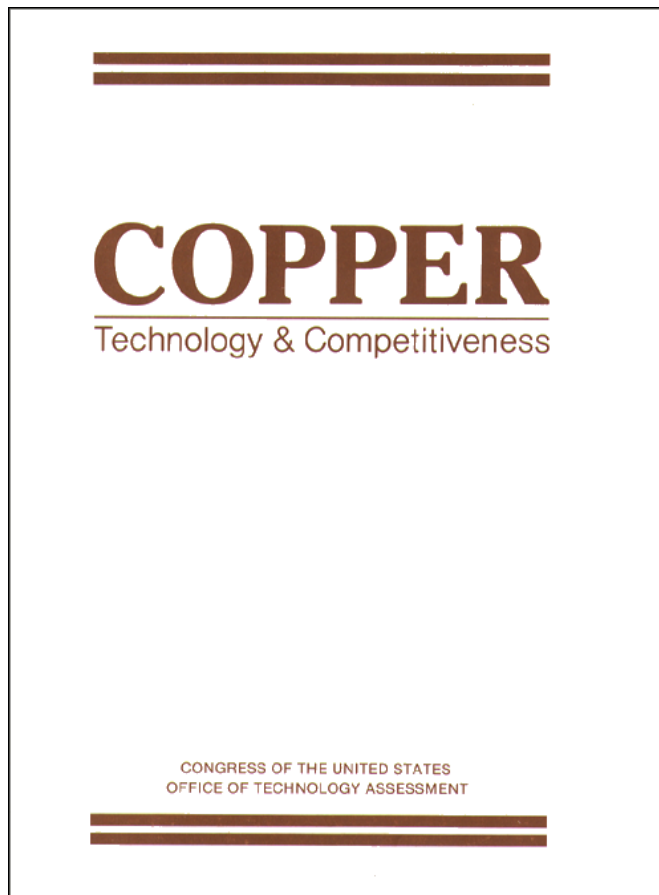


*Copper: Technology and Competitiveness*

September 1988

NTIS order #PB89-138887



Recommended Citation:

U.S. Congress, Office of Technology Assessment, ***Copper: Technology and Competitiveness***, OTA-E-367 (Washington, DC: U.S. Government Printing Office, September 1988).

Library of Congress Catalog Card Number 87-619893

For sale by the Superintendent of Documents  
U.S. Government Printing Office, Washington, DC 20402-9325  
(order form can be found in the back of this report)

## Foreword

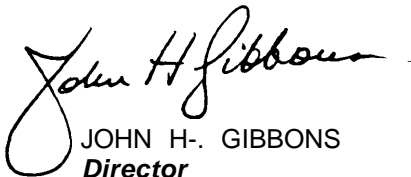
The discovery of copper by primitive people provided a transition from the Stone Age to the Metal Ages (Copper, Bronze, and Iron). For thousands of years, copper remained important for making tools, weapons, jewelry, and objets d'art. It was not until the Industrial Revolution and the age of electricity, however, that copper's excellent electrical conductivity stimulated a demand for a highly developed copper industry. The ancient mines were completely swamped by the increased world demand. But the westward expansion in North America led to the discovery of copper deposits that met much of this demand and made the United States the world leader in copper production for over a century.

Although copper markets historically have been volatile, exhibiting wide swings in supply and price with the opening of new mines and with general economic conditions, the U.S. industry had always managed to maintain its leadership. During the early 1980s, however, the global economic recession combined with the opening of numerous mines throughout the world to create oversupplies and low prices that called into question the survival of the domestic copper industry. Many U.S. mines and plants closed or cutback production. Over 28,000 jobs were eliminated. Producers sustained heavy financial losses and had to adopt aggressive cost-cutting programs.

This report responds to a request from the Technology Assessment Board—the congressional oversight body for the Office of Technology Assessment (OTA)—prompted by the balance-of-trade and other economic implications of these events. The report describes the conditions the domestic and world copper industry faced during the early 1980s. It documents the steps U.S. copper companies took to improve their position so dramatically in the mid-1980s, and evaluates the industry's present and possible future status, including relative costs of production and the elements of those costs.

The report concludes that the revitalized U.S. copper industry can compete in all but the worst foreseeable markets. Notably, the industry's turnaround came entirely from its own efforts; the Federal government rendered little assistance. The U.S. industry is now smaller, but it is still the world leader in smelter and refinery production, and ranks second in mine production. Its costs, though not the lowest in the world, are now low enough to weather most price swings. However, should the adverse conditions of the early 1980s recur, copper prices might fall to levels at which some domestic producers will again be unable to compete. The Report analyzes options available to the Federal government (and industry) to enhance the industry's competitive position.

Substantial assistance was received from many organizations and individuals in the course of this study. We would like to express special thanks to the OTA advisory panel, the project's consultants, the U.S. Bureau of Mines, and the many reviewers whose comments helped to ensure the completeness and accuracy of the report.



JOHN H. GIBBONS  
*Director*

# OTA Copper Advisory Panel

George S. Ansell, **Chairman**  
President, Colorado School of Mines

Richard Ayres  
Senior Staff Attorney  
Natural Resources Defense Council

Paul Biderman  
Secretary, Department of Energy and Minerals  
State of New Mexico

Corale L. Brierley  
president  
Advanced Mineral Technologies Inc.

Erling Brostuen<sup>2</sup>  
Secretary, Department of Energy and Minerals  
State of New Mexico

Henry Cole  
Senior Staff Scientist  
Clean Water Action Project

Robert Dimock  
Vice President, Gold Division<sup>3</sup>  
BP Minerals America

William H. Dresher  
president  
International Copper Research Association

John A. Hansen  
Department of Economics  
State University of New York at Fredonia

James G. Hascall  
president  
Olin Brass

John Kelly<sup>4</sup>  
General Motors Corp.

Robert H. Lesemann  
president  
CRU Consultants Inc.

Larry G. Lewallen<sup>5</sup>  
president  
AT&T Nassau Metals

Robert J. Muth  
Vice President  
Asarco, Inc.

William G. Pariseau  
Department of Mining Engineering  
University of Utah

Michael Rieber  
Department of Mining Engineering  
University of Arizona

Thomas D. Schlabach  
Department Head  
AT&T Bell Laboratories

Joel Secoy<sup>6</sup>  
AT&T Nassau Metals

Jack E. Thompson  
Tucson, Arizona

Mikon Wadsworth  
Dean, School of Mines  
University of Utah

Russell L. Wood  
President  
Copper Range Co.

---

<sup>1</sup>Until January 1987.

<sup>2</sup>After January 1987.

<sup>3</sup>Formerly Vice President, Technology

<sup>4</sup>Retired 1987.

<sup>5</sup>Until October 1986.

<sup>6</sup>After October 1986.

NOTE: OTA appreciates and is grateful for the valuable assistance and thoughtful critiques provided by the advisory panel members. The panel does not, however, necessarily approve, disapprove, or endorse this report. OTA assumes full responsibility for the report and the accuracy of its contents.



# OTA Copper Project Staff

Lionel S. Johns, *Assistant Director, OTA  
Energy, Materials, and International Security Division*

Peter D. Blair, *Energy and Materials Program Manager*

**Jenifer Robison, *Project Director***

## **Project Staff**

Vickie Basinger Boesch, *Industry and Market Structure*

John Newman, *Production Costs*

Margaret Passmore, *Environment/ Aspects and Energy Use*

## **Consultant**

Curtis Seltzer

## **Administrative Staff**

Lillian Chapman, *Administrative Assistant*

Linda Long, *Administrative Secretary*

Phyllis Brumfield, *Secretary*

## Acknowledgments

We are grateful to the many individuals who shared their special knowledge, expertise, and information about the copper industry, copper markets, and production technology with the OTA Staff in the course of this study. Others provided critical evaluation and review during the compilation of the report. These individuals are listed in Appendix C of this report.

Special thanks go to the government organizations, corporations, and academic institutions with whom these experts are affiliated. These include:

American Mining Congress  
Arizona Mining Association  
Asarco, Inc.  
BP Minerals America  
Colorado School of Mines  
Copper Range Co.  
Cyprus Minerals, Inc.  
Inspiration Consolidated Copper Co.  
Phelps Dodge Corp.  
Resource Strategies Inc.  
Robison Clipping Service  
State of Arizona, Department of Mineral Resources

State of Montana, Bureau of Mining and Geology  
State of New Mexico, Department of Energy and Minerals  
State of Utah, Department of Natural Resources and Energy  
U.S. Bureau of Mines  
U.S. Environmental Protection Agency  
U.S. Geological Survey  
University of Arizona, College of Mines  
University of Utah, School of Mines

# Contents

	<i>Page</i>
Foreword . . . . .	iii
<b>part One: Introduction and Summary.</b> . . . . .	1
Chapter 1. Introduction and Summary . . . . .	5
<b>Part Two: Industry and Market Structure</b> . . . . .	35
Chapter 2. The Current Status of the World Copper Industry . . . . .	37
Chapter 3. The Business Structure of the Copper Industry . . . . .	43
Chapter 4. Market Structure . . . . .	61
<b>Part Three: Resources and Technology</b> . . . . .	87
Chapter 5. World Copper Resources . . . . .	91
Chapter 6. Copper Production Technology . . . . .	103
Chapter 7. Energy Use in the Copper Industry . . . . .	151
Chapter 8. Environmental Aspects of Copper Production . . . . .	159
<b>Part Four: Competitiveness</b> . . . . .	181
Chapter 9. Production Costs . . . . .	185
Chapter 10. Strategies for Future Competitiveness. . . . .	219
Appendix A. Acronyms and Abbreviations. . . . .	257
Appendix B. Glossary . . . . .	259
Appendix C. Acknowledgements. . . . .	263
Indexes. . . . .	267
General Index . . . . .	267
Copper Properties Index . . . . .	271

**Part One**

# **Introduction and Summary**

Chapter 1

# **Introduction and Summary**

# CONTENTS

	<i>Page</i>
Findings and Options . . . . .	9
Why Is The Domestic Copper Industry Important? . . . . .	9
How Competitive Is The Domestic Copper Industry Today? . . . . .	15
What Are The Likely Prospects for Future Competitiveness? . . . . .	20
What Can the Federal Government Do To Improve the Prospects for Competitiveness? . . . . .	+.. ..... 24
Option Set 1: Do Nothing . . . . .	25
Option Set 2: Protect the Industry From World Market Changes.. . . . .	26
Option Set 3: Promote Investments in Competitiveness . . . . .	27
What Can the Copper industry Do To Maintain or Improve Its Competitiveness? . . . . .	31

## Boxes

<i>Box</i>	<i>Page</i>
I-A. Copper Production. . . . .	7
I-B. The Costs of Smelter Pollution Control.. . . . .	20
I-c. What Happened to the Price of Copper?. . . . .	23
1-D The U.S.-Canada Free Trade Agreement . . . . .	26
I-E. Technological Innovation and R&D Needs . . . . .	33

## Figures

<i>Figure</i>	<i>Page</i>
1-1. Principal Stages of the Copper Production Process . . . . .	8
1-2. Flow Sheets for Copper Production . . . . .	9
1-3. Major World Copper Resources . . . . .	10
1-4. U.S. Copper Consumption by End-use Sector, 1986 . . . . .	11
1-5. The Copper Industry in 1986 . . . . .	12
1-6. Copper's Economic Impact in the State of Arizona, 1987 . . . . .	13
1-7. Major Sources of U.S. Copper Import% 1986 . . . . .	14
1-8. Average Net Operating Costs for Major Copper Producing Countries . . . . .	16
1-9. productivity in the U.S. Copper Industry: 1973-1986 . . . . .	19
1-10. Average price Compared With U.S. and Rest-of-World Refined Copper Production and Consumption . . . . .	19
1-11. Sulfur Dioxide Control . . . . .	21
1-12. Trends in U.S. Bureau of Mines R&D . . . . .	30

## Tables

<i>Table</i>	<i>Page</i>
I-1. Changes in the U.S. Copper Industry: 1981-86 . . . . .	17
I-2. Recent Government Acquisitions of Copper Capacity . . . . .	17
1-3. Strategies Adopted by U.S. Copper Companies in Response to Economic Conditions 1980-87 . . . . .	22
I-4. Copper Markets: 1983-87 . . . . .	24

# Introduction and Summary

---

**The early 1980s brought hard times to the domestic copper industry. Low prices and slack demand led to mine closings, worker layoffs, and financial losses, which in turn raised questions about the industry's viability. Copper producers responded by modernizing their equipment and cutting costs. By 1987, when prices began to rise, the U.S. industry was profitable again.** But what of the future? Copper prices historically have been cyclical, and undoubtedly will fall again. What steps need to be taken now for the domestic copper industry to survive another prolonged downturn? This assessment documents the industry's actions to improve its position so dramatically during the 1980s, evaluates its present—and possible future—competitive status, and discusses options available to Congress (and the industry) to prepare for the next market slump.

**Copper is the world's third most widely used metal (after iron and aluminum).** Its advantageous chemical, mechanical, and physical properties make it valuable in electrical and telecommunications products, building construction, industrial machinery and equipment, transportation, and consumer products. Copper's strategic uses include ordnance, command-communication-control-intelligence (C<sup>3</sup>I) systems, and military transportation and advanced weaponry systems,

**The industry that explores for, mines, smelts, refines, fabricates, markets, and recycles copper is of significant economic importance in its own right.** In 1979, when the U.S. copper industry was at its peak, it employed over 90,000 people, with total shipments of the industry's products exceeding \$10 billion.<sup>1</sup> Over 25 major mines, 17 smelters, and 22 refineries were in operation. The industry's contribution to gross national product (GNP) was more than \$6 billion, with almost 40 percent contributed by copper mining and

concentrating; 30 percent by smelters, refineries, and wire mills; and 30 percent by brass mills.<sup>2</sup>

Domestic and world copper consumption began to slide in 1979, and dropped even further during the ensuing recession. The price of copper peaked in 1980, then plummeted over 50 percent by the end of 1984. Despite the market slump, copper production in the rest of the world continued to increase, and world inventories ballooned. Furthermore, the strong U.S. dollar during this period favored imported copper.

By the mid-1980s, domestic mine production had fallen to its lowest level since the 1960s, and the United States lost its position as the world's leading copper producer for the first time in a century. From March 1981 to January 1983, 28 domestic mines closed or cut back production, and U.S. mine capacity utilization hovered around 65 percent. At the end of 1982, the industry had laid off about 42 percent of the total copper work force.

As a result, domestic copper companies lost a lot of money. Amoco Minerals lost nearly \$60 million on copper from 1981 to 1985; Asarco lost over \$384 million from 1982 to 1985; Phelps Dodge lost \$400 million between 1982 and 1984; and Kennecott lost over \$600 million between 1982 and 1985. Anaconda simply went out of business.

By 1985, the rest of the economy had rebounded from the recession, but the minerals industry lagged behind. Although demand exceeded world production and inventories began to decline, prices remained low. Only two U.S. copper firms reported profits from their operations, imports were at their highest since 1946, and domestic capacity utilization was still only 73 percent. Some previously closed mines re-

<sup>1</sup>Unless noted otherwise figures in this assessment are in nominal dollars and metric tonnes (1 metric tonne = 1.1 short ton = 2204.6 pounds).

<sup>2</sup>Louis Sousa, *The U.S. Copper Industry: Problems, Issues, and Outlook* (Washington, DC: U.S. Department of the Interior, Bureau of Mines, October 1981).

<sup>3</sup>Inventories are stocks of copper held at refineries and at commodity exchange warehouses awaiting shipment (or, for some copper, at refineries awaiting processing).

opened in 1985, but several major operations closed, including Bingham Canyon—the largest mine in the United States.

The balance-of-trade and other economic implications of these conditions prompted the Technology Assessment Board—the congressional oversight body for the Office of Technology Assessment (OTA)—to ask OTA to undertake a study identifying technical and economic issues related to the decline of the U.S. copper industry. Nine members of the Congressional Copper Caucus subsequently endorsed the request. In particular, the letter of request asked OTA to:

. . . address the entire structure of the industry, including mining, refining, and smelting technologies. Operational and institutional constraints should also be addressed. The study should also provide recommendations which can be implemented by both government and industry entities in revitalizing our domestic copper industry.

This assessment responds to that request. During the course of OTA's analysis, the U.S. copper industry began its phenomenal recovery from the ravages of 1981-84. In 1985, the price of copper rose slightly, demand remained strong, inventories began to shrink, and world copper production was closer to being in line with demand.

Industry management also took steps to improve their financial situation. They restructured assets and shed a lot of debt. Marginal cost producers either closed permanently or shut down on a long-term care and maintenance basis. The remaining operations cut costs across the board. Labor costs were reduced through wage rate cuts and productivity improvements. Companies made major capital investments at mines, smelters, and refineries to improve operating efficiency. Largely in response to low prices, domestic mines also increased their average ore grade from 0.48 percent to over 0.6 percent by closing marginal mines and changing the mine plans at others.

As a result of this restructuring and capital investment, the U.S. copper companies that survived the industry's depression are now profitable. Many industry analysts question how long this will last, however. **Although financially healthy, the companies are operating at the mar-**

**gin in the sense that they have closed high-cost mines, made most available capital investments in technology, and reduced labor and wage rates to a minimum.** Most analysts consider another price slump inevitable as new mines throughout the world come on line in the early 1990s. **If prices again stay low for several years, copper companies would have to find new means of reducing their costs further (other than closing facilities), or implement other strategies in order to remain competitive.**

Because of the improvements in the industry's condition, OTA structured this assessment around three basic questions aimed at assessing the industry's future. First, what is the present status of the domestic and world copper industry, including relative costs of production and the elements of those costs? Second, what did U.S. copper companies do in order to improve their position so dramatically in the mid-1980s? Third, what options will be available to Congress (and the domestic industry) to enhance their competitive position next time they face the conditions they experienced in the early 1980s?

This assessment is limited, for the most part, to the *primary* copper industry—that sector that mines copper ore and processes and refines it to produce 99.99+ percent pure copper. (Box 1-A provides a brief overview of the copper production processes, and defines the terms used by the industry. ) The assessment discusses the first stage in fabrication of copper products—the production of copper rod (the precursor of copper wire)—only to the extent that rod mills are integrated with other operations. It does not discuss the downstream fabrication of copper products (e.g., pipe, wire) except in the context of demand in various end-use sectors.<sup>4</sup>

This assessment also does not discuss recycling of copper except to note the extent to which copper scrap is used to meet total demand (i.e., it does not evaluate policy options related to recycling).<sup>5</sup> It also is limited to copper production and

<sup>4</sup>Note that most U.S. copper imports are in the form of semi-fabricated and fabricated products.

<sup>5</sup>An earlier OTA report discussed recycling of several important metals and materials; see U.S. Congress, Office of Technology Assessment, *Strategic Materials: Technologies To Reduce U.S. Import Vulnerability*, OTA-ITE-248 (Washington, DC: U.S. Government Printing Office, May 1985).



### Box I-A.—Copper Production

Copper is a reddish or salmon-pink metallic element. In ore, the copper usually is linked with sulfur (**sulfide ores**) or oxygen (**oxide ores**). Ores also contain other metals, including valuable **byproduct metals** (e.g., gold, silver, and molybdenum), and large quantities of valueless rock. Ore typically contains from 0.4 percent to 6 percent copper. For most applications, however, refined copper has to be 99.99+ percent pure. Therefore, a series of operations are performed that result in products with a successively higher copper content (see figures 1-1 and 1-2).

Copper ore may be mined by either **open pit** or **underground** methods, or the mineral values may be leached out of the ore (**solution mining**). Once the ore has been mined, the copper is extracted from it either by **leaching** (**hydrometallurgical** recovery) or through heat (**pyrometallurgical** methods). In hydrometallurgical processes, water or an acidic chemical solution percolates through the ore and dissolves the minerals. The copper is recovered from the resulting pregnant leachate either through **iron precipitation** or solvent **extraction**.

Pyrometallurgical processes employ high-temperature chemical reactions to extract copper. The ore is first pulverized by tumbling it with steel balls in cylindrical mills. The ground ore is then concentrated to eliminate much of the valueless material. The **concentrates** contain 20 to 30 percent copper. Depending on the copper minerals and the type of equipment, subsequent pyrometallurgical treatment of the concentrates may take as many as three steps: **roasting**, **smelting**, and **converting**. Roasting dries, heats, and partially removes the sulfur from the concentrate to facilitate smelting. The concentrates are smelted to produce a liquid copper **matte** (35 to 75 percent copper), plus slag (waste)<sup>1</sup> and sulfur dioxide gas. After smelting, the molten matte is converted into **blister copper** (98.5 to 99.5 percent copper), slag, and sulfur dioxide gas.<sup>2</sup> The molten blister is fire refined to further reduce its sulfur and oxygen content and poured into molds. When cooled, it is **anode copper**.

The final step in the purification process is electrolytic treatment, either through **electrowinning** of solvent extraction solutions or **electrolytic refining** of copper anodes. The end product, **cathode copper**, is 99.99+ percent copper. Cathodes are melted and cast into wirebars or continuous bar stock for wire manufacture, into slabs for mechanical use, or ingots for alloying.

<sup>1</sup>The slag from smelting and converting may be recycled to recover its copper content.

<sup>2</sup>It is called "blister" because bubbles of sulfur dioxide form on the surface of the copper during solidification.

consumption in the market economy countries (also termed the Non-Socialist World: or NSW).<sup>6</sup> A brief description of copper activities in the centrally planned countries is included at the end of chapter 4.

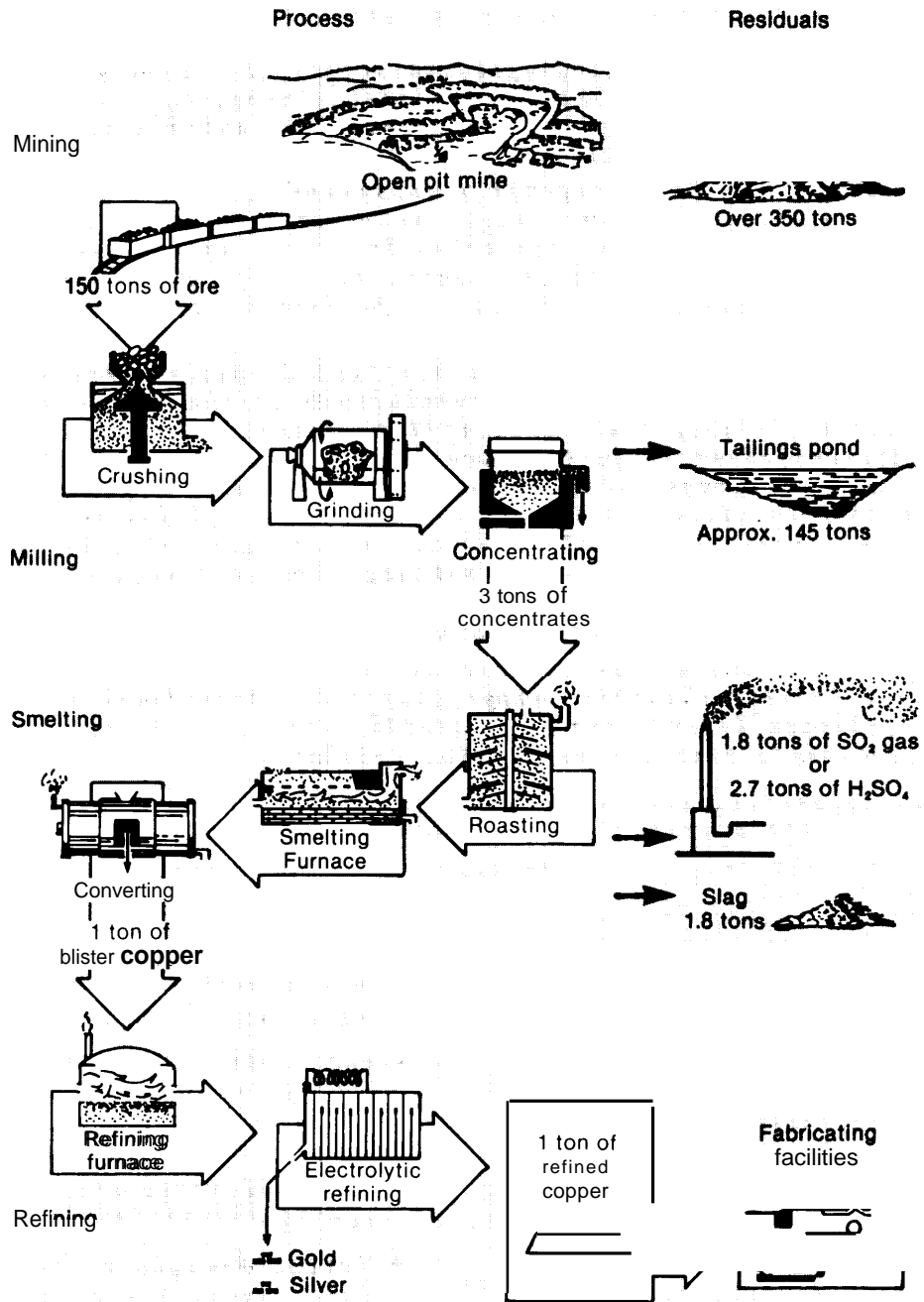
The assessment is organized as follows:

- the remainder of this chapter summarizes OTA's findings on these questions and presents options for Congress (and industry) to consider;

<sup>6</sup>The Non-Socialist World (NSW) refers to all copper producing and consuming market economy countries. This includes Yugoslavia, but excludes Albania, Bulgaria, Czechoslovakia, Cuba, Democratic Republic of Germany, Hungary, Poland, Romania, and the USSR. China also is excluded from consumption and production figures, but is included in trade figures because of the significant amount of copper imported into China from NSW countries in recent years.

- Part Two reviews the structure of the domestic and world copper industry and the status of copper markets (chs. 2-4);
- Part Three describes copper production, including the geology of copper deposits, technologies for mining and processing copper ores, and R&D needs for advanced technologies; and energy use and environmental controls in copper processing (chs. 5-8); and
- Part Four discusses the competitive status of the U.S. copper industry, including domestic and international production costs and the factors that influence them, measures of competitiveness and where the U.S. industry stands under each measure, and government policies and industrial strategies that affect competitiveness (chs. 9 and 10).

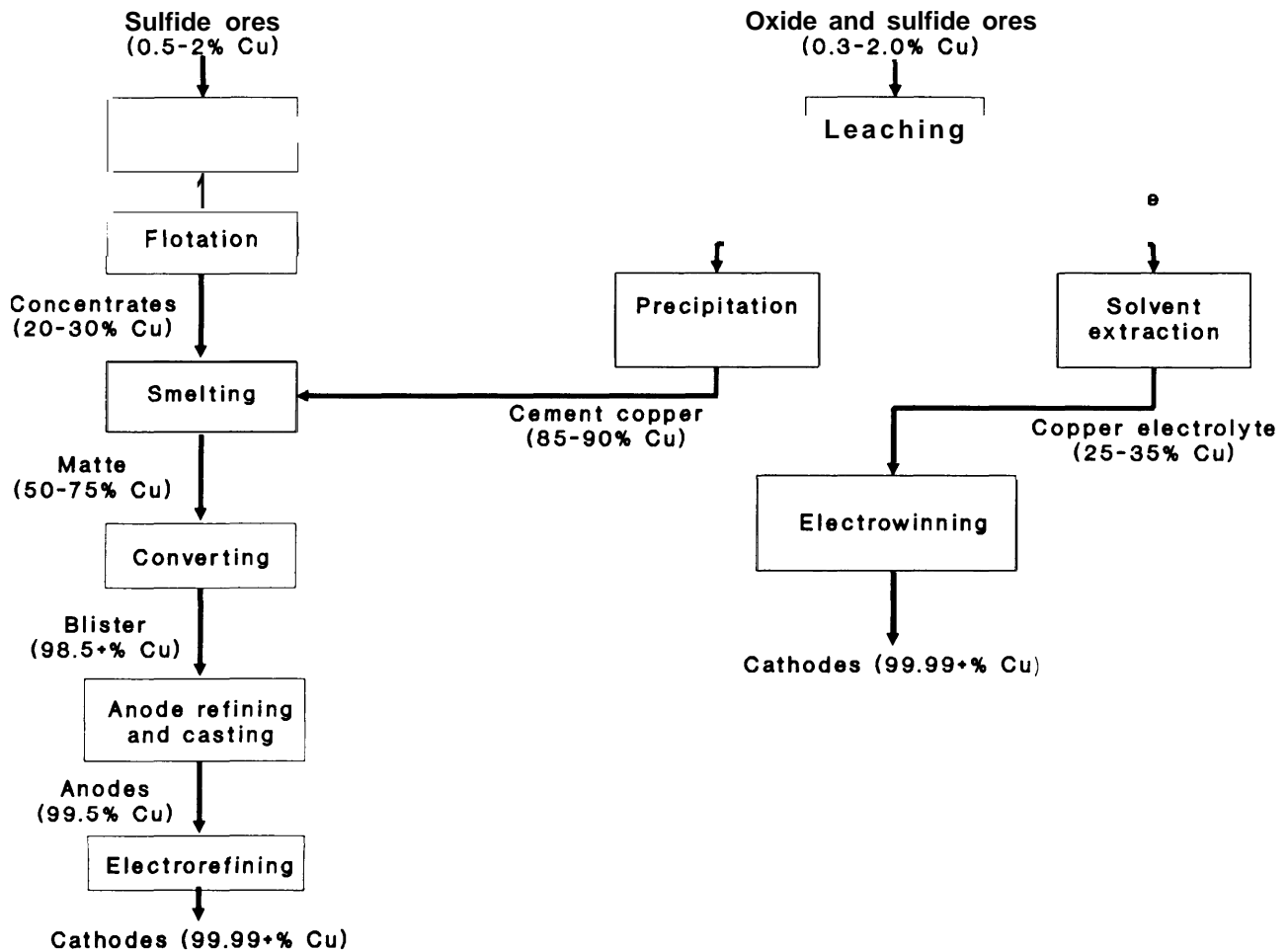
Figure 1.1 —Principal Stages of the Copper Production Process



NOTE: Tonnage of residuals is based on experience in the Southwestern United States assuming an ore grade of 0.6 per cent copper.

SOURCE: J F McDivitt and G Manners, *Minerals and Men* (Baltimore, MD: The Johns Hopkins University Press, 1974).

Figure 1-2.-Flow Sheets for Copper Production



SOURCE: Office of Technology Assessment.

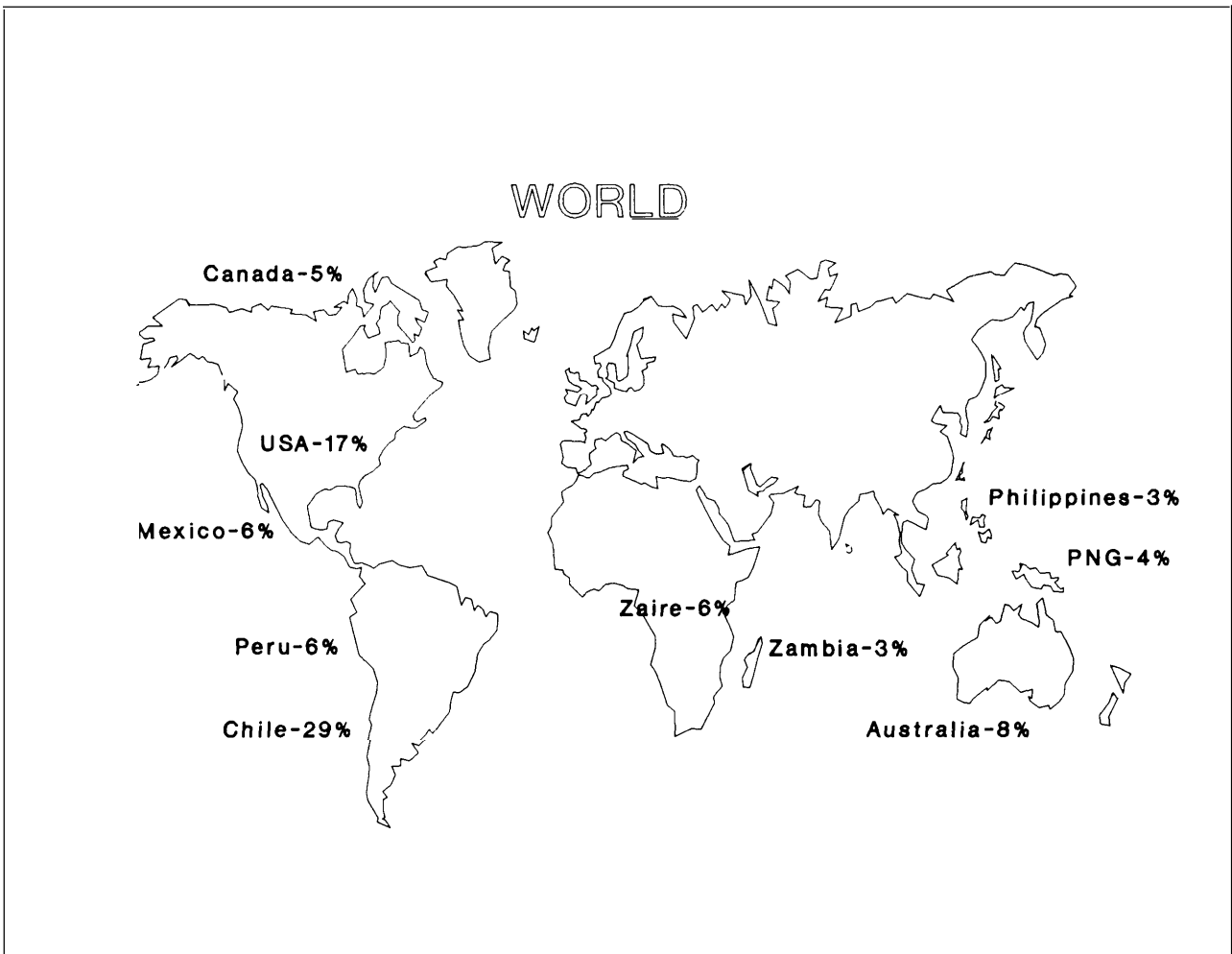
## FINDINGS AND OPTIONS

### Why Is The Domestic Copper Industry Important?

Copper conducts both heat and electricity very well. It is also strong, wear- and corrosion-resistant, and nonmagnetic. These properties make the metal and its alloys vital in nearly every industrial sector. Moreover, the copper industry contributes billions of dollars to gross national and regional products. Finally, copper is an important strategic metal.

In contrast with its importance, copper is a scarce metal. On average, the Earth's crust contains only 0.0058 percent copper, compared with 8 percent aluminum and 5.8 percent iron. Most commercial copper ore deposits today **contain** from 0.5 to 6 percent copper. Although the United States has one-fifth of the world's recoverable copper reserves (see figure 1-3), our ore grades are relatively low—averaging only 0.65 percent.

**Figure 1-3.-Major World Copper Resources**



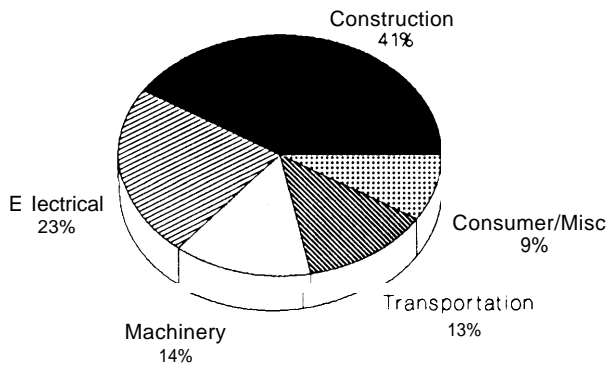
SOURCE" U S Bureau of Mines

### The Uses of Copper

In 1986, around 41 percent of copper mill products went to the construction industry (see figure 1-4). Uses there include electrical wiring, plumbing and heating, air-conditioning and refrigeration, and architectural applications (such as gutters and roof and wall cladding). The second largest market—23 percent—was the electrical and electronics industry for telecommunications, power utilities, industrial controls, business electronics, lighting and wiring, etc. Next

was the industrial machinery and equipment industry, with 14 percent of total shipments. Virtually all modes of transportation—automobiles, trucks, railroad equipment, aircraft and aerospace, and ships—contain copper. This sector accounted for almost 13 percent of domestic demand in 1986. Radiators, bearings, wiring, electronic devices, and brake linings are only a few of the auto and truck parts made with copper or copper alloys. Finally, miscellaneous consumer goods (ranging from appliances to cooking utensils to jewelry and objets d'art), military ap-

Figure I-4. -U.S. Copper Consumption by End-use Sector, 1986



SOURCE: Copper Development Association

placations, coinage, pharmaceuticals, and chemicals accounted for around 9 percent of consumption in 1986.<sup>7</sup>

**Copper's uses—and the industry's fortunes—vary over time.** When copper prices remain high for extended periods, some consumers may switch to other metals instead (e. g., aluminum for architectural uses and some wiring). Other substitutions arise from performance considerations (for instance, aluminum in car radiators to reduce weight), or from technological change (fiber optics for telecommunications). When copper consumption drops and prices are low, as happened during the 1982 to 1983 recession, the U.S. copper industry has trouble competing in world markets.

### The Economic Importance of the Primary Copper Industry

In 1986, the United States mined 1.15 million tonnes of copper at 87 mines located in 12 States.<sup>8</sup> At 61 of these mines, copper was the primary product, and at the other 26 it was a by-product of gold, silver, lead, or zinc mining. Fifteen percent of the copper concentrate produced

<sup>7</sup>Copper Development Association, "Copper and Copper Alloy Mill Products to U.S. Markets—1 986," *CDA Market Data*, May 10, 1987.

<sup>8</sup>Due to low ore grades in the United States, the domestic industry mined 170 million tonnes of ore to produce the 1.15 million tonnes of copper.

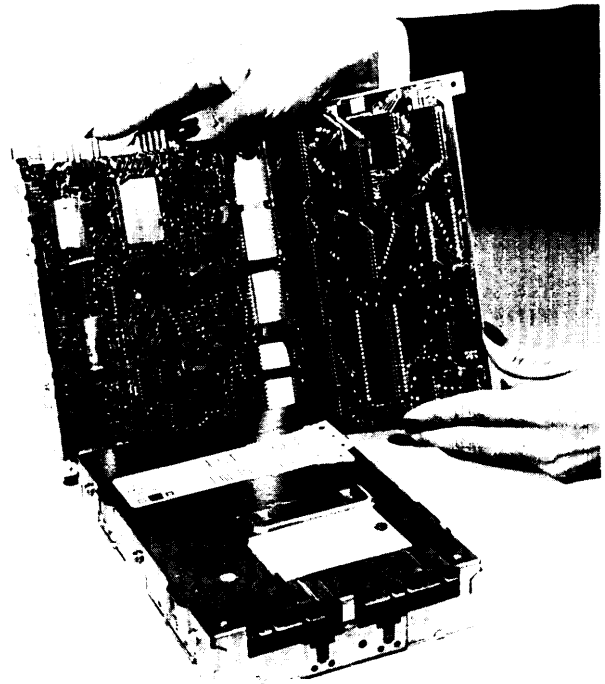


Photo credit: General Motors

Microcomputer for controlling an automobile engine. Over the last two decades, copper use in the electrical and electronics industry has increased significantly due to the growth of electronic devices in computers and telecommunications, consumer products, automobiles, and control devices.

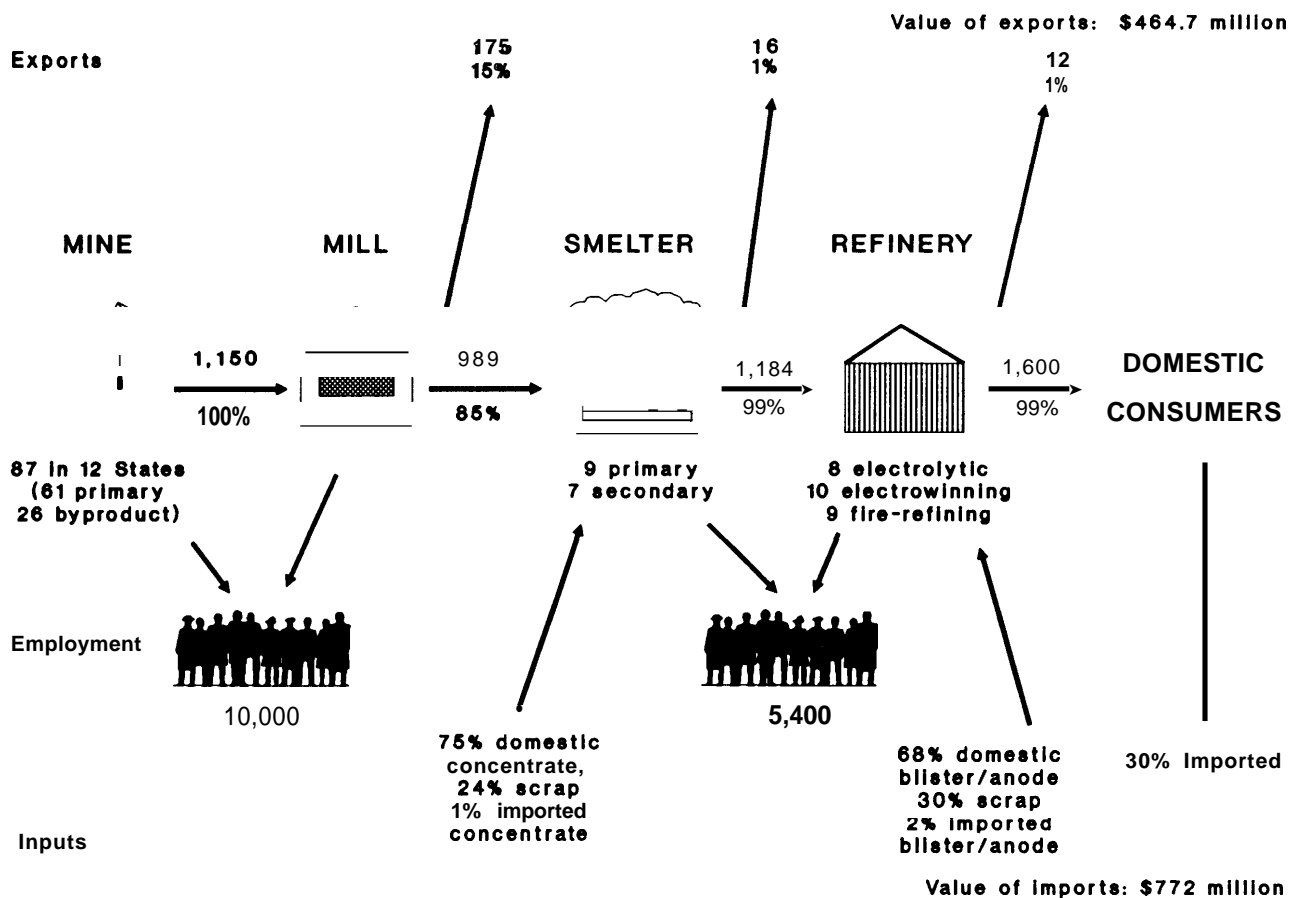
domestically (containing 174,350 tonnes of copper) was exported (see figure 1 -5). Nine primary and seven secondary smelters operated in 1986,9 producing almost 1.2 million tonnes of blister copper—903,000 tonnes from domestic concentrates, 288,000 tonnes from scrap, and 5,000 tonnes from imported concentrates. Twenty-four domestic refineries turned out nearly 1.5 million tonnes of refined copper in 1986, including over 125,000 tonnes from electrowinning plants. Around 27 percent of domestic refinery output was from scrap, and 2 percent was from imported blister and anode.<sup>10</sup> Refined copper imports increased 33 percent in 1986; U.S. net import reliance<sup>11</sup> was 27 percent.

<sup>9</sup>One primary and one secondary smelter closed permanently in 1987.

<sup>10</sup>Janice L. W. Jolly and Daniel Edelstein, "Copper," preprint from 1986 *Bureau of Mines Minerals Yearbook* (Washington, DC: U.S. Department of the Interior, Bureau of Mines, 1987).

<sup>11</sup>AS a percent of apparent consumption; defined as imports - exports + adjustments for Government and industry stock changes.

Figure 1-5.-The Copper Industry in 1986  
(production numbers in 1000 metric tonnes)



SOURCE: OTA from U.S. Bureau of Mines data.

The value of primary copper produced from domestic ores was \$1.67 billion. U.S. exports of concentrates, blister, refined products, and scrap were valued at \$464.7 million, while imports of these products into the United States were worth \$772 million.<sup>12</sup> To produce these products, the primary copper industry employed over 10,000 mine and mill workers and 5,400 smelter and refinery employees.

With this magnitude of production and employment, each copper operation contributes substantially to the local and regional, as well as the national, economy. Operations in

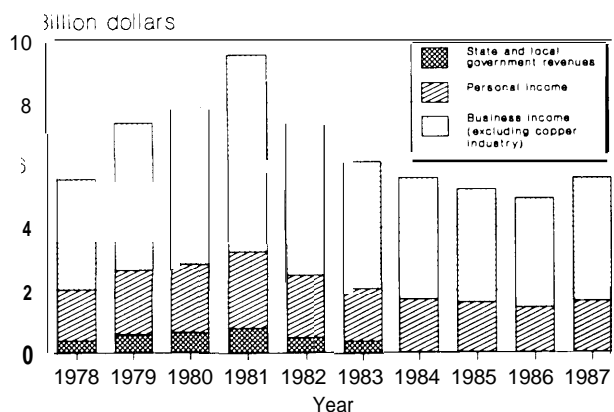
Arizona—which produce nearly two-thirds of the Nation's copper—contributed \$5.8 billion to the State's economy in 1987. Despite the industry's continued recovery, this was still far below the peak contribution of \$9.6 billion in 1981 (see figure 1-6). Revenues to State and local government from severance, property, payroll, and sales taxes totaled \$56 million; equipment and other supplies sold to the copper industry by Arizona firms were \$608 million; and total wages and salaries equaled \$292 million.<sup>13</sup>

The economic impact of just one mine is shown in the Copper Range Company's estimate that the

<sup>12</sup>Jolly and Edelstein, supra note 10.

<sup>13</sup>Richard Ducote, "Copper's Impact in State Put at \$5.8 billion for '87," *The Arizona Daily Star*, July 27, 1988.

Figure 1-6.-Copper's Economic Impact in the State of Arizona, 1987



SOURCE Richard Ducote. "Copper's Impact in State Put at \$5.8 Billion to '87," *The Arizona Daily Star* July 27, 1986

1986 reopening of the White Pine Mine on Michigan's upper peninsula would contribute \$38 million to the economies of three counties during the first year of operation. The mine employed 900 people, adding \$18 million to personal income. The analysis projected that mine employees would spend \$13 million in retail sales, generating 63 new retail establishments, and creating 576 new non-manufacturing jobs. The mine itself paid \$32.3 million directly to vendors during its first year.<sup>14</sup>

The recent contraction of the domestic copper industry also had significant impacts on local and regional economies. permanent closure of the Douglas, Arizona smelter in January 1987 cost the town 344 direct jobs with an annual payroll of \$10 million. Throughout Cochise County, up to 680 jobs eventually could be affected, totaling another \$11.8 million in lost earnings. In addition to lost jobs and earnings, the sparsely populated county lost one of its major sources of tax revenue; the smelter paid \$314,000 in property taxes alone in 1986.<sup>15</sup>

Cutbacks in the copper industry also affect the fortunes of its suppliers. For example, the U.S.

mining machinery industry experienced substantial excess capacity due to many of the same problems that affected the minerals industry, including reduced mineral demand during the first half of the 1980s, the strong dollar during the same period, and increased competition from imports. Although mining machinery firms have undertaken significant cost reduction measures to remain competitive (including closing plants), several companies have gone out of business.<sup>16</sup>

## The Strategic Importance of Copper

Copper is a strategic material—it is essential in the production of equipment critical to the U.S. economy and the national defense. The Department of Commerce estimates that military consumption of copper for ordnance has ranged from 10 percent of total U.S. demand at the height of the Vietnam War to around 1.5 percent during peacetime. In addition, copper wire is a critical component of all command-communication-control-intelligence (C<sup>3</sup>I) systems. Military transportation and advanced weaponry systems also use significant quantities of copper. Finally, the vast industrial base that supports the national defense requires machinery and goods containing copper.<sup>17</sup>

In 1986, U.S. refined copper imports were around 24 percent of refined consumption. This is roughly equal to the copper used by the electrical and electronics industry in 1986. The principal sources of imports were Chile, Canada, Peru, Zambia, and Zaire (see figure 1-7).<sup>18</sup> While neither political instability nor hostility is a major concern about the security of supplies from these countries, their imports can be subject to disruption (e.g., due to labor strikes or insecure transportation routes).

As a result, copper is included in the National Defense Stockpile. The current stockpile goal is 1 million short tons. In 1986, the inventory was 22,297 short tons of copper, plus 6,751 short tons

<sup>14</sup>Jolly and Edel Stein, *supra* note 10.

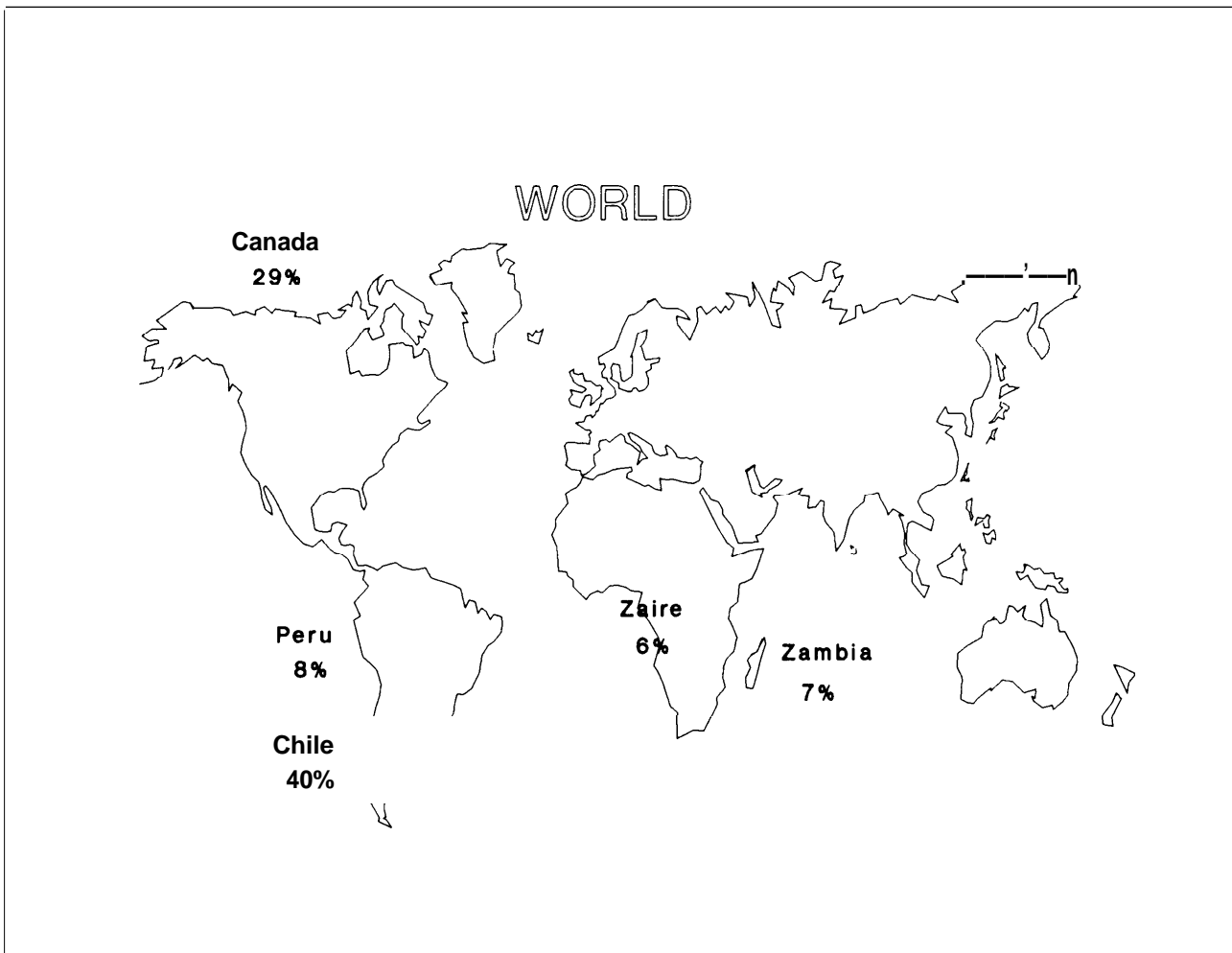
<sup>15</sup>Anthony Opyrchalet et al., *The Changing Role of the Nonfuel Minerals Industry in the State and Local Economies of Arizona (1981-1986)* (Washington, DC: U.S. Department of the Interior, Bureau of Mines, 1987).

<sup>16</sup>International Trade Administration (ITA), *A Competitive Assessment of the U.S. Mining Machinery Industry* (Washington, DC: U.S. Government Printing Office, 1986).

<sup>17</sup>Sousa, *supra* note 2.

<sup>18</sup>Janice L.W. Jolly and Daniel Edelstein, "Copper," *Mineral Commodity Summaries: 1987* (Washington, DC: U.S. Department of the Interior, Bureau of Mines, 1987).

Figure 1-7.-Major Sources of U.S. Copper Imports, 1986



SOURCE: U.S. Bureau of Mines data.

of copper contained in 9,645 short tons of brass.<sup>19</sup> over the years stockpile purchases and releases have affected copper supply and price. For example, from 1959 to 1963 stockpile acquisitions combined with copper industry strikes and strong economic expansion to push prices upward.<sup>20</sup>

The stockpile inventory shortfall often has attracted congressional attention as a means of prodding sluggish markets. Most recently, legislation was introduced in the 98th Congress (1983

<sup>19</sup>ibid.

<sup>20</sup>U.S. Department of the Interior, Bureau of Mines, *Minerals Yearbook*, various years.

to 1984) to purchase copper for the National Defense Stockpile. Opponents argued that the proposed acquisitions were insufficient to reopen any shutdown operations, and would have established a precedent of allowing economic considerations to supersede defense needs.

Purchasing domestic copper for the stockpile when demand and prices are low could help the industry bridge these difficult periods without having to close facilities. Bringing the stockpile up to its goal of 1 million tons, however, would require the purchase of almost 971,000 tons of copper. This is equivalent to 90 percent of 1986



U.S. primary refinery production, and 15 percent of world production. Even if spread over several years, such purchases could have far-reaching and unintended effects on copper production unless world inventories were very high. It also could cost as much as \$2 billion, depending on the price of copper.

### How Competitive Is The Domestic Copper Industry Today?

International competitiveness is the ability of companies in one country to produce and sell products in rivalry with those in other countries. American industries and companies also compete among themselves for markets and for resources such as investment capital and quality employees. In its simplest sense, competitiveness is measured by comparing countries' or firms' costs of production and thus profitability. Other measures may consider market share and resource endowments (e.g., ore reserves, capital, or technology),

**The copper industry has rebounded from the hardships it endured in the early 1980s, but at the cost of significant restructuring. Domestic companies cut their production costs substantially and now are profitable.** The average U.S. net operating cost in 1986 was approximately 54 cents/lb, down from a 1981 level of between 80 and 90 cents/lb. Costs in other major producing countries averaged around 45 cents/lb in 1986 (see figure 1-8). The average domestic producer price in 1986 was 66.05 cents/lb, and the price on the London Metal Exchange averaged 62.28 cents/lb.<sup>21</sup>

**The industry achieved part of these cost reductions through capital investments and other positive actions (e.g., revised mining plans; see below) that greatly increased domestic productivity. The remainder came from the permanent closure of high-cost facilities. Today, the U.S. industry as a whole is smaller. There are fewer firms producing copper at fewer operations with fewer employees (see table 1-1 ),**

**This does not mean the United States is no longer a major player in the world copper industry. We are still the world leader in smelter and refinery production, and rank second in mine production. Expansion throughout the world industry has substantially altered our market share, however (table 1-1 ).** The domestic share of world mine/mill and refinery output declined 24 percent from 1981 to 1986; smelter share dropped 31 percent. In contrast, U.S. consumption as a percent of world demand remained constant. As a result, **U.S. net import reliance grew from 6 percent in 1981 to 27 percent in 1986,**

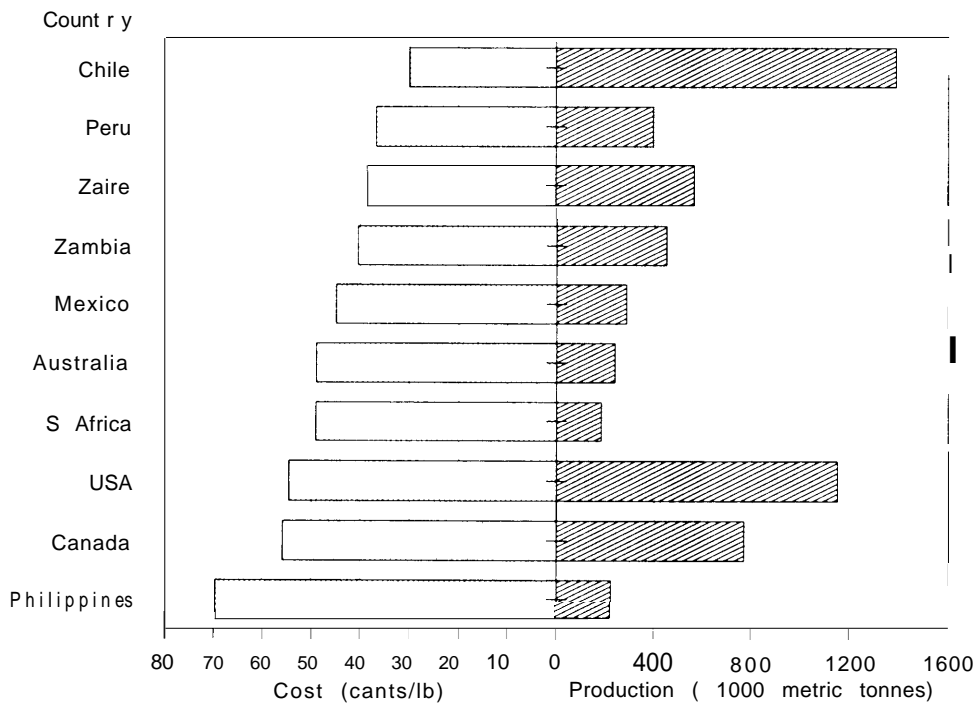
Losses in market share for industrialized countries are inevitable as other nations develop their resources. However, they do mean less market power. In the copper industry, nationalizations of many operations compounded the market trend (see table 1-2). Because they no longer own and/or control output at those operations, American companies lost much of their ability to influence world production in response to changes in price and demand.

Competitive advantages also can be gained through other resources, including the size and nature of ore deposits, labor, investment capital, and technological capabilities. **The United States has 17 percent of the world's undeveloped copper resources—more than any other single country except Chile (see figure 1-3).** In particular, we have copper oxide deposits that will be amenable to low-cost in situ leaching when the technology becomes commercial. **On the other hand, our sulfide resources are relatively low in grade because of the age of our mines. This leads to higher production costs because of the expense in handling more material to produce an equivalent amount of copper.** For porphyry ore deposits (the most common), this difference in grade eventually will average out worldwide as other countries' copper industries mature.

Less-developed countries' (LDCs) main competitive advantage is in low wage rates. **While the domestic industry has the highest labor productivity among the world's copper-producing countries (see figure 1-9), labor costs are still a much larger share of our production costs than for most of our foreign competitors.**

<sup>21</sup>The domestic producer price is that set in direct producer-consumer contracts. The London Metal Exchange price is a spot market commodity price.

**Figure 1-8.-Average Net Operating Costs for Major Copper Producing Countries**



NOTE This chart compares average net operating costs to mine production. Net costs equal gross mining, milling, and smelting/refining charges, including transportation, minus byproduct credits. The average total cost is compared to only mine output because, while some countries (e.g., Peru) have very little smelting/refining capacity, those charges are attributed to the country in which the ore is mined.

SOURCE U.S. Bureau of Mines data

Developed countries, on the other hand, tend to be advantaged in attracting investment capital for new mines and technological innovation. The United States undermines this advantage when it contributes to international loans (e.g., through the World Bank) to develop copper resources abroad at interest rates lower than those that LDCs could obtain on the open market. Financing and interest rates will become more important to LDCs as their debt multiplies and they find debt financing more difficult to obtain.

Technology affects competitiveness both through the ability to research and develop innovations and to implement them given available worker skills. While the United States has some advantage over most of our foreign competitors in both aspects, this is largely negated by the rapidity of technology transfer in the world copper industry.

### What Contributed to the Domestic Industry's Current Competitive Position?

**A wide range of events—both domestic and international—shaped the current competitive status of the U.S. copper industry.** Market conditions in the U.S. copper industry began to worsen in 1980, when a labor strike idled a large portion of the industry. In 1981, anticipating strong demand growth, most operations resumed production at full capacity and output increased 30 percent. Instead, there was a global economic recession and demand growth was much lower than expected. oversupply conditions developed quickly. U.S. refined copper inventories increased 54 percent in 1981. The domestic producer price dropped 17 percent—the largest decline since 1975 (see figure 1-1 O). In 1982, domestic consumption declined 23 percent, inventories rose another 43 percent, and the price

**Table 1-1.—Changes in the U.S. Copper Industry: 1981.86**  
(1,000 metric tonnes)

Measure	1981		1986		Percent change
	Tonnes	Percent of total	Tonnes	Percent of total	
<b>Mine production:</b>					
United States . . . . .	1,538	230/0	1,147	17%	-250/0
World <sup>a</sup> . . . . .	6,489	100	6,629	100	2
<b>Primary smelter production:</b>					
United States . . . . .	1,317	21	908	13	-31
World <sup>a</sup> . . . . .	6,059	100	6,828	100	12
<b>Primary refinery production:</b>					
United States . . . . .	1,227	19	1,073	16	-13
World <sup>a</sup> . . . . .	6,327	100	6,348	100	<1
<b>Refined consumption:</b>					
United States . . . . .	2,030	27	2,122	27	5
World <sup>a</sup> . . . . .	7,252	100	7,672	100	6
<b>U.S. imports for consumption:</b>					
Ore and concentrate <sup>b</sup> . . . . .	39		4		-89
Refined . . . . .	331	16 <sup>c</sup>	502	24 <sup>c</sup>	51
Unmanufactured <sup>d</sup> . . . . .	438		598		36
<b>U.S. exports:</b>					
Ore and concentrate . . . . .	151		174		15
Refined . . . . .	24		12		-50
Unmanufactured . . . . .	NA		442		
U.S. net import reliance . . . . .	6		27		350
Producing copper mines . . . . .	58		61		5
Total mine/mill employment <sup>f</sup> . . . . .	30,600		10,154		-66
Operating primary smelters . . . . .	15		9 <sup>g</sup>		-40
Smelter/refinery employment <sup>f</sup> . . . . .	14,000		6,100		-56

<sup>a</sup>Market economy countries

<sup>b</sup>Copper content

<sup>c</sup>Percent of U.S. refined consumption

<sup>d</sup>Includes copper content of alloy scrap

<sup>e</sup>As a percent of apparent consumption; defined as imports - exports + adjustments for Government and industry stock changes

<sup>f</sup>Includes office workers

<sup>g</sup>One closed in January 1987

SOURCE: OTA from Bureau of Mines and World Bureau of Metal Statistics data

**Table 1.2.—Recent Government Acquisitions of Copper Capacity**

1967 . . . . .	Gecamines, Zaire	1000/0 nationalization
1969 . . . . .	Codelco, Chile	51 % takeover of major mines
1969 . . . . .	NCCM/RCM, Zambia <sup>a</sup>	51 % takeover of Zambia <b>capacity</b>
1971 . . . . .	Codelco, Chile	increase—51 0/0 to 1000/0
1974 . . . . .	Cerro de Pasco, Peru <sup>b</sup>	1000/0 nationalization
1977 . . . . .	Cerro Verde, Peru	Start-up, 1000/0 government
1979 . . . . .	ZCCM, Zambia <sup>c</sup>	Government holding increased to 60°/0
1980 . . . . .	La Caridad, Mexico	Start-up, 440/0 government

<sup>a</sup>Nchanga Consolidated COPPER Mines, Ltd (NCCM) and Roan Consolidated Copper Mines, Ltd (RCM).

<sup>b</sup>Cerro de Pasco renamed Centromin

<sup>c</sup>NCCM and RCM reorganized into ZCCM

SOURCE: Marian Radetski, State Mineral Enterprises (Washington, DC: Resources for the Future, 1985).

fell to an annual average of 73 cents/lb—a level at which only five or six U.S. mines could operate at a profit. As a result, the pace of mine shut-downs and worker layoffs, which had begun in late 1981, accelerated.

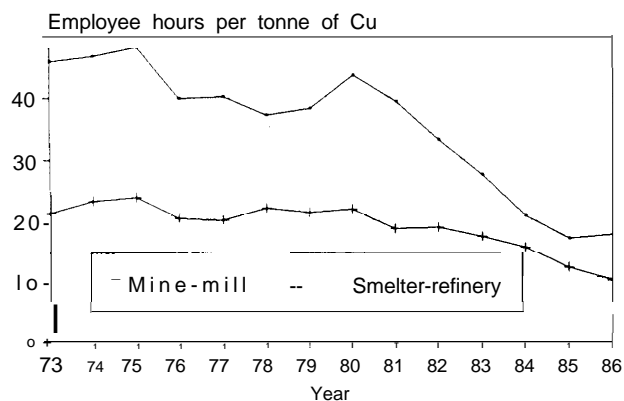
**In 1982, domestic mine production declined to its lowest level since the 1960s, and for the first time the United states was not the world's leading copper producer.** From March 1981 to January 1983, 28 domestic mines closed or cut



*Photo credit: John E. Robison*

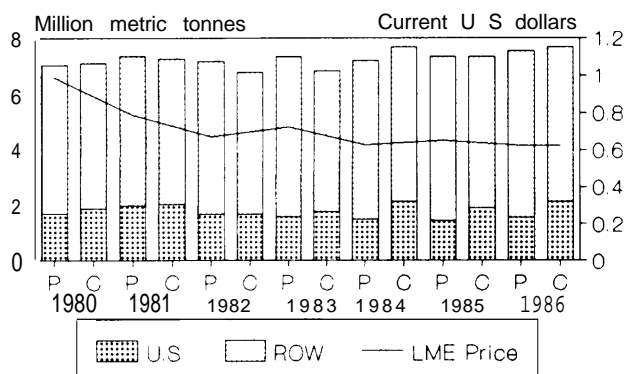
Open pit mining currently accounts for around 75 percent of domestic copper production. While this is a cost-effective extraction method, U.S. production costs are moderately high because domestic mines have to handle larger quantities of material due to our low ore grades.

**Figure 1-9.-Productivity in the U.S. Copper Industry: 1973-1986**



SOURCE U S Bureau of Mines

**Figure 1-10.-Average Price Compared with U.S. and Rest-of-World Refined Copper Production and Consumption**



London Metal Exchange Price  
"P" = production, "C" = consumption

SOURCE OTA from WBMS data.

back production, and total U.S. mine capacity utilization hovered around 65 percent. At the end of 1982, about 42 percent of the total copper work force had been laid off.

**While U.S. production declined sharply, foreign production increased (see figure 1-10).** In 1982, more than 60 percent of the copper-producing nations either increased or maintained their levels of production. Mine production outside North America increased almost 8 percent from 1981 to 1983. The intergovernmental Council of Copper Exporting Countries (CIPEC) con-

tinued to support its policy of maintaining production in spite of falling prices. The eight CIPEC members—Australia, Chile, Indonesia, Papua New Guinea, Peru, Yugoslavia, Zaire, and Zambia—accounted for 41 percent of world production in 1982, compared with 38 percent in 1981. Chile, alone, increased production 15 percent in 1982 and thereby became the world's leading copper producer. These additional supplies exacerbated the downward pressure on the already weak U.S. market prices. By December 1984, the price had fallen to \$0.55/lb, off 62 percent from its high of \$1.43/lb in February 1980.

Several factors contributed to this market picture. First, the strong dollar made U.S. exports less competitive and lowered the price of imported copper compared with its domestic counterpart. Second, the market share of foreign government-owned or controlled capacity increased. Governments—when they set production levels—often are concerned more with social goals such as maintaining employment and foreign exchange than with market conditions. Third, international financing institutions (in which the United States participates) assisted foreign capacity expansions. Finally, compliance with environmental regulations meant higher domestic operating costs (see box 1-B).

Most domestic companies met the challenges posed by these events head-on (see table 1-3). They made capital investments in new mine, mill, smelter, and refinery technology, and added solvent extraction-electrowinning (SX-EW) capacity (which has low capital, labor, and operating costs). They obtained direct cost reductions through wage cuts in the 1986 labor negotiations and rate cuts in power and transportation contracts. They cut back production at some facilities and closed high-cost operations. Finally, they restructured assets and shed debt through sales/purchases of copper or other types of business ventures.

**New technology that reduced costs through increased operating efficiency and productivity played a major role in helping the domestic industry regain its competitiveness.** For example, most operations have now installed automated controls at all stages of copper production. While

### Box I-B.—The Costs of Smelter Pollution Control

Domestic copper smelters must achieve 90 percent control of their sulfur oxide emissions. The gases from the smelter, roaster, and converter are collected, cleaned, and routed to a plant that converts the sulfur dioxide to sulfuric acid. This requires smelting and converting processes that result in relatively high concentrations of sulfur dioxide in their gaseous emissions (at least **4 percent for the smelter furnace**). The sulfuric acid can be sold or used at nearby mines for leaching copper from ores or waste dumps. In the absence of leaching operations, however, it usually is a "red ink" item because the main markets are nearer the Gulf Coast and the transportation cost is prohibitive.

Sulfur oxide emission controls resulted in the replacement of most reverberatory smelting furnaces in the United States with flash, continuous, or electric furnaces, because the reverberatory furnace gas has too low a sulfur oxide concentration for economical recovery. While this brought significant air quality improvements with related (but unquantifiable) health benefits, it also meant substantial capital expenditures for U.S. smelters, and increased operating costs due to the acid plant. Present levels of environmental control entail capital and operating costs of between 10 and 15 cents/lb of copper.<sup>1</sup> In addition to the increased cost, the U.S. industry has lost substantial smelting capacity. Of the 16 smelters operating in the United States in the late 1970s, **8** have closed permanently—most because the capital investment to meet regulations was unwarranted given current and anticipated market conditions.

In contrast, copper smelters in Canada, Chile, Mexico, Zaire, and Zambia—most of our major smelting competitors—achieve only about 1 to 35 percent control, or enough to produce the sulfuric acid needed at nearby leaching operations (see figure 1-1 1). Japanese smelters achieve 95 percent control as part of government policy to provide sulfuric acid for the Japanese chemical industry. Information regarding the costs of acid production in these countries is not available. However, it is clear that domestic air quality regulation combined with the location of acid markets puts U.S. producers at a competitive disadvantage.

<sup>1</sup>Everest Consulting, Air Pollution Requirements for Copper Smelters in the United States Compared to Chile, Peru, Mexico, Zaire, and Zambia, 1985.

the gains from such innovations will continue until the next generation of technologies comes along, the comparative advantages of such gains are largely negated over time by technology transfer. Most operations also added low-cost SX-EW capacity to reduce their average production costs.

### What Are The Likely Prospects For Future Competitiveness?

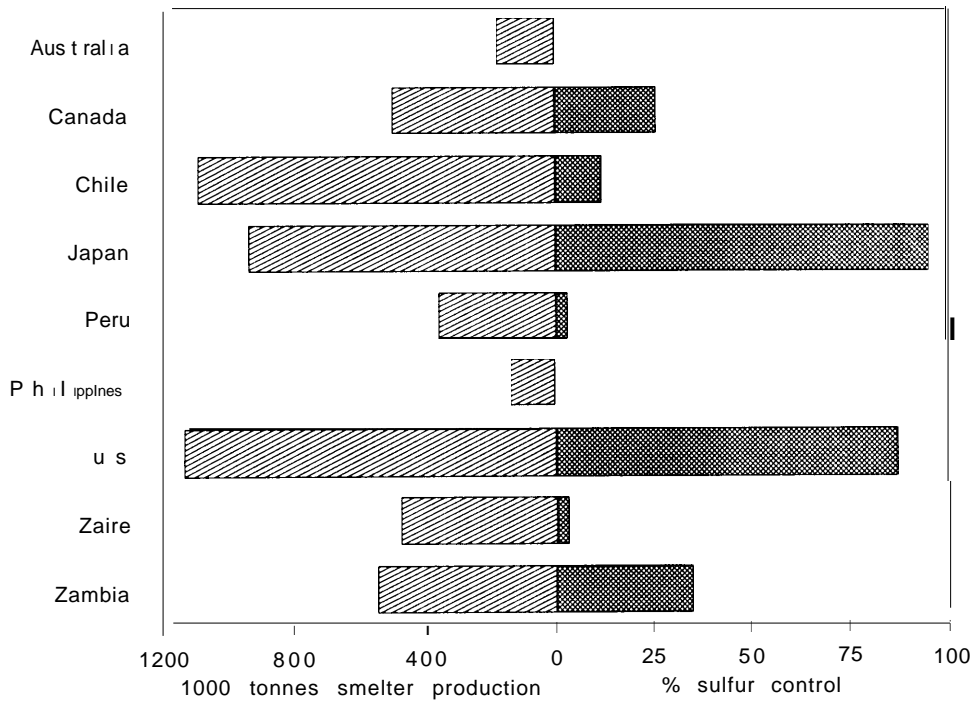
**The domestic industry's current production costs are low enough to ensure profitability into the early 1990s. Indeed, with the largely unforeseen rise in copper prices during 1987 (see box I-C), copper companies are enjoying excellent profits.** Though rapid price collapses followed similar price advances in 1973-74 and 1979-80, a rapid downturn is not expected during 1988-89 (barring another recession) because inventories currently are low. **But a gradual downward price trend is projected over the next**

**several years as world production grows more rapidly than consumption.**<sup>22</sup>

**World copper mine capacity is projected to increase significantly between 1988 and 1992.** If all planned mine expansions and new projects meet their anticipated production levels by the early 1990s, they will add around 1 million tonnes to annual output—15 percent of 1986 output. Other mines will cut back production or close entirely, however (e. g., the Tyrone mine in New Mexico will exhaust its sulfide reserves in the early 1990s). Future output from Zambia and Zaire are highly uncertain due to the need for significant capital investment in their mines and processing facilities, and because political unrest causes transportation problems. The widespread occurrence of AIDS in these countries also makes it more difficult for operations thereto attract skilled labor.

<sup>22</sup>Simon Strauss, "Copper: Prices Surged Unexpectedly," *Engineering & Mining Journal*, April 1988.

Figure 1-11.-Sulfur Dioxide Control



SOURCE: Duane Chapman, "The Economic Significance of Pollution Control and Worker Safety Cost for World Copper Trade," Cornell Agricultural Economics Staff Paper, Cornell University, Ithaca, New York, 1987



Photo credit: Manley-Prim Photography, Tucson, AZ

An electro-winning plant. Solvent extraction-electrowinning is one of the technologies that helped U.S. copper companies reduce their costs of production during the 1980s.

Table 1-3.—Strategies Adopted by U.S. Copper Companies in Response to Economic Conditions, 1980-87

Strategy	Amoco Minerals <sup>a</sup>	Arco/Anaconda <sup>b</sup>	Utilities Service <sup>c</sup>	Copper Range	Cyprus	Louisiana Land <sup>d</sup>	Inspiration <sup>e</sup>	Kennecott <sup>f</sup>	Magma	Montana Resources	Newmont <sup>g</sup>	Phelps Dodge
<b>Strategies to cut losses (or raise capital):</b>												
Sold copper properties (or shares)	X	X	X			X	X	X			X	X
Spun off properties to new company	X				X						X	X
Closed mine(s) for foreseeable future		X			X		X				X	
Closed mine(s) temporarily or cut production		X			X		X				X	
Closed smelter(s) permanently		X				X	X					X
Closed smelter temporarily							X					
Toll smelting only								X				
Closed refinery permanently		X				X						X
Closed refinery temporarily												X
Sold non-copper properties												X
Diversified												X
No longer in U.S. copper	X	X	X			X	X					
<b>Strategies to improve competitive position:</b>												
Bought developed copper properties				X	X					X		
Opened new mine(s)		X						X			X	
Expanded production at existing mine(s)	X											
Major mine modernization												
Other new mining technology												
Mill modernization		X										
Added SX-EW capacity												
Replaced smelter furnace												
Other smelter modernization												
Refinery modernization												
Built new refinery												
Improved balance between mining/processing						X						
Obtained State/local govt. assistance										X		
Renegotiated labor costs												
New labor contract												

<sup>a</sup>Copper properties spun off to Cyprus Minerals in 1980.  
<sup>b</sup>Closed all properties; Butte, Montana operations sold to Montana Resources in 1985.  
<sup>c</sup>Owned Duval; most properties sold or leased to Cyprus since 1985.  
<sup>d</sup>Sold to Echo Bay Co. before Northern Copper was formed to own/operate the White Pine mine.  
<sup>e</sup>Sold to Cyprus in June 1988.  
<sup>f</sup>Sold Ray Mines to Asarco in 1986 and Chino Mines to Phelps Dodge in 1986.  
<sup>g</sup>Spun off Magma (including Pinto Valley) as separate company in 1986, but retained a 15 percent interest.  
 Office of Assessment.



### Box I-C.—What Happened to the Price of Copper?<sup>1</sup>

Copper prices rose dramatically in the latter half of 1987—soaring to \$1 .45/lb by year's end—and hovered near \$1.00/lb in early 1988. In light of the low prices (**\$0.60** to \$0.64/lb) during 1983 to 1986 and the modest increases (to around \$0.70/lb) projected by analysts for 1987, this price boom was striking (see table 1-4).<sup>2</sup> It resulted from smaller consumer inventories, strong demand, moderate growth in production, and the weaker dollar, which in turn led to dwindling market inventories and increased market speculation.

**Consumer behavior.** In the early to mid-1980s, copper consumers adopted a policy of maintaining minimum inventories, largely in response to the general economic recession and the huge copper market stocks (17 percent of consumption in 1983). As consumers reduced their existing inventories to the new low levels, they masked the strength in copper demand and contributed to keeping the price low. In 1985-86, when industrial activity was improving and copper consumption was rising, the drawdown of inventories resulted in a decline in copper deliveries. The minimum inventory approach was a low-cost, low-risk policy as long as the price remained low and relatively stable, and stocks remained high. In 1987, when prices rose and stocks shrank (to below 10 percent of a year's deliveries), the potential costs and risks of minimum inventories increased. Consumers began building up their inventories, and consumption probably grew at a slightly lower rate than deliveries.

**Supply and demand.** Copper consumption and deliveries rebounded from the 1982-83 recession in 1984. Production increased much more gradually, however, and copper stocks dropped 32 percent during 1984. Although consumption probably increased further in 1985 and 1986, deliveries decreased because of consumer inventory reductions. Production in these years was more in line with deliveries, so producer and warehouse stocks were drawn down only about 12 percent in 1984 and 8 percent in 1986. The stocks, however, still remained above 10 percent of deliveries.

In 1987, when deliveries regained their 1984 levels, production was slow to react. It quickly became apparent that, contrary to widespread belief, significant capacity (idled during the early 1980s) was not waiting in the wings for improved market conditions. In the first quarter, stocks dropped 21 percent—to 9 percent of 1986 deliveries—and the price began to rise. This led to anticipation of a tighter market, and to increases in consumer inventories and speculative purchases. The trend continued in the second quarter, when stocks fell another 18 percent (to 7.6 percent of 1986 deliveries) and the price topped \$0.72/lb. Speculative buying picked up further, and warehouse levels actually rose slightly in the third quarter, while the price hit nearly \$0.85/lb. As the year waned, the discrepancy between the growth rates of supply and demand became apparent. At the same time, inventories dropped below 7 percent of a year's deliveries, and near-panic buying ensued. During the fourth quarter of 1987, inventories plummeted 44 percent and prices climbed to \$1 .45/lb.

**The value of the dollar.** Copper typically is priced in U.S. dollars. From 1980 to 1985, the U.S. dollar appreciated relative to other world currencies. When the dollar is high relative to the value of the currencies of consuming countries, they are able to purchase less copper for a given amount of money. This can depress demand. The effect can be offset to some extent by the fact that profits are measured in the local currency. Thus, for firms that export, the higher the dollar, the greater the local profits. After peaking in early 1985, the dollar devalued against the currencies of other developed countries. While this reduced foreign companies' profits, it also made copper cheaper. The shift in exchange rates, plus continued growth in worldwide industrial activity, stimulated demand.

<sup>1</sup>Unless otherwise noted, the information in this box is drawn from Simon Strauss, "Copper: Prices Surged Unexpectedly," *Engineering & Mining Journal*, April 1988.

<sup>2</sup>Figures given are London Metal Exchange prices in nominal \$U.S. per pound.

**Over the same period, world demand growth is expected to slow to around 1 to 1.5 percent annually as the huge debt held by LDCs inhibits their economic growth and thus their copper consumption.**

**If another recession were combined with sluggish demand and production increases, the price of copper would drop again—perhaps as low as 40 to 50 cents/lb (the estimated marginal cost of new large state-of-the-art operations opening**

Table 1.4.—Copper Markets: 1983-87

Date	Stocks <sup>a</sup> (1,000 mt)	LME price (U.S. \$/lb.)	Refined production (1,000 mt)	Refined deliveries (1,000 mt) <sup>c</sup>
Dec. 31, 1983	1,186.4	64.0	7,416.4	5,489.2
Dec. 31, 1984	802.4	59.9	7,274.8	6,076.0
Dec.31, 1985	701.6	64.0	7,390.9	5,687.8
Dec.31, 1986	645.9	60.4	7,522.8	5,578.1
Mar.31, 1987	514.5	68.2		
June30, 1987	423.9	72.5		
Sep.30, 1987	434.5	84.6		
Dec.31, 1987	243.3	145.4	NA	6,049.7

NA = not available.

<sup>a</sup>As reported by the American Bureau of Metal Statistics for Western world stocks at refinery warehouses and in the LME and COMEX warehouses. Reporting refineries account for an estimated 85 percent of production in market-economy countries.

<sup>b</sup>Primary and secondary.

<sup>c</sup>Deliveries to refineries as reported to the American Bureau of Metal Statistics. Data cover only about 85 percent of the Western world copper industry.

SOURCE: World Bureau of Metal Statistics; U.S. Bureau of Mines; Simon Strauss, "Copper: Prices Surged Unexpectedly," *Engineering & Mining Journal*, April 1988.

in the early 1990s). That price is below the current average domestic cost of production. Some of our foreign competitors, however, can operate profitably at that price. Others are likely to continue to produce regardless of demand in order to maintain employment or foreign exchange.

A price drop of this severity would produce roughly the same conditions for the domestic industry that existed during the early 1980s. Higher cost U.S. operations would have the same three choices: shut down, lose money, or find ways to cut costs further. Even with the cur-

rent high prices, many operations are still struggling to repay their debt from the last recession, and could not afford to lose much money. Moreover, because most companies already have taken advantage of available technological cost-saving measures, they will have fewer options without substantial R&D. Possible actions the government and/or the domestic producers might consider in order to prepare for and bridge such market conditions are discussed in the following sections.

## WHAT CAN THE FEDERAL GOVERNMENT DO TO IMPROVE THE PROSPECTS FOR COMPETITIVENESS?

Federal policies with potential impacts on the competitiveness of the domestic copper industry include those related to taxation, trade and foreign aid, defense, the environment, R&D, and general industrial development. The current effects of these policies on the copper industry vary. Some, such as present modest Federal investments in R&D and industrial incentives for education and training, are neutral or provide small benefits.

others, such as environmental regulation, have been very costly to the industry (although beneficial to society as a whole), but their primary impacts (smelter closure, or the capital cost of new smelters and acid plants) have run their course. The industry has made the capital expenditures necessary to comply with current reg-



Photo credit: Jenifer Rob/son

Copper mining generates large volumes of waste. More stringent disposal requirements (e.g., classifying mine waste as hazardous) would entail capital outlays and new mining practices that could lead to further mine closures.

ulations. Barring any further changes in environmental control requirements (e.g., more stringent air quality standards or classification of wastes as hazardous) that would require additional capital outlays, the present burden of compliance is in slightly higher operating costs compared with countries without similar requirements. This disadvantage could even out over the long term if pressure for environmental quality initiatives in LDCs mounted. On the other hand, more stringent environmental regulations could break the domestic industry.

**Decisions under various trade initiatives generally have gone against the primary copper industry.** As imports grew during the last decade, U.S. producers twice requested and were denied relief through tariffs, quotas, and orderly marketing agreements (bilateral agreements to restrict imports into the United States) under the Trade Act of 1974, Legislation introduced since 1984 would have required the Federal Government to negotiate with foreign producers to reduce their output during periods of low demand/price, and would have classified foreign subsidization of production during oversupply situations as an unfair trade practice. These proposals either did not pass Congress or were vetoed by President Reagan. The U.S.-Canada Free Trade Agreement (which has yet to be ratified; see box I-D) essentially ignores Canadian Government subsidization of copper producers by relegating the issue to a bilateral working group with a 7-year deadline.

**Tax policy, on the other hand, is generally beneficial to the industry.** For example, before the Tax Reform Act of 1986, the Congressional Budget Office estimated that the U.S. mining industry benefited more than any other sector from preferences designed to reduce its taxes.<sup>23</sup> The two most important tax provisions targeted specifically at the mining industry are depletion allowances and expensing of exploration and development costs.<sup>24</sup> Other pre-1986 tax benefits applicable to all industries (but now rescinded)

<sup>23</sup>U.S. Congress, congressional Budget Office, *Federal Support of U.S. Business* (Washington, DC: U.S. Government Printing Office, January 1984).

<sup>24</sup>Note that depletion allowances cover foreign production by U.S. firms.

included the accelerated cost-recovery system (ACRS), and the investment tax credit. These measures primarily benefited capital intensive activities, and their repeal will not unduly affect most of the industry's planned modernizations and low-capital cost SX-EW expansions.

**In examining these policies to determine what the Federal Government might do to help the copper industry remain competitive, three possible policy goals are apparent. The first is to refrain from interfering in the market; i.e., do nothing. The second goal is to protect the industry from the effects of a significant downturn in prices. The third goal is to promote industry investments in technologies and products that could lower costs and bolster market share in the event of such a downturn.**

### Option Set 1: Do Nothing

When OTA began this study, several copper industry executives expressed concern about the possible side-effects of government assistance. During their troubled times, they sought government intervention through trade measures to stem the rising tide of copper imports, through tax incentives to help finance plant modernizations, through relief from environmental regulations, even through direct government copper purchases. Yet **once their situation had turned around, the domestic industry was almost pleased that the government had refused aid. They had been left to make it on their own and, for the most part, had succeeded.** This does not mean, however, that they have stopped lobbying for a "level playing field" (e.g., in the U. S.-Canada Free Trade Agreement).

This strategy would maintain the status quo in all the policy areas listed above (i. e., it assumes no major changes in policy with the incoming administration). Except where current policies advantage or disadvantage the domestic industry compared with foreign competitors, this option set is policy neutral. Thus, tax policy would not reinstate investment incentives (even though they were available for pre-tax reform expansions and modernizations), trade relief would continue to be denied regardless of market conditions, environmental regulations would remain in place, and R&D would continue to be modest.

### Box I-D.—The U.S.-Canada Free Trade Agreement

The United States and Canada signed an accord in January 1988 that seeks to liberalize trade and investment between the two countries. This bilateral agreement would eliminate all tariffs on goods trade by 1998, reduce nontariff trade barriers, establish rules for bilateral investment, and create a dispute settlement mechanism.<sup>1</sup> To be enacted, the U.S.-Canada Free Trade Agreement (FTA) must yet be approved by the U.S. Congress and the Canadian Parliament.<sup>2</sup>

The FTA is opposed by several major copper producers, represented by the Non-Ferrous Metals Producers Committee (NFMPC),<sup>3</sup> because it phases out the tariff on imports of Canadian copper and it fails to prohibit some Canadian subsidization practices. These producers are concerned that Canadian copper mines and smelters are being modernized with below-market-rate capital made available through various national and provincial government assistance programs. They cite as an example the allotment of C\$84 million of government funds, from an acid rain program, for modernization and pollution control at Noranda's copper smelter at Rouyn, Quebec. There also have been suggestions that subsidies may be made available to reopen Noranda's Gaspé copper mine in Murdochville, Quebec (closed in April 1987 because of a fire), and to the Hudson Bay Mining and Smelting Co. copper smelter at Flin Flon, Manitoba. Even with such subsidies, Canadian smelters only recover an average of 25 percent of their SO<sub>2</sub>, compared with 90 percent recovery in the United States (see figure 1-11).

The accord does not actually sanction the subsidization programs, but leaves their legality up to a bilateral working group established to iron out the differences between U.S. and Canadian unfair trade law. Until the group finishes its work (up to 7 years), both countries would apply their own antidumping and countervailing duty laws to any disputes that may arise. For cases under these laws that are investigated in the interim, the FTA only comes into play after the U.S. International Trade Commission and Commerce Department (or their Canadian counterparts) have made their final determinations. Independent binational panels (instead of the national courts, as is now the case) would review contested determinations for their consistency with the laws of the country that made the ruling.<sup>4</sup>

<sup>1</sup> The accord also deals with services trade, business travel, energy and national security concerns, and some outstanding trade issues.

<sup>2</sup> The FTA was approved by the U.S. House of Representatives in August 1988.

<sup>3</sup> The NFMPC is a trade association whose members are Asarco, Phelps Dodge, and the Doe Run Co. (a lead producer based in St. Louis, MO). Their position on the FTA is outlined in the statement by Robert J. Muth, President, before the Mining and Natural Resources Subcommittee of the Interior and Insular Affairs Committee of the U.S. House of Representatives, Mar. 10, 1988. In addition to subsidies, the NFMPC is against the FTA because it weakens judicial review in unfair trade cases.

<sup>4</sup> In the United States, an unfair trade case can be concluded once the ITC and the Commerce Department have made their findings. Quite often, however, the determinations of these agencies are challenged before the U.S. Court of International Trade.

**Without major market changes in the interim, a severe price slump likely would have the same results as in the early to mid-1980s.** The highest cost producers would shut down, and others would cut back their conventional mine output and rely more on leaching and SX-EW production. Operations that have paid off their debt and accrued capital during the current high prices might buy facilities from firms that cannot survive periods of red ink.

**Technological innovation alone probably is insufficient to change this picture.** Even if advanced technologies were to bring further significant cost reductions to the domestic industry, rapid technology transfer and the insensitivity of many foreign producers to drops in price/demand

would mean at least temporary cutbacks in the domestic industry. **It will likely take a combination of technological innovation and a more stable and secure market share.**

### Option Set 2: Protect the Industry From World Market Changes

This group of options incorporates many initiatives promoted by the copper industry in the past, including protectionist measures, direct subsidization, and product support. **Protectionist measures under tax and trade policies** might encompass:

- tax breaks for copper consumers related to the difference in cost between foreign and

domestic copper to encourage them to “Buy American”;

- trade relief through tariffs, quotas, and orderly marketing agreements, etc. for copper imports from foreign government-subsidized capacity that contributes to oversupplies in world copper markets;
- pollution import tariffs for blister and refined products based on foreign producers’ degree of air quality control; and
- requiring U.S. representatives to the International Monetary Fund to ask for a ban on loans or other financial aid to countries that subsidize excess capacity or do not adjust production in response to market changes, or at least to vote against such loans.

**Direct government subsidization** could be introduced under defense or mineral policy. Congress could invoke the Defense Production Act (DPA) to support modernization of domestic copper capacity as part of preparedness policy (e.g., Title III loan guarantees to expedite production in the event of a national emergency). This option would be supported both by the fact that copper is a strategic commodity and by the long leadtime (typically 6 months to 3 years) needed to reopen shutdown mines or bring new mines on line. Military consumption of copper for ordnance alone quadrupled between 1965 and 1966, requiring the release of 550,000 tons from the National Defense Stockpile. DPA loans were then offered in 1967 to 1969 to stimulate domestic copper production.

A comprehensive minerals industry policy that would maintain a specified level of productive capacity at a cost commensurate with the value of the minerals to national security and the economy could be established under the Mining and Mineral Policy Act of 1970.

**Direct product support** might include domestic content requirements for imported products containing significant amounts of copper (e.g., automobiles); mandated use of domestic copper by government contractors (for instance, in Federal construction projects or defense contractor products); purchases of domestic copper to meet the National Defense Stockpile goal of 1 million short tons; and increased domestic copper content in coinage.

**This set of options, singly or in combination, would help the domestic copper industry maintain its competitive position in the face of adverse market conditions. However, when the underlying objective is to promote competitiveness by aiding industry adjustment to changing markets, protectionist policies tend to be counterproductive. They mask the market signals and eliminate an industry’s need to adjust.<sup>25</sup> They also may be costly to other sectors of the domestic economy (e.g., brass and wire mills and other copper consumers).**

Moreover, protectionist policies distort markets in ways that usually require increasing protection. For instance, Orderly Marketing Agreements (bilateral agreements to restrict imports into the United States) typically are used to give American firms time to adjust to new market situations. However, restricting imports from one country can stimulate increased production elsewhere. Also, limiting the volume of imports encourages foreign producers to move into higher value goods, or to alter the composition of the goods they produce to escape the quantitative limits on certain imports. Thus, such import restrictions simultaneously insulate American producers from incentives to adjust to foreign competition and provide powerful inducements to our competitors to adopt strategies that make them even more competitive.<sup>26</sup>

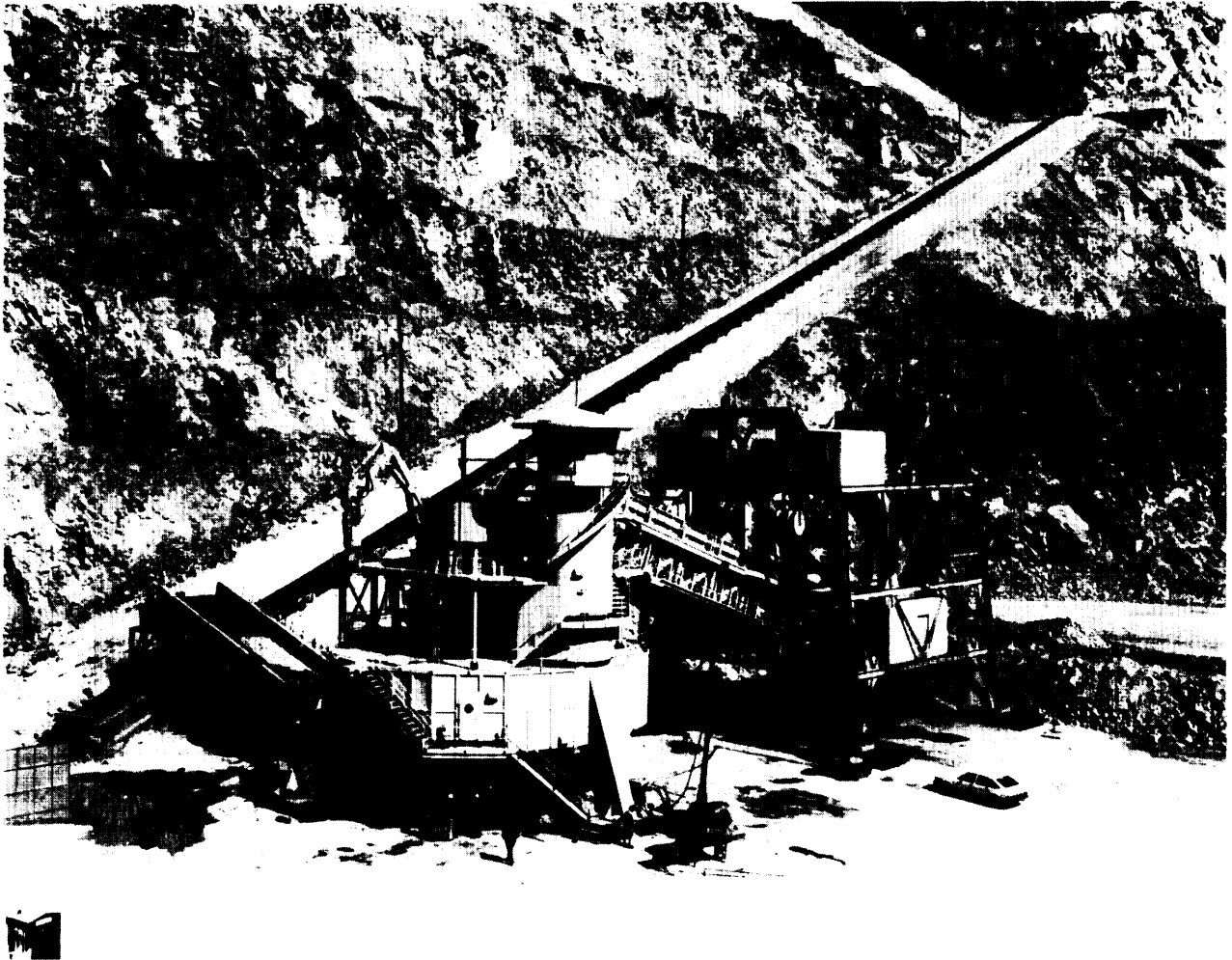
Protectionist policies, therefore, should be contemplated only when linked to an explicit and monitored plan for adjustment with a timetable. Alternatively, it may be more economically efficient to provide direct subsidies or exceptional tax arrangements to maintain domestic production during the market adjustment period.

### **Option Set 3: Promote Investments in Competitiveness**

**The alternative to protectionist policies are those that actively promote domestic competitiveness. Rather than insulating an industry from the impacts of market situations after they arise,**

<sup>25</sup>John Zysman and Laura Tyson (eds.) *American Industry in International Competition: Government Policies and Corporate Strategies* (Ithaca, NY: Cornell University Press, 1983).

<sup>26</sup>*Ibid.*



*Photo credit: Manley-Prim Photography, Tucson, AZ*

Conveyor systems coupled with in-pit ore crushers are particularly advantageous for U.S. mines because of our high truck haulage costs.

**such policies aim to anticipate market changes and promote government and private investments that will foster future competitiveness. Policy-makers thus need an understanding of the target industry's operations and the factors that contribute to its competitiveness (or lack thereof).**

**Because technology transfer is almost instantaneous in the copper industry, the first place to search for a technological advantage is in resources or aspects of production that are common in the United States but rare elsewhere.** For example, North America has copper oxide ore bodies that are particularly suitable for leaching and solvent extraction -electrowinning. The lowest cost copper (<30 cents/lb) currently is

produced using this technology in combination with mine waste dumps containing very low-grade resources, but for which the mining cost has already been incurred (see box I-E). However, research is underway on methods to leach ore in place (i. e., without ever having to mine it). When developed and proven in the field, in situ solution mining could provide a significant cost advantage for the U.S. industry. Labor-saving innovations also would benefit the domestic industry because our labor costs are so high. While these innovations could be copied elsewhere, the relative advantage would not be so great.

The U.S. industry also is at a disadvantage in materials handling: mines have to haul more ore

because of our lower ore grades, The combined energy, labor, and other costs make our transportation charges very high. Some mines are replacing trucks with conveyor systems coupled with in-pit ore crushing machines. While this technology is likely to be applied wherever in the world electricity is cheaper than diesel fuel, it benefits U.S. mines because of our high truck haulage costs. A more radical technological cost-saver might use artificial intelligence to develop some form of "driverless truck. "

**Policies that would promote development of these technologies include government investment in R&D and in education and training. Because most companies already have taken advantage of available technological innovations, radical rather than incremental research is needed.**

**There is no comprehensive Federal policy toward research and development** (whether for minerals or industry as a whole) .<sup>27</sup> Congress might authorize R&D as part of legislation in specific policy areas (e.g., as in the Mining and Mineral Policy Act of 1970), although actual appropriations may fall short of the authorization. R&D funding for minerals and materials also may be provided as part of an agency's general program responsibilities. The Bureau of Mines and Geological Survey (USGS) –both within the U.S. Department of the Interior–sponsor (and often carry out) most of the Federal R&D on copper production and related technologies.

The Bureau of Mines total R&D budget for FY 89 is expected to decrease by \$10 million to \$86 million. The proposed decrease was in applied research, which the Reagan Administration believes is the responsibility of private industry. Only about one-third of their present mining research budget goes to mining technology (figure 1-1 2a); of that, less than half could aid the competitiveness of the minerals industry (figure 1 -12b). The Geological Survey's total R&D budget for FY 89 is projected to be \$224 million, a decrease of \$12

<sup>27</sup>Although the United States spends more on R&D than any other country, it continues to lag behind some of its competitors in the share of gross national product devoted to civilian R&D. Japan spends nearly 3 percent of its GNP on R&D; the U. S. share is only slightly above 2.5 percent. see "R&D Scoreboard," *BusinessWeek*, June 22, 1987.

million from FY 88, About 75 percent of the USGS research budget is for geological and mineral resource surveys and mapping,<sup>28</sup>

Federal R&D support also could be introduced through tax incentives. Firms, however, could interpret a general R&D tax deduction or credit broadly to the detriment of Federal revenues. A provision targeted toward investments in commercial-scale (or nearly so) demonstration projects—the most expensive aspect of R&D—for promising technological innovations could be very effective,

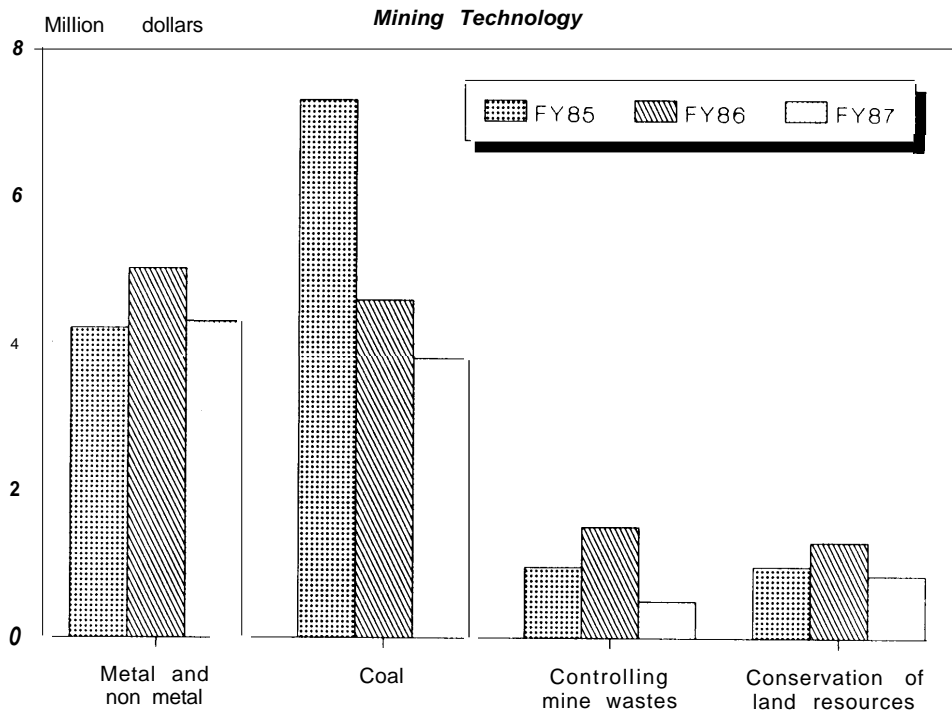
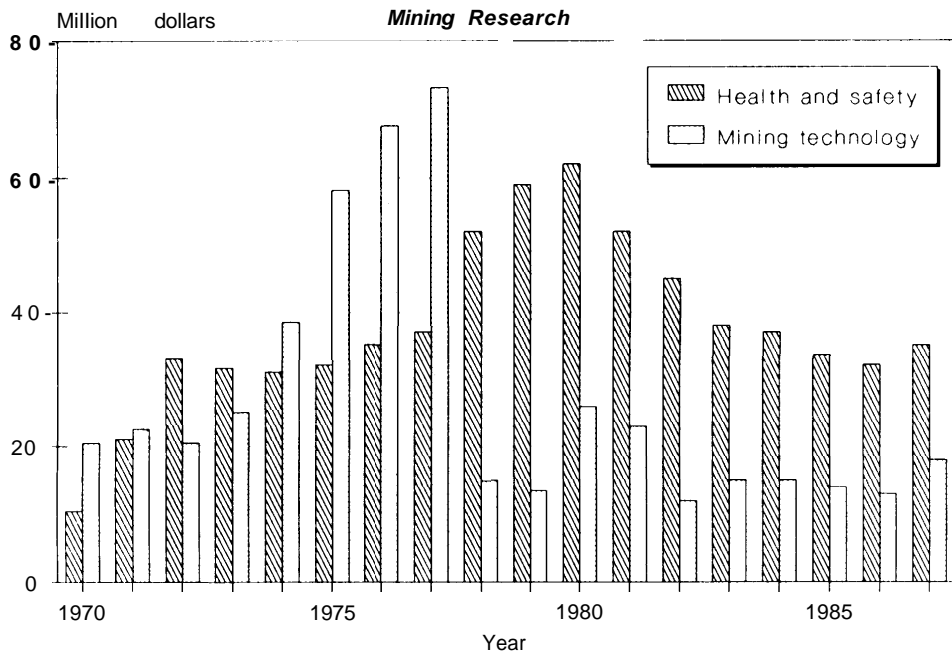
Some Federal (and private) R&D money goes to support research programs at universities, including the State mineral institutes and the Bureau of Mines mineral technology centers. The mineral institutes originally were administered by the Office of Surface Mining under the Surface Mining Control and Reclamation Act; responsibility subsequently was transferred to the Bureau of Mines. Almost every budget request since 1982 has proposed to abolish the institutes. Congress also has enacted special initiatives to provide seed money for research centers. One example is the new Center for Advanced Studies in Copper Research and Utilization at the University of Arizona, whose mandate focuses primarily on copper product applications (e.g., ceramic superconductors), but also includes process technologies (e.g., in situ solution mining).

**Research funding for universities not only provides a valuable source of technological innovation for the minerals industry, but also supports education and training for the next generation of industry employees.** While enrollment in mining and other engineering disciplines historically has been cyclical (and currently is low due to the poor economic performance of the minerals industry during the early 1980s),<sup>29</sup> evidence of Federal support for truly innovative **R&D** could at-

<sup>28</sup>Office of Management and Budget, *Budget of the United States Government, Fiscal Year 1989* (Washington, DC:U. S. Government Printing Office, 1988).

<sup>29</sup>In 1978, 3,117 undergraduate students were enrolled in 26 mining engineering programs in the United States. By 1987, the number of programs had dropped to 19, with additional closings and mergers expected. As a result, significant shortages of mining engineers are predicted at least through 1992. Eileen Ashworth, "Where Have All the Graduate\ Gone," *LANDMARC*, January/February, 1988.

**Figure I-12.-Trends in U.S. Bureau of Mines R&D**



SOURCE: U S. Department of the Interior, Bureau of Mines, *Technica/ Highlights: Mining Research 1987* (Washington, DC: U S. Government Printing Office, 1988)



tract high-quality students. Policies supportive of continuing education and training also would address high domestic labor costs by improving prod activity. JO

**The high cost of compliance with environmental regulations—especially air quality control requirements—also adversely affects domestic competitiveness.** Marketing the sulfuric acid byproduct of air pollution control is a major cost of compliance. Unless copper companies can use the acid at a nearby leaching operation, they lose money on it because the primary markets for sulfuric acid are on the Gulf Coast and transporting the acid there is not cost-effective. This has been less of a problem in the last several years because of the growth in leach production in the Southwest. If a sulfuric acid market imbalance were to reappear, the Federal Government might counteract it through options that could facilitate cheaper transportation to the Gulf Coast (e.g., amending the anti-trust laws to allow joint marketing or transportation agreements). This might create a sulfuric acid surplus in the Southeast, however. Promoting industrial development of sulfuric acid users near the smelters is another possibility, but could be limited by water availability.

**Research into more cost-effective means of pollution control also could help, but promoting control abroad would be more equitable.** A positive approach to accomplishing this is through International Monetary Fund loan incentives for environmental controls (e.g., variable interest rates based on the degree of control). More protectionist-oriented strategies would include

<sup>30</sup>An additional means of "leveling the playing field" for labor costs is to actively promote industrial development, and thus higher wages, in LDCs.

refusing to support international loans for projects that fail to achieve a certain level of control. As noted in box 1-D, the industry also is concerned about government subsidies for pollution control at Canadian smelters.

The strong dollar during the early to mid-1980s also adversely affected the domestic copper industry by favoring imports. This argues for Federal macroeconomic policies that support low interest rates and a devalued dollar, and thus promote exports.

Finally, domestic producers are sensitive to market signals, while many of their competitors ignore those signals in order to continue promoting social goals such as employment and foreign exchange. One alternative to the protectionist responses discussed previously is continued active support for the Copper Producer/Consumer Forum, and for international trading codes under the General Agreement on Tariffs and Trade (GATT) working group on trade problems affecting nonferrous metals. Both of these provide forums for voicing concerns to the LDCs about the market effects of their production strategies during recessionary conditions.<sup>31</sup>

**Also included in this set of options are policies that actively promote the U.S. copper industry and its products, whether through research on new products, through advertising, or through direct purchasing support (e.g., use of domestic materials in Federal buildings, and coinage).** While these might have a small impact on competitiveness, they can be important symbolically.

<sup>31</sup>The United States also might consider joining the Intergovernmental Council of Copper Exporting Countries (C IPEC), and use it as an educational forum. Participation in such consortia historically has been antithetical to U.S. political philosophy, however.

## WHAT CAN THE COPPER INDUSTRY DO TO MAINTAIN OR IMPROVE ITS COMPETITIVENESS?

Although they continue to seek government support to ensure future competitiveness, domestic copper companies are well aware that such support is not always (or even often) forthcoming. Thus, during the recent downswing, the in-

dustry made significant capital investments in new technology and took other actions to improve their own position. As noted previously, however, the next time the price drops it is likely to go lower and may stay lower longer. To be

competitive under those conditions, **domestic producers will need cost-saving technological innovations beyond those now being demonstrated (e.g., in situ solution mining) or a captured market. This will require investments in R&D now, as well as new ways of thinking about their product.**

R&D spending in the copper industry is low, averaging less than 1 percent of sales in 1986. This compares with an average for the whole metals and mining industry of almost 2 percent of sales, and a national industrial average of 3.5 percent of sales.<sup>32</sup> The copper industry considers mineral exploration to be their research; they rely on equipment vendors for process technology R&D and consumers for product research. **The Industrial and Mining Machinery sector also lags behind the national average in R&D expenditures**, however. Furthermore, the U.S. mining machinery industry consistently lost market share to foreign competitors throughout the early and mid-1980s, and now is operating with substantial excess capacity.<sup>33</sup> If this trend continues, their R&D expenditures can be expected to decline. At the same time, the growth of foreign equipment suppliers will mean that more R&D is likely to focus on foreign mining and processing problems.

**One option for increasing the level of R&D on process technology is for the industry to actively pursue cooperative research ventures involving producers, vendors, universities, and government agencies.** Anti-trust and patent concerns about such ventures were addressed in the National Cooperative Research Act of 1984 (Public Law 98-462). In 1987, a group of universities took the lead in forming the Mining and Excavation Research Institute (MERI) under the umbrella of the American Society of Mechanical Engineers. MERI's goal is to unite universities, industry, and government to provide coordination and leadership in long-range research. Industry members contribute \$5,000 annual dues and participate through the Industry Advisory Panel. Government funding is still being sought. In 1988 the American Mining Congress appointed a steering

committee to plan cooperative research.<sup>34</sup> A perennial concern in cooperative research is the continuity of funding from all parties once a project is underway.

**The domestic copper industry still faces competition for markets, both from imports and from other metals and materials (e.g., aluminum). Two basic options are available to offset further market losses—expand sales in current markets or develop new products and uses for copper and market them aggressively.**

The companies argue that marketing would be futile because they already are selling all the copper they produce. In the same breath, they complain about idle capacity. Simultaneously developing new markets and capturing a larger share of them could address both problems.

**One key to expanding sales is marketing based on product differentiation. Superior quality—including customer service—may command higher prices in the marketplace, making production costs less significant.** Although, copper traditionally has been considered a fungible commodity of uniform quality, different producers experience different rates of customer returns for breakage and other quality-related factors. Product differentiation based on quality is likely to become more important as specialty copper alloys and high-technology applications such as superconducting materials occupy an increasing share of the end-use market.

Similarly, **copper has properties that make it superior to the materials that often are substituted for it.** Copper industry associations have publicized copper's advantages in response to specific market threats (e.g., aluminum wiring in houses), **but neither individual companies nor the associations routinely advertise copper in order to reverse or prevent such substitutions.** In contrast, one of copper's major competitors—the aluminum industry—regularly advertises both

<sup>32</sup>"R&D Scoreboard," *Business Week*, June 22, 1987.

<sup>33</sup>ITA, *supra* note 16.

<sup>34</sup>Carl R. Peterson, "Tremendous Opportunities Exist for Major Technology Advances," *AMC Journal*, June 1988. Possible institutional frameworks for cooperative minerals industry R&D are discussed in U.S. Congress, Office of Technology Assessment, *Western Surface Mine Permitting and Reclamation* (Washington, DC: U.S. Government Printing Office, OTA-E-279), June 1986; see also Jenifer Robison, "Bridging the Research Gap," speech presented to the American Mining Congress Coal Convention, May 1986.

its product and its innovative research programs in the trade press.

**Product research also could forestall substitutions and expand markets.** Associations representing the primary copper industry publicize promising new applications, but do little direct research. Yet other metals in decline have found cooperative R&D with major consumers on new products very promising. The steel industry, for example, started a cooperative research program with U.S. auto makers to deal with the substitu-

tion of materials in, and foreign capture of markets for, steel parts in cars.

Finally, a "Buy American" campaign backed up with ads about the problems faced by the domestic copper industry could be very effective—especially if aimed toward the effects of imports on domestic capacity and employment. Foreign products and components not only threaten present domestic employment and market share, but also advance foreign manufacturing expertise and thus future foreign market share.

#### Box I-E. —Technological Innovation and R&D Needs

The last boom in technological innovation for copper production occurred in the first two decades of this century, when open pit mining, flotation concentration, and the reverberatory smelter were adapted to porphyry copper ores. Instead of great leaps forward, technological innovations of the last 65 years have largely consisted of adaptations of other types of technology to mining (e.g., computers, conveyor systems), plus incremental changes that allowed companies to exploit lower grade ores and continually reduce the costs of production. Economies of scale have been realized in all phases of copper production. Both machine and human productivity have increased dramatically.

Most copper producers have taken advantage of available technological advances. They have modernized their mining and milling equipment, installed new smelter furnaces, and updated their refineries (see table 1-3). Most operations also are now computerized, from truck dispatching, to underground remote control systems, to online monitoring and automatic controls in milling, smelting, and refining. The resulting cost savings are substantial. For instance, Asarco reduced its production cost at the Mission Mine 28 percent between 1981 and 1984, largely by modernizing the truck fleet and flotation cells and adding computerized systems.

The major recent innovation that contributed to the domestic industry's revival, however, is leaching/SX-EW. Phelps Dodge (PO) reduced its overall production cost at the Tyrone Mine as much as 11 cents/lb between 1980 and 1985 by adding leaching/SX-EW.<sup>1</sup> The process was so successful that PD expanded the Tyrone electrowinning plant, increasing its output to about 32,000 tonnes in 1986. Expansion to a total capacity of 50,000 tonnes/yr is scheduled for 1988-89.<sup>2</sup> To further benefit from this strategy, PD is adding two other SX-EW plants at Morenci and Chino. Other companies have made similar SX-EW capacity additions.

Some additional production cost savings may be achieved through innovations now undergoing site-specific demonstration and engineering. These include in-pit crushing and conveying, column flotation cells, and autogenous grinding. Still, major economic growth in the industry will require radical, rather than incremental, technological change. It also will require new technologies that compensate for inherent domestic disadvantages (e.g., low ore grades, high labor costs).<sup>3</sup> Possibilities are an underground continuous mining machine, in situ solution mining of virgin ore bodies (including sulfide and complex ores), alternative grinding methods, and a truly continuous smelting process.

<sup>1</sup> United Nations Industrial Development Organization (UNIDO), *Technological Alternatives for Copper, Lead, Zinc and Tin in Developing Countries*, report prepared for the First Consultation on the Non-ferrous Metals Industry, Budapest, Hungary, July 1987.

<sup>2</sup> "Phelps Dodge Has Something to Smile About," *Engineering and Mining Journal*, Aug. 1987.

<sup>3</sup> George S. Ansell, "Blending New Technology into an Established Industry," paper presented at the American Mining Congress Mining Convention, San Francisco, CA, Sept. 1985.

Part Two

# Industry and Market Structure

# CONTENTS

	<i>Page</i>
<b>The World Copper Market</b> .....	<b>39</b>
<b>Status of the U.S. Copper industry: 1980-86</b> .....	<b>40</b>
<b>The Struggle for Competitiveness</b> .....	41
<b>The Return to profitability</b> .....	42

## **Figure**

<i>Figure</i>	<i>Page</i>
<b>2-1. Mine Production in Major Copper-Producing Countries 1981-83</b> .....	<b>39</b>

Chapter 2

# **The Current Status of the World Copper Industry**

# The Current Status of the World Copper Industry

## THE WORLD COPPER MARKET

In 1981, the world copper industry appeared to be thriving. Production levels were strong and employment was high. The scarcity mentality of the 1970s had left many believing that copper, as a natural resource, would always be in short supply; that development in Third World countries would continue to drive demand growth; and that the market imbalance would keep prices strong. Projections of continuing demand growth, combined with high prices, led the world copper industry to focus more on increasing capacity and less on reducing production costs.

Instead of the anticipated growth and prosperity, the world copper industry received a severe jolt. The recession of 1982-83 stunted economic growth and development in most parts of the world. World demand for copper declined more than 6 percent during 1982. Copper consumption dropped in the United States—the primary market for domestic producers—even more sharply, falling 18 percent in 1982.

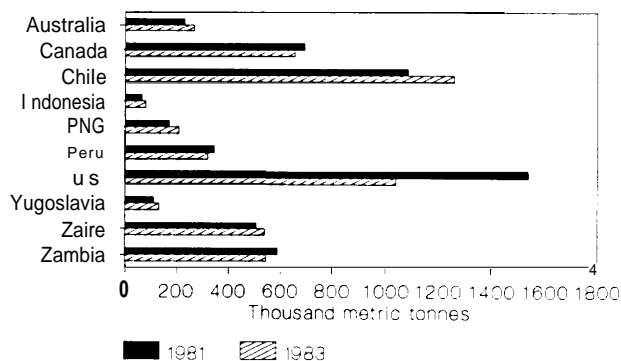
While demand waned, world copper production capacity continued to grow due to the ambitious expansion plans formulated during the late 1970s. The leadtime for a new or expanded copper operation is often several years or longer. When the mines initiated in the late 1970s finally came on line, they entered a market already plagued by mounting inventories. Subsequently, prices plummeted—falling over 50 percent from 1980 to 1984.

Despite high inventories and low prices, more than half of the copper-producing nations either increased or maintained production in 1982-83. Mine production outside North America increased almost 8 percent from 1981 to 1983. These were the countries with low production costs, or those whose output is more sensitive to

social goals (such as maintaining employment or foreign exchange) than to profits. The Intergovernmental Council of Copper Exporting Countries (CIPEC) continued to support its policy of maintaining production in spite of falling prices. The eight CIPEC members—Australia, Chile, Indonesia, Papua New Guinea, Peru, Yugoslavia, Zaire, and Zambia—accounted for 41 percent of world production in 1982, compared to 38 percent in 1981 (see fig. 2-1).<sup>1</sup> Chile alone increased its output 15 percent in 1982, becoming the world leader in copper mine production. In more profit-conscious countries—especially the United States and Canada—production dropped precipitously. In the United States, mine production decreased 26 percent in 1982; more than 28 mines closed, either temporarily or permanently, between March 1981 and January 1983.

<sup>1</sup>Mine capacity in Peru increased over this period, but actual production declined due to labor and other operational problems. By 1984, production had increased 3 percent over 1981; by 1985 it was 14 percent higher relative to 1981.

Figure 2-1.—Mine Production in Major Copper-Producing Countries, 1981-83



SOURCE U.S. Bureau of Mines data

## STATUS OF THE U.S. COPPER INDUSTRY: 1980-86

Due to the continued oversupply, the world copper market remained depressed for several years after signs of recovery had appeared in other economic sectors. These conditions hit the domestic copper industry especially hard. In 1981, U.S. copper mine production had exceeded 1.5 million tonnes,<sup>2</sup> but over the next 2 years domestic output fell nearly one-third to just over 1 million tonnes, and remained below 1.2 million tonnes through 1987. Output from domestic copper smelters and refineries also declined after 1980, in part in response to market conditions, but also due to the closure of older smelters that would be too expensive to upgrade to comply with air quality regulations. U.S. primary and secondary copper smelter production fell from a strong 1981 level of nearly 1.4 million tonnes to about 1 million tonnes in 1983, and then increased to 1.2 million tonnes by 1986.<sup>3</sup> While the United States remained the world's leading supplier of refined copper, domestic production in 1986 (1.6 million tonnes) was more than 20 percent lower than the peak level of 1981.

**The domestic employment impacts of the changing market structure have been severe.** In 1979, the U.S. copper industry employed over 44,000 people in mines, mills, smelters, and refineries, and over **46,000** at fabricators. By the end of 1983, direct employment in the domestic industry that mines and processes copper had fallen by 41 percent. The impact on regional economies extends beyond the jobs lost in the mining and minerals processing industry. In Arizona, for example, the Bureau of Mines estimates that for each 10 jobs in the primary metals industry, an additional 14 jobs are created in the businesses that supply goods and services to the industry and their employees (e. g., equipment suppliers and retail establishments).<sup>4</sup>

<sup>2</sup>All figures in this report are in metric tonnes unless stated otherwise. One metric tonne = 0.907 short tons = 2,204 pounds.

<sup>3</sup>Primary smelters process new copper, mostly in the form of concentrates. Secondary smelters process copper scrap.

<sup>4</sup>The figures given include mining, smelting, and refining of all primary metals, including copper, gold, silver, molybdenum, and lead. However, because the copper mining and processing industry represented 74 percent of the total value of Arizona minerals production in 1986, the impacts are considered representative of copper.

**U.S. copper producers' struggle to survive in a more competitive market has brought about an emphasis on more efficient, less labor-intensive technologies.** While improved productivity has been an important step in maintaining a viable domestic copper industry, many jobs have been eliminated as a result. For example, in 1980 the Bingham Canyon mine in Utah employed 7,000 workers to produce around 182,000 tonnes of copper. These operations made Kennecott, now BP Minerals America, Utah's largest private employers Bingham closed in 1985 due to market conditions and pending management decisions about modernization. Employment fell to 240 maintenance and security personnel. Subsequently, around \$400 million was invested in modernization of the mine, mill, and ancillary facilities. When Bingham Canyon reopened in 1987, employment, including construction workers for modernization efforts, was only 2,371. Full production of 200,000 tonnes is expected in mid-1988 with 1,800 employees. This represents a 75 percent reduction in labor requirements as a result of the more efficient operations.

The increased competition for markets has focused attention on copper supply levels and production costs. **The domestic copper industry has several cost-related disadvantages to overcome in order to be competitive in the world market (see ch. 9).** These include low ore grades, high labor costs, and stringent environmental and health and safety regulations. The first two have affected domestic production costs throughout the history of the industry, but have become more important over the last 10 years as a larger share of world copper capacity shifted to less developed countries.

**The nature of U.S. resources places the domestic industry at an immediate disadvantage.** The average ore grade of domestic copper reserves is about 0.62 percent copper—more than 30 percent lower than the world average. This means that U.S. operations must mine and mill about 30 percent more ore than the average com-

<sup>5</sup>Personal communication to OTA from Frank Fisher of BP Minerals America.



petitor in order to recover the same amount of copper (see ch. 5).

While highly productive, U.S. workers are paid wages four or five times higher than those at most foreign operations. **Despite our higher productivity, the net result of the lower ore grades and higher wages is that labor costs per pound of copper in the United States are well above the world average.**

## THE STRUGGLE FOR COMPETITIVENESS

For the most part, **the domestic industry met the challenge to compete in the world copper marketplace head-on. They developed and implemented ambitious strategies aimed at cost reductions at all stages of copper production.** In general, the overall strategies formulated by most domestic producers contained the same major components: 1 ) reduced labor and other costs; 2) capital investment in more efficient equipment and technologies, particularly expansion of leaching and SX-EW facilities; 3) revised mining strategies; and 4) corporate and debt restructuring (see ch. 10).

The cost of labor to the U.S. copper mining industry has dropped considerably in the last few years as a result of wage and benefit concessions and productivity gains. Workers accepted 20 to 30 percent reductions in the 1986 contract negotiations. In return, they receive incentives for productivity increases. Bonuses tied to increases in copper prices also assure labor of a share of the profits when market conditions are good.<sup>6</sup> Other efforts to reduce labor and administration costs have included redefining jobs at all levels to reduce overhead and increase staff flexibility; eliminating several corporate levels to reduce personnel requirements and improve communications; and relocating executive and administrative offices closer to company operations to cut office expenses and travel. Non-labor costs such

**Another important cost component for domestic producers is compliance with environmental and health and safety regulations. A**

1985 industry estimate of the cost to U.S. copper producers for compliance with these regulations was around 10 to 15 cents/lb. While there is some evidence of growing consciousness in developing countries of the environmental impacts of mining and smelting, the degree of pollution control in these areas is much lower (see ch. 8).

as transportation and energy charges also have been reduced through the renegotiation of contracts.

The expanded use of solution mining, or leaching, methods in the domestic copper industry also has played a crucial role in the industry's renewed competitiveness. Solution mining offers a means by which the vast amount of low-grade ore in mine waste dumps can be processed economically (see ch. 6). The costs of mining the waste ore have already been taken from the books. As a result, producing copper using leaching, followed by solvent extraction and electrowinning, costs only about 30 cents/lb.

In-pit conveyors and automated truck dispatching systems also have improved productivity and decreased costs. Mill efficiency has been improved through computerized onstream analysis and flow control. Other technological milling improvements include new materials for ball mill linings, larger tumbling mills and flotation cells, using chunks of ore rather than steel balls in tumbling mills, and column cells. The Asarco Mission Mine complex reduced their cash cost of producing 1 pound of copper in concentrates about 28 percent between 1981 and 1984—largely by modernizing their truck fleet and flotation cells. Smelter and refinery efficiencies have been improved primarily through automated controls and computer monitoring, and reduced energy consumption.

Closure of many high-cost operations was necessary to achieve the lower average cost of domestic production. In addition, many companies

<sup>6</sup>As a result of the sudden rise in copper prices in 1987, 4,100 of the **9,500** copper workers in Arizona received bonuses totaling more than \$10.4 million in January 1988.

revised their mining plans by raising the ore cut-off grade, lowering the waste-ore stripping ratio, steepening pit slopes, or closing low-grade sections of underground mines. These changes im-

proved productivity and further reduced costs. At some mines, however, these improvements may reduce long-term capacity.

## 1987—THE RETURN TO PROFITABILITY

When copper prices soared to over \$1/lb in 1987, with spot prices reaching \$1.50/lb near the end of the year, the domestic copper industry was ready to reap the benefits. Cost-cutting measures implemented in the industry had brought domestic average copper production costs down to \$0.55/lb in 1986 as compared with \$0.79/lb in 1981. When combined with the increase in prices, this meant the return to profitability for an industry that had suffered enormous losses earlier in the decade.

Of the six major U.S. copper-producing companies, four operated throughout 1987 and all four reported net profits, ranging from \$279 million at Asarco to \$26 million at Cyprus. Kennecott and Magma are expected to report net profits for

1988, when they resume full production after major modernization efforts.

**While the domestic industry is enjoying its current prosperity, it is not entirely sanguine about the future.** The industry is still contracting, as evidenced by the sale of Inspiration Consolidated Copper Company's domestic operations to Cyprus Minerals in 1988. Moreover, **most copper company executives anticipate that the conditions that prevailed during the first half of this decade will be repeated during the next recession. Because most companies have already taken advantage of available cost-reducing technological innovations, they are concerned that they will have few options for further cost reductions without major technological breakthroughs.**

**Chapter 3**

# **The Business Structure of the Copper Industry**

# CONTENTS

	<i>Page</i>
<b>Investment Risk</b> .....	<b>45</b>
<b>Ownership of Capacity</b> .....	<b>48</b>
<b>The Changing Ownership of Domestic Capacity</b> .....	<b>48</b>
<b>The Expansion of State Mining Enterprises</b> .....	<b>50</b>
<b>International Financing and Subsidization</b> .....	<b>52</b>
<b>Price Structure</b> .....	<b>54</b>
<b>The LME and COMEX</b> .....	<b>54</b>
<b>Direct Producer-Customer Contracts</b> .....	<b>56</b>
The Role of Inventories .....	<b>57</b>
Near-Term Price Determinants .....	<b>57</b>
Long-Term Price Determinants .....	<b>58</b>
The Effects of Price Instability .....	<b>58</b>

## Boxes

<b>Box</b>	<i>Page</i>
3-A. The Cost of Greenfields Has Grown Tremendously .....	47
3-B. Phelps Dodge and the Consolidation of Ownership .....	49
3-C. increased Government Control in the World Copper Industry .....	52
3-D. intermediaries in the Copper Market .....	56
3-E. The Volatility of Copper Prices and Demand .....	60

## Figures

<i>Figure</i>	<i>Page</i>
3-1. Copper Market and Price Structure .....	55
3-2. Most Copper Trade Occurs at the Refined Stage: .....	56
3-3. London Copper Price .....	59
3-4. GNP Compared to Copper Price .....	59

## Tables

<i>Table</i>	<i>Page</i>
3-1. Government Ownership in the Copper Industry, 1981 .....	51
3-2. Government Acquisitions of Copper Capacity .....	53
3-3. Major Copper Price Quotations .....	56

# The Business Structure of the Copper Industry

---

The structure of the world copper industry has changed significantly during the last 25 years. Rapid growth in world copper demand began in the industrialized countries following World War II, and then shifted to the less developed countries. This led to the construction of significant new copper production capacity. Initially this capacity was owned and operated by the same corporations that had controlled the industry for most of this century. Gradually, however, changes in investment risks, in the development philosophies of third world countries, in the diversification strategies of multinational corporations, and in the way copper is bought and sold on world markets, changed the picture substantially. Today, instead of several multinationals developing copper properties and selling their products under contract prices, there are numerous producers—many of them government-owned or

controlled. In addition, since the mid- to late 1970s, the New York and London commodity exchanges have played a more important role in setting copper prices.

This chapter reviews the major factors that have influenced the structure of the world copper industry in recent years. It begins with a discussion of the investment risks in a copper venture. It then outlines trends in domestic and world copper capacity ownership since 1960, and analyzes the role of international financial institutions in capacity development. The chapter ends with a description of pricing, including how prices are set, the factors that may affect price over the short- and long-term, and the impacts of unstable prices on producers. The following chapter describes the market structure of the copper industry in terms of supply and demand trends.

## INVESTMENT RISK

**Copper mining and processing are characterized by large, high risk capital investments.** Because many mining operations are located in remote areas, significant infrastructure costs often are incurred as well. Thus, private investors in the mining industry require a greater return on invested capital than those investing in retail or manufacturing ventures of comparable size.

**The potential risks include negative exploration results, market changes during or after mine development, government nationalization, and disruptions from political or natural causes.** First, copper is a relatively scarce element.<sup>1</sup> The size and shape of a deposit must be estimated from numerous data sets with varying degrees of certainty. A company will invest perhaps tens of

millions of dollars and 5 years or more in exploration and feasibility studies.<sup>2</sup> Not only must a deposit contain copper, but either the copper or its by- or co-product minerals (e. g., gold, silver, cobalt, molybdenum) need to be of sufficient grade, quantity, etc. that extraction and processing are economically feasible, given current and anticipated conditions in the copper market.

Second, development of a new mine or expansion of existing facilities requires a long leadtime—a year or more for expansions and an average of 2 to 5 years for new operations. During this period, economic conditions can change drastically and may alter profitability. The uncertainty in predicting the economic feasibility of a project increases with the leadtime, and so does the risk.

<sup>1</sup> The Bureau of Mines estimates the average grade of demonstrated lead and zinc resources to be 2.22 and 5.10 percent, respectively, while the average grade of minable world copper resources is less than 1 percent; see ch. 5.

<sup>2</sup> Exploration and development are discussed in detail in ch. 6.



Photo credit: John E. Robison

Copper mining and processing require large, high-risk capital investments.

The political environment of a copper operation also may add risk. Corporate officials can choose a site for a manufacturing plant, but can only mine copper where it is found. More than one-half of the Non-Socialist World's (NSW)<sup>3</sup> copper resources are located in the developing nations of Latin America and Africa. Many of these nations are striving to improve their standard of living through economic development and political autonomy. Strict government control often accompanies this effort and turmoil is not uncommon.

<sup>3</sup>The Non-Socialist World (NSW) refers to all copper producing and consuming market economy countries. This includes Yugoslavia, but excludes Albania, Bulgaria, Czechoslovakia, Cuba, Democratic Republic of Germany, Hungary, Poland, Romania, and the USSR. China is also excluded from consumption and production figures, but is included in trade figures because of the significant amount of copper imported into China from NSW countries in recent years.

During the 1960s and 1970s, there was a wave of government nationalization of foreign-owned mining enterprises. In some cases, compensation to foreign investors was small or nonexistent. For example, when the Chilean government first expropriated the country's four largest copper mines, compensation was offered for only one mine. Later, when the military junta led by General Pinochet took over the country, some compensation for all properties was negotiated with the previous owners. Because of this risk, private investment in foreign mining operations declined until recently when developing countries, burdened with heavy debts, began offering inducements to foreign investors to bring in needed capital (see discussion of government ownership, below).

Mines and mineral processing facilities located in politically unstable areas (especially those experiencing armed conflicts) have additional risks.

These operations sometimes have a strong impact on regional and national economies (i.e., they are major employers or represent significant foreign exchange earnings), making them targets for aggressive actions. Threats of labor shortages, damage to equipment and machinery, disruption of energy supplies, and interruption of transportation services loom in these situations.

Supplies do not actually have to be interrupted to have significant economic impacts on U.S. mineral markets, however. For example, a rebel invasion of Zaire's mining country in 1978 led to fears of a cobalt shortage that stimulated panic buying. Prices soared and domestic users turned to cheaper substitutes and recycling where possible. However, mining and processing facilities were closed only briefly, and cobalt production in Zaire and Zambia actually increased 43 percent in 1978 and 12 percent in 1979.<sup>4</sup>

Copper resources are often located in remote regions, so adverse physical conditions are not unusual. Extreme weather may interrupt production (e.g., at the Andean mines of Chile and Peru), or the altitude, humidity, or other conditions may require extensive testing and adaptation of machinery and equipment.

In addition to being risky, copper mining operations are capital intensive (see box 3-A). More and more of the world's high grade resources are being depleted, making it necessary to mine and process lower grade ores. Capital investment is a function of the gross ore tonnage handled rather than the net amount of copper processed. The need to handle more ore has led to greater mechanization of operations in order to reduce operating costs. This has increased the initial cash outlay for labor, equipment, and services during the start-up time, as well as the cost of the money used to pay these expenses (i.e., the cost of interest on borrowed funds and/or the opportunity cost of equity funding.)

Mining and smelting also have environmental impacts (see ch. 8). In the United States, considerable capital investment as well as increased operating costs are incurred to meet strict envi-

<sup>4</sup>U.S. Congress, Office of Technology Assessment, *Strategic Materials: Technologies To Reduce U.S. Import Vulnerability* (Washington, DC: U.S. Government Printing Office, OTA-ITE-248) May 1985.

### Box 3-A.—The Cost of Greenfields Has Grown Tremendously

The cost of opening a greenfield (new) mining operation has skyrocketed. In the United States, declining ore grades and rigid environmental regulation have compounded this cost. For example, in 1953, the Silver Bell mine/mill in Arizona opened with an initial capacity of 18,000 tonnes of copper per year at a capital cost of \$18 million, or \$1,000 per ton of capacity.<sup>1</sup> In comparison, in 1982, the Copper Flat mine in New Mexico required an initial investment of \$103 million for 18,000 tonnes per year. This represented \$5,720 per ton of capacity—470 percent more than the Silver Bell operation.<sup>2</sup>

One result of the tremendous surge in the cost of greenfield projects has been an increase in the incremental expansion of existing capacity. In the 30 years from 1950 to 1980, when demand was growing rapidly, around 20 new copper mines were opened in the United States, while perhaps five mines expanded production substantially. With slightly lower demand growth, only two or three new conventional mines may open in the United States between 1980 and 2000, while most operating mines plan to expand their conventional mine capacity or add leaching capacity during that period.

<sup>1</sup> Cost figures in box 3-A are nominal U.S. dollars.

<sup>2</sup>Simon Strauss, *Trouble in the Third Kingdom* (London: Mining Journal Books Ltd., 1986).

ronmental regulations. Even in less developed countries, environmental conditions are becoming more important. In 1986, Chilean smelter workers threatened to disrupt production due to concerns about the health effects of sulfur and arsenic emissions.<sup>5</sup>

Mines in remote areas typically require large investments in infrastructure. In addition to housing, roads, and utilities, community facilities such as schools, hospitals, and recreation centers also must be provided. Government subsidization of infrastructure is sometimes available; otherwise, the mining company must absorb the entire cost. Because the cost is incurred before production begins, this increases capital investment.

<sup>5</sup>JaniceL.W. Jolly and Daniel Edelstein, "Copper," preprint from 1986 *Bureau of Mines Minerals Yearbook* (Washington, DC: U.S. Department of the Interior, Bureau of Mines, 1987).

## OWNERSHIP OF CAPACITY<sup>6</sup>

Because of the need for large scale operations and the enormous capital investment required, ownership and control of most of the world's copper mining and processing capacity is held by large multinational corporations and State mining enterprises. Governments and multinationals are better able to acquire the financing for copper mining ventures and to absorb the risks.

Prior to the 1960s, multinationals controlled most of the world's copper production capacity. In 1947, four major private mining firms held an estimated 60 percent of world copper output.<sup>7</sup> This share had dropped to 47 percent in 1956 and, by 1974, the four largest mining firms held a majority ownership interest in less than 19 percent of NSW copper output.<sup>8</sup>

In general, the last 25 years has seen a broad diversification in ownership of capacity, followed by some contraction. Diversification moves included more countries producing copper (recent market entrants include Papua New Guinea and Indonesia), increased government participation in mining (especially in Africa and South America), the acquisition and subsequent sale of copper operations by oil companies (primarily in North America), and the increased importance of independent (non-integrated) mining and smelting companies (e.g., the rise of the Japanese smelting industry; see ch. 4). This was followed in the last few years by the consolidation of many government-influenced enterprises, oil company divestitures, and increased integration.

### The Changing Ownership of Domestic Capacity

In the mid-to late-1800s, gold and silver discoveries could make or break an individual prospector, but copper deposits typically were financed

first, by conglomerates "back East" that needed copper to feed the industrial revolution, and then by companies that already owned established mining properties. Thus, exploitation of the copper deposits on the Keweenaw Peninsula of Michigan<sup>9</sup> was financed by companies in Boston. "Firms that had their start in Butte, Montana (e.g., Amalgamated Copper Co., later to become Anaconda Minerals) provided capital to develop deposits in Arizona (e.g., the earliest Miami mines and the United Verde mine)."<sup>11</sup>

Two trends fostered the initial concentration of ownership in the copper industry. First, established fabricators in the East were searching for new supplies as the U.S. economy advanced and people moved West. Thus Phelps, Dodge & Company (PD), a New York mercantile outfit that had entered the copper and brass fabricating business in 1845, purchased its first copper claim (the Atlanta) in Bisbee, Arizona in 1881 to secure its supply of raw materials. Today, PD is the largest U.S. copper producer, but is no longer in the fabricating business (see box 3-B).<sup>12</sup>

Second, with development of the mining industry, the amount of capital needed to finance a new venture increased rapidly. For instance, Phelps, Dodge and Company purchased the Atlanta claim for \$40,000, and then spent 3 years of development work and an additional \$95,000 just to find the main ore body.<sup>13</sup> Although initial capital investments often were sufficient to locate a deposit, or even begin production, additional financing usually was needed to maintain the competitive status of projects as the ore type and grade changed over time (e.g., the Douglas smelter mentioned in box 3-B).

Other investments were required because the state of technological development was rudimentary when a mine opened. In Globe, Arizona, for

<sup>6</sup>The corporate structure of the world copper industry, including the principal players, is discussed in ch. 9.

<sup>7</sup>Outside of the USSR.

<sup>8</sup>Raymond F. Mikesell, *The World Copper Industry: Structure and Economic Analysis* (Baltimore, MD: The Johns Hopkins Press, 1979), p. 28.

<sup>9</sup>The first major mines in the United States; see ch. 6.

<sup>10</sup>Donald Chaput, *The Cliff: America's First Great Copper Mine* (Kalamazoo, MI: Sequoia Press, 1971).

<sup>11</sup>Table 6-3 in ch. 6 shows a detailed history of U.S. mine development, including initial and subsequent ownership.

<sup>12</sup>Lynn R. Bailey, *Bisbee: Queen of the Copper Camps* (Tucson, AZ: Westernlore Press, 1983).

<sup>13</sup>*Ibid.*



### Box 3-B.—Phelps Dodge and the Consolidation of Ownership

Phelps Dodge began their first copper mining venture in Bisbee, Arizona in 1881 to feed their brass mills back East. At that time, they had numerous competitors in Bisbee. These included small operators with limited financial backing, as well as early mining conglomerates such as the Calumet & Arizona Mining Co., which was formed to operate the Irish Mag mine in Bisbee and later bought the New Cornelia claim in Ajo. PD began to consolidate their holdings in Bisbee within a couple of years, first with the purchase of the Copper Queen mine, whose underground workings had broken through into the Atlanta claim. The Copper Queen continued to produce until 1975. Over the next 20 years, PD bought several other claims and mines in Bisbee to improve the efficiency of their mine plans and ore processing. Their increased mine production, plus changes in the ore, led to construction of the Douglas smelter in 1904 (which closed in 1987), the largest and most modern smelter of its time.

In 1895 to 1896, PD also expanded into other parts of Arizona and Mexico by purchasing the Detroit Copper Co. and its properties in Clifton/Morenci and the Guggenheim interests near Nacozari, Mexico. In 1910, they acquired the claims in Tyrone, New Mexico. All of these areas are still producing copper, although PD is no longer involved in Nacozari. During the 1920s, PD added the Old Dominion mine in Globe, Arizona.

In 1929, PD went public. This provided them with an infusion of capital just before other companies began suffering huge losses due to the depression. During the 1930s, they purchased the Arizona Copper Company (the remaining claims in the Clifton area), and the Calumet & Arizona Company. PD's ownership status then remained relatively constant until the 1980s, when their production capacity began to decline due to the exhaustion of developed reserves in Bisbee, the impending exhaustion of sulfide ore at Tyrone, and the closure of the high-cost New Cornelia mine. In 1986, PD purchased Kennecott's two-thirds interest in Chino Mines in New Mexico.

example, the mine and smelter built around 1881 could not handle the local carbonate ore very efficiently. New owners and an infusion of capital provided a branch railroad, a new smelter, and new underground mine development during the 1890s, which made the Old Dominion mine at Globe profitable.<sup>14</sup> Even where technological or other changes do not occur, a mine must expand into an ore body to maintain grade and output.

Capital became even more important in the early 1900s, when economies of scale (i.e., high capital cost but low unit operating costs) allowed development of low grade porphyry ore deposits and new types of smelters (see ch. 6). The capability to exploit these ores profitably started the next wave of consolidation in ownership as companies scrambled to acquire rights to porphyry deposits held by individual prospectors. During this period, two other firms moved to consolidate their holdings within the domestic copper industry: Kennecott (dating from the early 1900s and

financed in large part by Guggenheim family interests) became the other preeminent mining firm, and the American Smelting and Refining Company (now Asarco) was funded by Morgan banking interests to provide downstream processing. (Asarco originally owned and operated the smelter and refinery at Kennecott's Bingham Canyon mine.) Kennecott originally was formed to develop the Bonanza copper deposit in Alaska. Subsequently they acquired or developed mines in Ely, Nevada; Ray, Arizona; and Chino, New Mexico.

The search for mineral rights also extended to foreign countries, including the modern development of the first major properties in Chile, Peru, and northern Mexico (e.g., El Teniente and Chuquibambilla in Chile, Cerro de Pasco in Peru, Cananea in Mexico). This represented the first major period of foreign expansion by Anaconda, Kennecott, and Asarco.

The next wave of new copper mines in the United States resulted from the increase in demand due to post-World War II industrial devel-

<sup>14</sup>Ira B. Joralemon, *Copper: The Encompassing Story of Mankind's First Metal* (Berkeley, CA: Howell-North Books, 1973).

opment and the technological advance that permitted exploitation of lower grade ore bodies. While most of the players remained the same, there were a few notable new entrants. Asarco went into the mining business in Arizona to provide feed for its own smelters. Newmont Mining Company (through various subsidiaries, including Magma), Cyprus Mines, and Duval also began copper mining in Arizona and Nevada. Inspiration began consolidating its holdings in Claypool, Arizona.

Then in the 1970s, major oil companies expanded into the copper business, in part as a response to increased government control of foreign oil operations, and in part for diversification given the projected rapid dwindling of oil reserves. Arco bought Anaconda, Amoco (Standard Oil of Indiana) acquired Cyprus Mines, Pennzoil purchased Duval, and Louisiana Land and Exploration bought Copper Range. SOHIO bought Kennecott, then British Petroleum (BP) took over SOHIO. Cities Service acquired Miami Copper (Arizona) and Tennessee Copper, then Occidental bought Cities Service. EXXON, Shell, Hudson Bay, and Superior Oil also purchased copper properties. By 1983, mines owned by oil companies accounted for around 10 percent of the total production from the world's 50 largest mines.<sup>15</sup>

The extensive movement of oil companies into the copper industry was greeted with enthusiasm because it was thought to mean large amounts of capital for capacity expansions and modernization to meet anticipated burgeoning demand.<sup>16</sup> However, most oil companies found this diversification venture disappointing. Their managers often did not understand the cost and operational implications of the huge tonnages of material needed to produce hard-rock minerals. The companies **also** did not fully anticipate the long payback periods for capital investment in non-fuel mining. The rapid drop in oil and copper prices and in copper demand in the early 1980s,

<sup>15</sup>Kenji Takeuchi et al, *The World Copper Industry: Its Changing Structure and Future Prospects* (Washington, DC: World Bank Staff Commodity Working Papers, Number 15, 1987).

<sup>16</sup>Louis J. Sousa, *The U.S. Copper Industry: Problems, Issues, and Outlook* (Washington, DC: Bureau of Mines, U.S. Department of the Interior, October 1981).

plus the government appropriation of numerous foreign properties, compounded their cash flow problems. In the United States, only BP is still in the copper business, with one operation—Bingham Canyon. Cities Service sold its Arizona properties to Newmont. Amoco spun off Cyprus Minerals with sufficient capitalization to purchase additional mines. Arco/Anaconda sold its Arizona and Montana mines and wrote off the Nevada properties.

Since 1985, four other major shifts in ownership occurred in the U.S. copper industry. First, Copper Range—reorganized and staffed primarily with White Pine mine employees—bought the mine and smelter from Echo Bay. Copper Range is 70 percent owned by an Employees Stock Option Plan and 30 percent by Mine Management Resources. Second, Kennecott sold Ray Mines to Asarco (significantly increasing Asarco's presence in copper mining), and its share in Chino Mines to PD (partially replacing PD's soon-to-be-exhausted Tyrone deposit and closed Douglas smelter). Third, Newmont spun off Magma (including Pinto Valley) with sufficient recapitalization to finance modernization of the mine and smelter. Fourth, Cyprus Minerals acquired Duval's, Noranda's, and Inspiration's Arizona properties, making it the second largest copper producer in the United States.

## The Expansion of State Mining Enterprises

A second major change in the structure of the world copper industry resulted from a dramatic increase in government participation in production—especially in less-developed countries (LDCs). In 1960, governments had some influence in less than 3 percent of all NSW copper mine capacity, but by 1970, about 43 percent of NSW capacity was owned in whole or in part by governments.<sup>17</sup> In 1981, governments owned a majority share in 35 percent of NSW copper mine capacity, but in LDCs the ownership shares were much larger; 73 percent of LDC capacity had at least 5 percent government ownership, while 62 percent had majority State ownership.

<sup>17</sup>Sir Ronald Prain, *Copper: The Anatomy of an Industry* (London: Mining Journal Books Ltd., 1975).

Government control of smelting and refining capacity was even greater (see table 3-1).<sup>18</sup> The Bureau of Mines estimates that 65 percent of NSW demonstrated copper resources in 1985 had government involvement through direct ownership of copper production, including 100 percent of Codelco (Chile) and 60 percent of Zambia Consolidated Copper Mines Ltd-ZCCM (Zambia)<sup>19</sup>—the two largest NSW copper producing companies.<sup>20</sup> The major ownership changes that contributed to this trend are discussed in box 3-C and shown in table 3-2.

The expansion of State influence in copper production activities had an enormous effect on world copper markets in recent years. State investment decision making often is governed by objectives other than profitability; goals such as maintaining employment and self-reliance of supply or creating foreign exchange may carry as much or more weight. In Zambia, for example, maintaining copper production is essential because sales of the co-products, copper and cobalt, account for 90 percent of foreign exchange

earnings. With such goals, production and marketing strategies in State mining enterprises are less sensitive in the short term to cyclical market fluctuations, unlike private operations that must react to declines in demand and price. As a result, State enterprises tend to produce at full capacity regardless of market conditions.

Over the long term, however, substantial operating losses will mean an inability to meet interest payments on debt. In Mexico, the \$104 billion foreign debt, combined with the inefficient management and operating losses at State-run enterprises, led to a recently announced government policy of divestiture. The Cananea Mine and smelter, located about 15 miles south of the U.S. border in Sonora, is the first enterprise offered for sale. Cananea, which has a capacity of 160,000 tonnes per year, is owned by NAFINSA, a government bank. It is expected to generate around \$100 million (U. S.) in export earnings in 1988. Cananea reportedly has not shown a profit for at least eleven years, however. Recently, the La Caridad mine and smelter (about 75 miles south of the border at Nacozari, Sonora) were added to the sales list. La Caridad is owned and operated by Mexicana de Cobre, the State copper firm.<sup>21</sup>

<sup>18</sup>Marian Radetzki, *State Mineral Enterprises* (Washington, DC: Resources for the Future, 1985).

<sup>19</sup>The Zambia percentage given here reflects a correction to the Bureau of Mines report made following a private conversation with the author of that report.

<sup>20</sup>U.S. Bureau of Mines, *An Appraisal of Minerals Availability for 34 Commodities* (Washington, DC: U.S. Department of the Interior, Bureau of Mines Bulletin 692, 1987).

<sup>21</sup>James H. Maish, "Planned Sale of Copper Mine Stirrs Emotions in Cananea," *The Arizona Daily Star*, July 5, 1988.

**Table 3.1.—Government Ownership in the Copper Industry, 1981**

	Copper metal content		
	Mining	Smelting	Refining
<b>Western world:</b>			
Total capacity (1,000 tons) . . . . .	7,820	8,780	9,120
Percent of capacity with at least 5% government ownership . . . . .	40.5	30.6	25.9
Percent of capacity with majority government ownership . . . . .	34.7	29.7	24.3
<b>Developing countries:</b>			
Total capacity (1,000 tons) . . . . .	4,120	3,340	2,580
Percent of capacity with at least 5% government ownership . . . . .	73.0	75.5	82.6
Percent of capacity with majority government ownership . . . . .	62.0	72.9	77.0

SOURCE: Marian Radetzki, *State Mineral Enterprises* (Washington, DC: Resources for the Future, 1988)

### Box 3-C.—Increased Government Control in the World Copper Industry

The dramatic increase in government control over copper production facilities may be attributed primarily to the rise in nationalism in the early 1960s, **which led to a desire for sovereignty over local industry. Countries perceived mineral resources as part of their national heritage; control of those resources by foreigners was seen as at least improper and at most as thievery. Sovereignty over minerals was achieved through outright nationalization, through negotiations for majority share of ownership, or through legislation “encouraging” the sale of control to national firms.**<sup>1</sup>

The wave of nationalizations began in Zaire in 1967. Shortly after achieving independence from Belgium, Zaire nationalized Union Minière du Haut Katanga—the Belgian copper company formed in the late 1800s—and took over all of its assets and concessions. Générale Congolaise des Minerais (GEXAMINES) was formed to control copper mining. This was followed in 1969 by government “purchases” of a 51 percent interest in all mining properties in Zambia (ZCCM) and in the large mines in Chile (CODELCO). In 1971, the Chilean government passed a law in which the remaining interests in the major copper mines came under formal national control. Subsequently, Chile also set up a state-owned smelting and refining company—Empresa Nacional de Minería (ENAMI). Today, however, around 8 percent of Chile’s production is from privately-owned mines, and this percentage will increase dramatically when the Escondida project opens.<sup>2</sup> In Zambia, management and marketing continued under the former owners until 1974, when these functions were taken over by the government. Government ownership increased to 60 percent in 1979.<sup>3</sup>

In 1974, Peru nationalized the Cerro de Pasco mine: and the La Oroya smelter/refinery, which have since been operated as a state enterprise (Centromin Peru S.A.). A second Peruvian government company, Minería Peru, was established to control a number of major undeveloped ore bodies formerly owned by large international companies, including Anaconda and Asarco. Minería Peru began production at Cerro Verde in 1977. A third company, Empresa Minera Especial Tintaya S.A. (Tintaya) was formed in the 1980s. In 1986, however, the Southern Peru Copper Company (SPCC—jointly owned by Asarco, Phelps Dodge, Newmont, and the Marmon Group) accounted for 61 percent of Peru’s copper production (although all of SPCC’s output is marketed by a government agency).<sup>4</sup>

Finally, in the late 1970s, **Mexico passed legislation requiring a national equity share** in mineral properties. La Caridad (44 percent owned by the Mexican government) started production in 1980. Subsequently, 92 percent of the ownership in the Cananea Mine (started in the late 1800s) passed to the Mexican government.<sup>5</sup>

<sup>1</sup>Simon Strauss, *Trouble in the Third Kingdom* (London: Mining Journal Books Ltd., 1986); Louis J. Sousa, *The U.S. Copper Industry: Problems, Issues, and Outlook* (Washington, DC: Bureau of Mines, U.S. Department of the Interior, Oct. 1981).

<sup>2</sup>The owners of the Escondida copper project are: The Broken Hill Pty. Co. Ltd. of Australia, 60 percent; Rio Tinto Zinc Corp. Ltd., 30 percent; and Mitsubishi Corp., 10 percent.

<sup>3</sup>Sousa, *supra* note 1; Kenji Takeuchi et al., *The World Copper Industry: Its Changing Structure and Future Prospects* (Washington, DC: World Bank Staff Commodity Working Papers, No. 15, 1987).

<sup>4</sup>Janice L. W. Jolly and Daniel Edelstein, “Copper,” preprint from *1986 Bureau of Mines Minerals Yearbook* (Washington, DC: U.S. Department of the Interior, Bureau of Mines, 1987).

<sup>5</sup>Takeuchi, *supra* note 3; Jolly and Edelstein, *supra* note 4.

## International Financing and Subsidization<sup>22</sup>

International financing for copper projects may be sought directly, or may be obtained by a gov-

<sup>22</sup>Unless otherwise noted, the discussion of international bank financing and its impacts on the domestic copper industry are from Jerry Krim, “The Confessional Financing of Mining Capacity,” paper presented at the conference on Public Policy and the Competitiveness of U.S. and Canadian Metals Production, Golden, CO, Jan. 27-30, 1987.

ernment for general national development and then targeted for a copper project. A controversial aspect of increased government participation in world copper production capacity is the impact on production costs. Government-owned or influenced operations are seen by private producers as receiving substantial cost benefits in the form of lower taxes, government-provided infrastructure, and low-cost financing. They also are perceived as unresponsive to market condi-

**Table 3-2.—Government Acquisitions of Copper Capacity**

1967	Gecamines, Zaire	1000/0 nationalization
1969	Codelco, Chile	51 % takeover of major mines
1969	NCCM/RCM, Zambia <sup>a</sup>	51 % takeover of Zambia capacity
1971	Codelco, Chile	increase—51 % to 1000/0
1974	Cerro de Pasco, Peru <sup>b</sup>	1000/0 nationalization
1977	Cerro Verde, Peru	Start-up, 1000/0 government
1979	ZCCM, Zambia <sup>c</sup>	Government holding increased to 60°/0
1980	La Caridad, Mexico	Start-up, 440/0 government

<sup>a</sup>Nchanga Consolidated Copper Mines, Ltd. (NCCM) and Roan Consolidated Copper Mines, Ltd (RCM).

<sup>b</sup>Cerro de Pasco renamed Centromin.

<sup>c</sup>NCCM and RCM reorganized into ZCCM.

SOURCE: Marian Radetzki, *State Mineral Enterprises* (Washington, DC: Resources for the Future, 1985).

tions, and likely to be subsidized further during market downturns.

Low-cost financing is an especially touchy issue for domestic producers. State copper operations are largely in developing countries where considerable funding comes from international financial institutions, such as the World Bank, the International Monetary Fund (IMF), the Inter-American Development Bank, the Asian Development Bank, and the African Development Bank. The multilateral development banks' overall goal is to improve the standard of living in LDCs. The IMF's goal is to promote international trade and a stable international monetary system; its loans are to governments for balance-of-payment purposes only, not specific ventures. Funds can be channeled into mining activities, however. For example, within the IMF, the Compensatory Financing Facility (CFF) assists governments that have balance of payments problems due to low prices for their principal commodity exports.

**The United States contributes to loans through these international banks and, by doing so, can be involved in the subsidization of competitors to the domestic mining industry** (i.e., to the extent that loans are granted at lower interest rates than could have been obtained without international bank participation; see below).

The major concerns of non-government copper producers with these financial arrangements include: 1) the comparative advantage to recipi-

ents of confessional financing, 2) the leverage effects of international financial institution lending, 3) the promotion of new or expanded copper production facilities without regard to current capacity or market conditions, and 4) the recipients resultant mounting debt.

Perceptions of the risk associated with a mining operation may be altered by the presence of international bank lending. While such loans generally represent a small portion of the capital needed for a project, international bank participation may provide more credibility to a project than it might otherwise have. The perceived reduction in risk may enable a mining venture to acquire financing at terms not available without international bank participation. This risk reduction is viewed as an advantage over competing private firms.

More than two-thirds of World Bank loans are provided at the interest rate at which the lending institution is able to obtain the funds. The U.S. Bureau of Mines estimates that a representative sample of loans made between 1980 and 1984 resulted in a net benefit to the borrower of 0.05 cents per pound of copper.<sup>23</sup> While this is less than 0.1 percent of the average price of copper during that period, it is important to note that Chile, the largest and one of the world's lowest cost copper producers, is a recipient of significant international bank financing.<sup>24</sup>

Perhaps the greatest impact from international bank financing on domestic copper producers in the 1980s has been the expansion of capacity in LDCs despite a world copper market already plagued by oversupply. During the 1982-85 slump, 60 percent of LDC copper producers maintained or increased production despite low prices and mounting inventories. Domestic output (and capacity) dropped sharply, while LDC

<sup>23</sup>*Comparison of International Financial Institutions and Private Sector Loan Terms for Non-Fuel Mineral Projects in Developing Countries*, (prepared by Price Waterhouse for the Bureau of Mines, U.S. Department of the Interior, contract No. J0156023, May 1986).

<sup>24</sup>In December 1982, CO DELCO also obtained a \$305 million private loan, the largest single foreign loan ever issued to Chile. The loan was financed by a syndicate of 25 foreign banks, including 14 in the United States. Janice L.W. Jolly and Daniel L. Edelstein, "Copper," 1982 *Bureau of Mines Minerals Yearbook* (Washington, DC: U.S. Department of the Interior, Bureau of Mines, 1983).

expansion, funded in part by such financing, exacerbated the situation.

Finally, countries that depend on copper exports for foreign exchange have mounting debt because copper price fluctuations adversely affected exchange earnings. These include Chile, Zambia, Zaire, Peru, and the Philippines—among our major world competitors. When copper prices were rising in the early 1970s, the trade balances and tax collections in these countries improved, and they were able to pay some of the interest on their foreign debt. When copper prices plummeted after the oil embargo and again in the early 1980s, however, their foreign exchange earnings and tax revenues also dropped. Their interest and amortization payments became troublesome, and all five countries had to borrow through the Compensatory Financing Facil-

ity. As of April 30, 1986, six countries had outstanding CFF/IMF loans totalling almost \$1.4 billion that were tied to problems arising from the loss of copper export earnings.<sup>25</sup>

Recent studies on international bank financing impacts on domestic manufacturing and mining operations have led to a reassessment of U.S. contributions to such loans. Recommendations to reduce or eliminate U.S. participation where a loan may have a significant impact on domestic mining or manufacturing industries have surfaced several times in proposed trade legislation over the last few years. These bills either did not pass Congress or were vetoed by President Reagan (see ch. 10).

<sup>25</sup>Simon Strauss, *Trouble in the Third Kingdom* (London: Mining Journal Books Ltd., 1986).

## PRICE STRUCTURE

Copper is traded in various stages of processing including concentrate; blister and anode; refined, semi-fabricated, and fabricated products; and scrap (see figure 3-1). Within these stages exists an even broader range of classifications of copper products, such as old and new scrap, wirebars, ingot, cakes, billets, etc. Most copper is traded—and its price determined—as refined cathode and rod (i.e., refined metal at least 99.99 percent copper), however (figure 3-2). The price structures for other types of the metal are determined by refined copper prices.

Copper may be sold either through contracts or on-the-spot trading on the commodity exchanges—the London Metal Exchange (LME) and the Commodity Exchange of New York (COMEX). Today, around 80 to 95 percent of trade involves contracts between refiners and semi-fabricators for cathode or rod; the remainder is sold in on-the-spot trading on the two exchanges. The players in these markets are described in box 3-D. Long-term contracts for ores and concentrates provide a hedge against market gluts, and lengthen the adjustment period when prices fall.

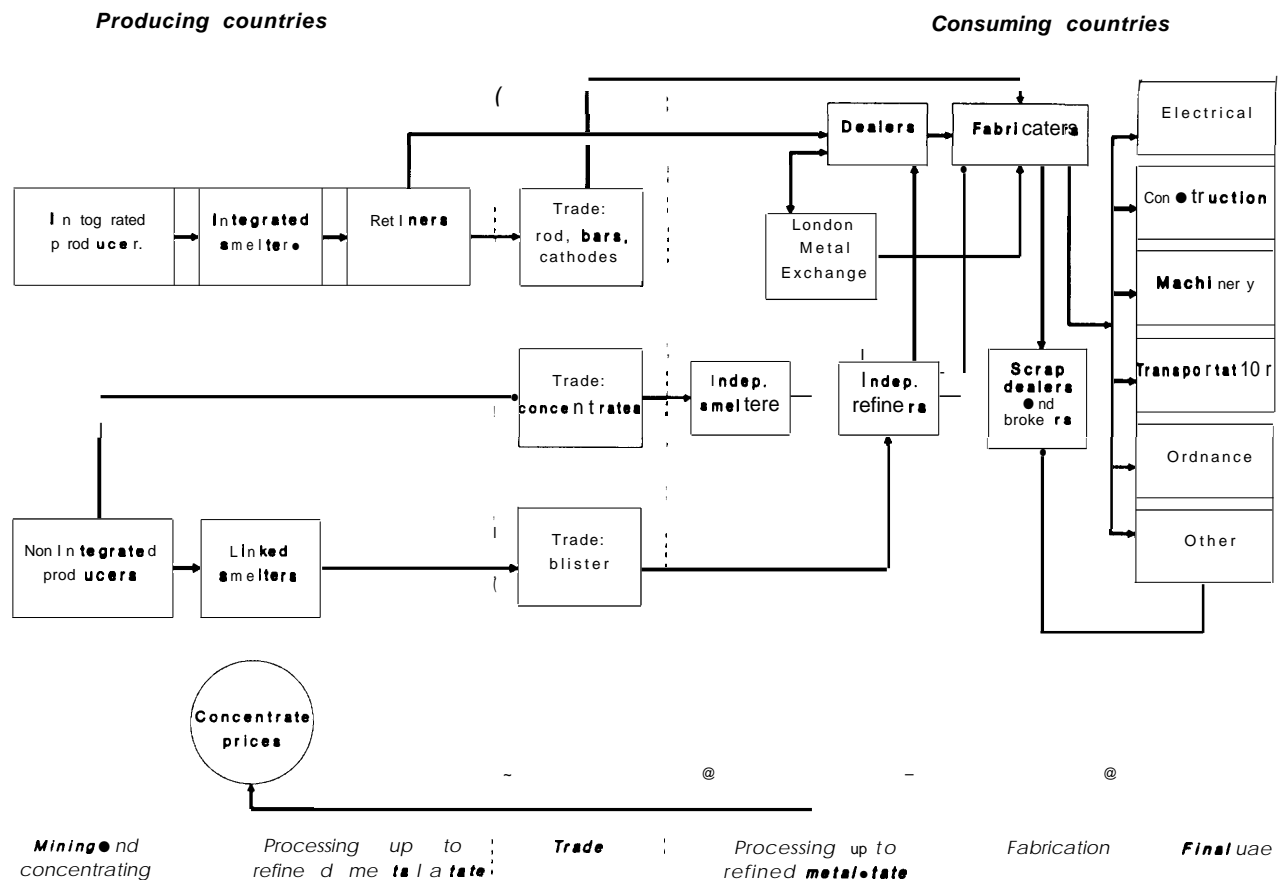
Copper is sold at commodity exchange prices, at prices published in journals such as *Metals*

Week, or at a published producer price. The *Metals Week* price is a weighted average based on daily tonnages and sales prices. A producer price is based on productive capacity, probable demand, level of competition, and cost of production (see table 3-3). Prior to 1978, most domestic (and Canadian) copper trade was at producer prices. Changes in the commodity exchange prices were met by adjustments to the producer prices. In the late 1970s, most domestic producers switched to COMEX pricing. Those still using the producer price have adopted flexible pricing policies, including more frequent adjustments in price following changes on the COMEX. Most transactions outside of the United States, including foreign shipments to domestic customers, are based on LME price quotations.

### The LME and COMEX

The amount of copper traded on the LME is a very small part of all copper trade, but this market plays an important role in setting the price. The LME serves as a “hedging” market—a clearing market for producers whose output exceeds their contracts, for small producers, and for accumulated inventories. Inventories in the LME are

Figure 3-1.-Copper Market and Price Structure



SOURCE: Walter C. Labys, *Market Structure, Bargaining Power, and Resource Price Formation* (Lexington, MA: D. C. Heath and Co., 1980)

an indicator of the balance of supply and demand in the world copper market (see below).

Copper is traded on the LME in the form of electrolytic cathode or high conductivity fire-refined copper in 25 tonne contracts. Delivery can be immediate (the next day) or in 3 months from approved LME warehouses. All trade occurs between the LME member and the customer. LME contracts usually do not contain a **Force Majeure** clause.<sup>26</sup> Margins and commissions are set by the exchange.<sup>27</sup>

<sup>26</sup>A **Force Majeure** is invoked when the supply of copper is curtailed for circumstances beyond the control of the parties involved, such as a strike or inclement weather.

<sup>27</sup>Robert T. Keck, "Understanding the Copper Futures Market, *Forecasting Commodity Prices: How the Experts Analyze the Markets*, Harry Jiler (ed.) (New York, NY: Commodity Research Bureau, 1975).

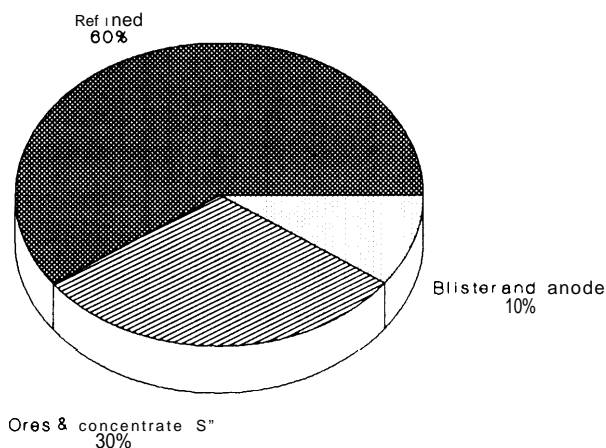
Price quotations on the LME are determined by transactions occurring during two daily trading sessions. These sessions last 5 minutes (12:00-12:05 pm and 3:40-3:45 pm, London time), with trade permitted to continue for 20 minutes following each session. Prices are quoted in pounds sterling and tenths of a pound sterling on a metric tonne basis, and may fluctuate without limit according to market activity.<sup>28</sup>

The COMEX differs from the LME in several ways. Trading on the COMEX is continuous from 9:50 am to 2:00 pm (New York time). COMEX prices are quoted in cents and tenths of a cent per pound of copper. Fluctuations in price are limited to 5 cents per pound per day.<sup>29</sup>

<sup>28</sup>bid.

<sup>29</sup>bid.

**Figure 3-2.—Most Copper Trade Occurs at the Refined Stage**



\*Copper content

SOURCE: World Bureau of Metal Statistics data

#### **Box 3-D.—Intermediaries in the Copper Market**

**Agents.**—Negotiate agreements between producers or consumers for a fee based on the value of the product sold.

**Merchants.**—Make direct purchases from producers and then sell the product to the highest bidder. Terms of acquisition are often more favorable than those obtained by agents or direct customer negotiation.

**Brokers.**—Buy and sell orders on the active metals exchanges for producers, consumers, and investors for a fee. If a broker handles both the buy and sell order, a commission is received for both actions.

Also, on the COMEX, copper is traded in the form of electrolytic cathode, or high conductivity fire-refined in 25,000 pound (12.5 short-ton) contracts. Futures contract sellers must have sufficient copper to deliver when the contract is settled. The delivery period extends up to 14 months, with deliveries occurring in January, March, May, July, September, October, or December. Deliveries are made from COMEX-licensed warehouses located across the United States and the point of delivery is the option of the seller. All

**Table 3-3.—Major Copper Price Quotations**

#### **London Metal Exchange (LME):**

Electrolytic wire bars, cash for immediate delivery in warehouse.

Up to W-day delivery, electrolytic wire bars.

Cash, electrolytic copper in the form of cathodes, by grade.

W-day, electrolytic copper in the form of cathodes, by grade.

#### **New York Producer Price:**

Domestic refinery price (*E&MJ*),<sup>a</sup> electrolytic wire bars. From January 1967, FOB domestic net Atlantic seaboard refinery.

Same price delivered which includes shipping cost.

Same price based on cathodes.

#### **New York Commodity Exchange (COMEX):**

Spot settlement price.

Futures Price.

#### **Federal Republic of Germany:**

Electrolytic copper wire bars

<sup>a</sup>*Engineering and Mining Journal price.*

SOURCE: Walter C. Labys, *Market Structure, Bargaining Power, and Resource Price Formation* (Lexington, MA: D.C. Heath and Company, 1980).

trade occurs through members, usually through a floor broker. Minimum margins and commissions are set by the exchange. A clearing house exists to record all member transactions and report net positions of the customers.<sup>30</sup>

#### **Direct Producer-Customer Contracts**

Most copper trade involves transactions between refiners and semi-fabricators. Contracts for primary refined copper are usually for 1 year. A contract typically specifies the total annual tonnage and the monthly delivery limits within which the buyer can make purchases.<sup>31</sup> Other specifications include point of delivery, packing, etc. Unlike most commodities, the price is not specified, but stated more generally in a pricing clause such as "the seller's price at the time of delivery."<sup>32</sup>

Ores and concentrates usually are sold in long-term contracts of 1 to 10 years. These contracts may be linked to financial agreements in which a smelter may provide financing for resource de-

<sup>30</sup>Ibid.

<sup>31</sup>U.S. International Trade Commission (ITC), *Unwrought Copper: Report to the President on Investigation No. TA-201-52 Under Section 201 of the Trade Act of 1974*, ITC Publication 1549 (Washington, DC: ITC, July 1984).

<sup>32</sup>Walter C. Labys, *Market Structure, Bargaining Power, and Resource Price Formation* (Lexington, MA: D.C. Heath and Company, 1980).



velopment in return for a percentage share of the mine's output. For example, 15 percent of production from Phelps Dodge's Morenci mine is for the account of Sumitomo Corporation. These financing arrangements and many long-term concentrates contracts are designed to facilitate the flow of raw materials to smelters with insufficient or no mining resources.<sup>33</sup> As noted above, they also can ease adjustment to market fluctuations.

Concentrates may be sold to a smelter directly, or may be toll smelted (i.e., processed by the smelter/refinery for a fee and then returned to the producer). In either case, the value of the concentrate is calculated based on the price of refined copper. The price set by the smelter is determined by a basic formula: LME (or U.S. producer) price, times percent copper content, less conversion fee, less unwanted byproduct removal charge, plus precious metal sale credit, plus other byproduct sale credit, minus transport cost (if paid by the smelter).<sup>34</sup> **In practice, for both direct sales and toll smelting, the price will vary with the negotiated terms and conditions of the contract,** such as byproduct clauses and the economic and cost conditions at the time of purchase (i.e., exchange rates). Blister and anode copper are sold on similar terms, i.e., prices are a function of the LME refined price.

### The Role of Inventories

The structure of the copper industry is such that production usually cannot be increased quickly due to the long leadtimes for new or expanded capacity. Nor can production levels always be reduced rapidly or in small increments because economies of scale require minimum production levels and there are significant exit costs for shutting down capacity.

Therefore, consumers, producers, and speculators may stockpile copper to guard against (or profit from) shifts in supply and demand, inflation, and exchange rate adjustments. Speculators on the exchanges also may hold inventories in anticipation of price shifts. Finally, copper consumers may find themselves with unwanted in-

ventories as a result of unanticipated reductions in demand for their products.

In general, producers and consumers maintain stocks as a precautionary measure. Continuation of supply is critical for most consumers, who may hold inventories to guard against possible supply disruptions and sudden price increases (e.g., due to labor strikes, transportation problems, or adverse weather). Producers may stockpile copper awaiting an increase in price, or in anticipation of events such as labor strikes in order to meet future contractual obligations. Both of these practices were more pronounced prior to the 1980s, when the cost of holding stocks was less significant to a company's balance sheet. Cost is less significant for those consumers who hold inventories to ensure an uninterrupted flow of **materials for manufacturing activities that have a high down-time cost**, however.

Because planned inventories are used by both copper producers and consumers as a "hedge," they are considered an important indicator of the balance between supply and demand. Changes in inventories mirror shifts in market conditions, and significant changes are usually reflected in the market price. Short-term changes in inventories usually mean temporary or cyclical fluctuations in consumption or production. Long-term inventory surpluses or shortages may imply more fundamental structural changes in copper demand, such as decreased intensity of use or a need to expand world production capacity.

### Near-Term Price Determinants

Near-term prices (1 to 3 years) tend to fluctuate in response to normal business cycles through their effects on consumer demand. Price shifts may be exaggerated by speculative actions, however. For, example, in late 1987, copper prices began to rise as inventories dropped. The average price of copper for the first half of the year was about 66 cents per pound—up only a few cents from 1986. This minor increase, however, led to anticipation of a tighter copper market and a subsequent increase in copper sales to investors. The increased demand by speculators tightened the market even further, and by the end of 1987 spot prices had soared to nearly \$1.50

<sup>33</sup>The smelters in Japan are almost completely reliant upon imported raw materials to feed their facilities; see ch. 4.

<sup>34</sup>Labys, *supra* note 31.

per pound.<sup>35</sup> Some investment analysts even suggested that someone was trying to “corner” the copper market as the Hunt brothers had exploited market conditions in an attempt to corner the silver market in 1979.<sup>36</sup>

Near-term copper price movements also are tied to the relative inelasticity of world copper supply and demand, which in turn may mask longer-term effects. As noted previously, copper production capacity is slow to respond to both increases and decreases in demand. Thus, during the early 1980s, many major copper producers perceived the downturn in demand and price as part of the general economic recession. When copper prices were much slower to respond to the economic recovery in the United States than other sectors, however, more fundamental changes in the world copper industry (e.g., due to new market entrants, substitution, and third world debt) were recognized.

### Long-Term Price Determinants

**In the long term (5 years and beyond), prices are determined by the structure of the market, including:** the degree of ownership concentration (and thus market control) among producers and consumers; economic forces, such as technological change leading to radical shifts in production costs or consumer demand; and investment patterns, including the extent of government participation. For the copper industry, some noteworthy structural, economic, and technological factors may play an important role in long-run pricing. First, long-term contracts for ores and concentrates are likely to become more prevalent as the location of new smelting capacity is increasingly dictated by environmental concerns.

Second, concentration of ownership in the industry, particularly mining, has become more diluted. While the most recent sales of domestic capacity have, for the most part, meant fewer companies involved in domestic production, more countries have entered the market. While the trend toward State control of production at foreign copper properties is likely to continue,

ownership probably will widen as burgeoning third world debt makes it increasingly difficult for LDCs to obtain project financing. Thus their cost of capital will be higher without significant private participation or development bank help.

Third, greenfield copper capacity additions have leveled off, and the surplus capacity that existed during the early 1980s is declining. While new capacity is planned for the next 5 years, it may be partially offset by exhaustion or cutback of existing operations, combined with demand growth created by new or expanded applications. Potential influences on future supply and demand are discussed—but not predicted—in more detail in chapter 4.

Fourth, the application of leaching and solvent extraction-electrowinning (SX-EW) technologies has made possible the recovery of copper from lower grade ores at a low cost. This is a double-edged sword for the domestic copper industry. While the United States has large oxide and waste dump reserves from which the domestic industry can produce copper for as low as 30 cents/lb, this production can exert downward pressure on world prices. Moreover, technology transfer in the copper industry is almost instantaneous, and SX-EW is particularly attractive to debt-ridden LDCs because of its low capital cost and undemanding operational requirements (see ch. 10).

Technologies affecting demand also play an important role in setting long-term copper prices. The impact of these innovations is as uncertain as future supply, however. Even the effects of technologies now on the drawing board, such as superconducting materials and their applications, are highly uncertain (see ch. 4). Completely unanticipated innovations could make or break the copper industry by replacing the metal in critical applications or providing broad new uses.

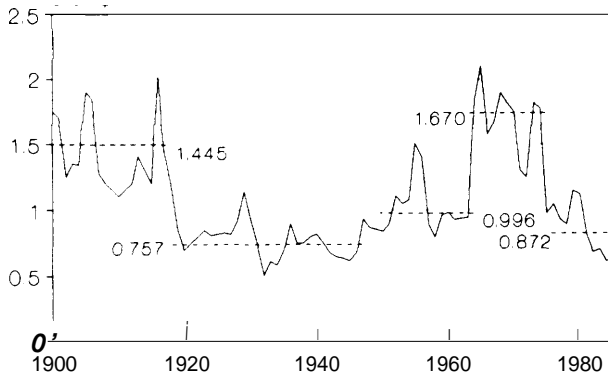
### The Effects of Price Instability

Copper prices historically have been volatile (see figure 3-3). A large portion of copper consumption is in electricity, construction, and transportation—industrial sectors normally associated with economic growth and development. Copper demand is so sensitive to these sectors that it tends to fluctuate much more wildly than

<sup>35</sup>Ibid.

<sup>36</sup>“Who’s Squeezing Copper,” *Forbes*, Feb. 8, 1988.

**Figure 3-3.-London Copper Price**



SOURCE Kenji Takeuchi, *The World Copper Industry Its Changing Structure and Future Prospects* (Washington, DC The World Bank, 1987)

they do (see box 3-E). Demand for copper grows radically during periods of industrial expansion and experiences severe declines when industrialization wanes. These swings in world demand are usually reflected in prices on the exchanges, where even a few large buy or sell orders can drastically affect short run prices.

Unstable copper prices create difficulties for both producers and consumers. Economic forecasting by management prior to deciding to proceed with an operation includes a prediction of anticipated copper prices. With volatile prices, such predictions are very difficult. Indeed, it was the relatively steady price increases of the late 1960s and early 1970s, combined with the increase in demand prompted by the Vietnam War, that encouraged the opening of so many new mines in the early 1970s. But the inability to predict the oil embargo with its ensuing recession quickly burst this bubble. A second severe recession within 5 years meant record copper inventories, and tolled the death knell for many mines.<sup>37</sup>

Unstable prices also make it difficult for copper consumers to plan their production line. For a given application (e. g., automobile radiators), copper may be the best choice at a given price. But if copper prices rise, aluminum or plastics may be preferred. If the manufacturer changes

to another material, and then copper prices go down, he must decide whether to revert to copper. Frequent switches are difficult, however, because changes in raw materials usually mean changes in design, in production equipment, and in labor skills.<sup>38</sup>

If copper has certain properties that require that it be used regardless of cost, the manufacturer loses control of his production cost. Changes in the cost of copper may mean losses on inventories when prices go down, or more cash tied up in stocks when prices rise. Moreover, the consumer is faced with frequent adjustments to prices and difficulty in maintaining profit margins.<sup>39</sup>

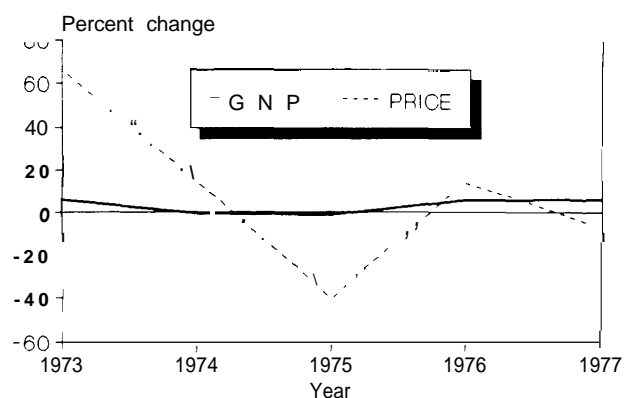
Unstable copper prices also create major problems for countries that depend on copper exports for foreign exchange. When copper prices are high, such countries enjoy improved balances of trade and tax revenues, and are able to pay interest on their foreign debt. When copper prices are low, however, their foreign exchange earnings and tax revenues decline, and they may be forced to borrow from the Compensatory Financing Facility of the International Monetary Fund to meet interest and amortization payments. As noted previously, as of April 30, 1986, 6 countries had outstanding CFF/IMF loans totalling almost \$1.4 billion that were tied to problems arising from loss of copper export earnings.<sup>40</sup>

<sup>38</sup>bid.

<sup>39</sup>bid.

<sup>40</sup>bid.

**Figure 3-4.-GNP Compared to Copper Price (1973-77)**



LME price

SOURCE Office of Technology Assessment.

<sup>37</sup>Strauss, supra note 24.

### Box 3-E.—The Volatility of Copper Prices and Demand

Figure 3-4 contrasts the changes in U.S. gross national product (as an indicator of general economic growth) with the average annual copper price for the years 1973 to 1977. These were years of radical economic change. 1973 had been the year of greatest economic activity yet recorded. Then the boom halted abruptly in mid-1974 as the effects of the oil embargo began to be felt in steeply rising energy prices. This was followed by a severe recession in 1975, with fairly rapid recovery in 1976 to 1977. Despite these radical economic conditions, GNP fluctuated by only a few percentage points during 1973 to 1977. In contrast with the single-digit percentage changes in GNP during these years, copper prices rose or fell by double-digit percentages. **The price went from a 1972 (pre-oil embargo) average of 48.5 cents/lb on the London Metal Exchange, to a 1974 average of 93.1 cents/lb, and back to 59.4 cents/lb for 1974.**<sup>1</sup>

Demand also was very volatile over the same period, going from 2.2 million tonnes in 1973 and 1974, to almost 1.5 million tonnes in 1975. It then increased to 1.9 million tonnes in 1976 and 2.1 million tonnes in 1977.<sup>2</sup> The volatility of copper consumption arises from the large proportion of demand that is linked to industrial capital expenditures, construction activity, and major consumer durable items such as automobiles and appliances.<sup>3</sup> In addition to general economic trends, U.S. copper demand in the 1970s was affected by significant structural changes related to substitution. Copper's intensity of use fell about 25 percent between 1970 and 1980, primarily due to automotive and products downsizing, design changes to conserve materials or increase efficiency, and substitution by aluminum.<sup>4</sup>

<sup>1</sup> U.S. Bureau of Mines, *Minerals Yearbook*, various years.

<sup>2</sup> Ibid., U.S. consumption of primary copper plus old scrap.

<sup>3</sup> Simon Strauss, *Trouble in the Third Kingdom* (London: Mining Journal Books Ltd., 1986).

<sup>4</sup> U.S. Bureau of Mines and U.S. Department of Commerce, *Domestic Consumption Trends, 1972-82, and Forecasts to 1993 for Twelve Major Metals* (Washington, DC: U.S. Department of the Interior, Bureau of Mines Open File Report 27-86, January 1986).

**Chapter 4**

# **Market Structure**

# CONTENTS

	<i>Page</i>
Overview . . . . .	63
Domestic and World Copper Supply . . . . .	65
Capacity . . . . .	65
Capacity Utilization . . . . .	66
Mining . . . . .	66
Smelting . . . . .	69
Refining . . . . .	70
Leaching and Solvent Extraction/Electrowinning . . . . .	72
Future Supply Considerations . . . . .	74
Demand . . . . .	76
Properties and Uses. . . . .	76
World Consumption . . . . .	77
Technology and Future Demand . . . . .	79
Trade . . . . .	80
Concentrates . . . . .	83
Blister and Anode . . . . .	83
Refined . . . . .	84
Copper Markets in Centrally Planned Countries . . . . .	84

## Box

<i>Box</i>	<i>Page</i>
4-A. Phelps Dodge and SX-EW Processing . . . . .	74

## Figures

<i>Figure</i>	<i>Page</i>
4-1. Average London Metal Exchange Price, 1980-86 . . . . .	63
4-2. World Copper Mine Capacity . . . . .	66
4-3. Copper Mine Production in the Market Economy Countries. . . . .	67
4-4. Trends in Mine Production, 1970-86 . . . . .	68
4-S. Productivity in the U.S. Copper industry, 1973-86 . . . . .	69
4-6. Primary Smelter Production: The U.S. Share Has Declined . . . . .	70
4-7. Primary Smelter Production: 1970, 1980, 1986 . . . . .	71
4-8. Primary Refinery production, 1986 . . . . .	71
4-9. U.S. Production of Refined Copper by Source, 1970-86 . . . . .	72
4-10. Distribution of Electrical and Electronics Uses in Copper Demand . . . . .	78
4-n. U.S. Copper Demand by Sector: 1979, 1982, 1986 . . . . .	78
4-12. Refined Copper Imports as Percent of Domestic Refined Consumption . . . . .	84

## Tables

<i>Table</i>	<i>Page</i>
4-1. Overview of U.S. and world Copper Markets: 1980-86 . . . . .	64
4-2. Solvent Extraction/Electrowinning Capacity . . . . .	75
4-3. U.S. Copper Trade, 1970) and 1986 . . . . .	82
4-4. 1986 Concentrate Trade . . . . .	83
4-5. 1986 Blister and Anode Copper Trade . . . . .	83
4-6. 1986 Refined Copper Trade . . . . .	84
4-7. Copper Production in Centrally Planned Countries . . . . .	85

# Market Structure

During the 1980s, copper companies worldwide struggled to adjust to a changing market environment. Western world' copper production capacity grew, while consumption declined in industrialized economies due to the 1982-83 **global recession and the aftershock of the energy crisis**. Copper demand in less developed countries (LDCs) also was lower than expected as funding for industrial development declined sharply with staggering energy bills and growing international debt. Thus, supply increased steadily despite decreases in demand and the real price of copper during the first half of the decade (see figure 4-1). Significant expansions in government-influenced production capacity, particularly in LDCs, altered the structure of both the industry and the market. From 1980 to 1983, inventories mounted and prices dropped, forcing higher cost operations to reduce output or close. The domestic industry, because of its high wages, strict environmental regulations, and low ore grades, included many high-cost producers and absorbed much of the impact of the shrinking world market. Between 1981 and 1986, U.S. mine production declined 24 percent, while total Non-Socialist World (NSW) mine output fell less than 1 percent.

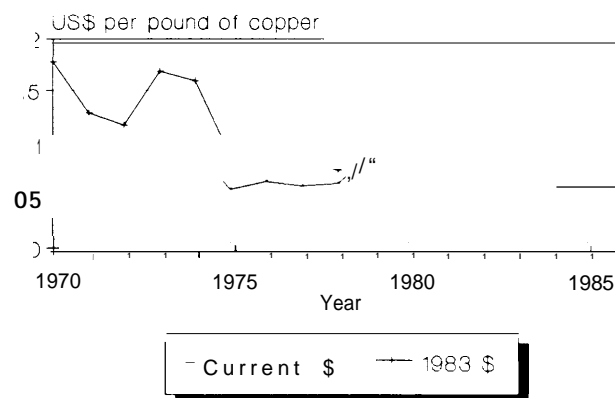
<sup>1</sup>All data in this chapter, unless specifically stated otherwise, are limited to the Western world, also termed the market economy countries, or the Non-Socialist World (NSW). These refer to all copper producing and consuming market economy countries. This includes Yugoslavia, but excludes Albania, Bulgaria, Czechoslovakia, Cuba, Democratic Republic of Germany, Hungary, Poland, Romania, and the USSR. China is also excluded from consumption and production figures, but is included in trade figures because of the significant amount of copper imported into China from NSW countries in recent years. A brief description of copper activities outside the NSW market is provided at the end of this chapter.

At the beginning of this decade, the average price of copper on the London Metal Exchange (LME) was 99 cents/lb, and NSW stocks were just over 1 million tonnes,<sup>4</sup> and total refined produc-

<sup>3</sup>All monetary figures (\$ and cents) in this chapter are in current (or nominal) U.S. currency

<sup>4</sup>-Tonnes refers to metric tons (2204.6 pounds).

**Figure 4-1.-Average London Metal Exchange Price, 1980-86**



SOURCE U S Bureau of Mines data

This chapter reviews the current status of copper markets—supply, demand, and trade—for the United States in particular and the Western world as a whole. The chapter begins with an overview of the events and trends in copper markets since 1980 that shaped the status quo. It then describes copper supply (in capacity, and mine, smelter, and refinery output) and consumption patterns (by product and industrial sector). It also discusses supply and demand trends that are likely to shape the industry for the remainder of this century. Finally, the chapter analyzes recent trends in international trade in copper concentrates, blister and anode copper,<sup>2</sup> and refined products.

<sup>2</sup>Blister is the copper produced by smelting and converting; it is converted to anodes in fire refining (see ch. 6)

## OVERVIEW

tion and consumption were both around 7.1 million tonnes (see table 4-1). That was the post-WWII heyday for the U.S. copper industry. In 1982, when the recession began to ripple through the economy, consumption decreased slightly to 6.8 million tonnes, prices dropped by 32 percent to 67.1 cents/lb, refined copper production rose

**Table 4-1.—Overview of U.S. and World Copper Markets: 1980-86**  
(nominal U.S. cents/lb and 1,000 tonnes)

	1980	1982	1984	1986
Average LME price . . .	99.25	67.14	62.45	62.28
<b>Stocks</b>				
U.S. <sup>a</sup> . . . . .	314	695	564	225
NSW total <sup>b</sup> . . . . .	703	1,100	1,200	796
<b>Total refined production</b>				
U.S. . . . .	1,726	1,694	1,490	1,479
NSW total . . . . .	7,070	7,233	7,275	7,523
<b>Refined consumption</b>				
U.S. . . . .	1,862	1,658	2,123	2,122
NSW total . . . . .	7,101	6,776	7,666	7,672

<sup>a</sup>Includes blister and materials in process of refining, plus refined copper held by primary producers, wire and brass mills, and the New York Commodity Exchange.

<sup>b</sup>Includes inventories of refined copper held by the New York Commodity Exchange, the London Metal Exchange, and world refined-copper producers.

<sup>c</sup>Includes primary and secondary refinery output.

SOURCE Office of Technology Assessment, from Bureau of Mines and WBMS data

slightly to nearly 7.2 million tonnes, and inventories shot up nearly 60 percent to about 1.6 million tonnes.<sup>5</sup>

The short-term factors that caused the market downturn include the high interest rates and weak industrial economic growth that began during the recession. Over the long term, the shift of many developed countries away from manufacturing to service industries; the miniaturization of many electronic parts; the downsizing of automobiles; and the substitution of other materials for copper (primarily aluminum, plastics, and fiber optics) aggravated the drop in demand.<sup>6</sup> Finally, the strong U.S. dollar favored imported copper.

Not all operations adjust their output in response to changes in demand and price; producers consider factors other than current market conditions. Social goals, such as maintaining employment levels and foreign exchange earnings, are important to government-influenced operations. The market conditions for co-product metals are another major consideration. Third, mines that must meet long-term contracts with smelters for concentrates maintain production despite low

<sup>5</sup>World Bureau of Metal Statistics (WBMS), *World Metal Statistics Yearbook 1987* (May 1987).

<sup>6</sup>*Domestic Consumption Trends: 1972-82, and Forecasts to 1993 for Twelve Major Metals* (Washington, DC: U.S. Department of the Interior, Bureau of Mines, IC 9101, 1986), p.14.

prices and weak demand. The costs of closing or slowing down an operation also play a role in determining output levels. The influence of all these factors was evident in 1982 when, despite declining demand and prices, 60 percent of the copper producers maintained or increased production. Inventories climbed by 36 percent as a result.

Demand remained stagnant until the economic recovery belatedly reached the copper industry. By 1984, consumption rose to 7.7 million tonnes with refined production at 7.2 million tonnes (see table 4-1). Consequently, inventories dropped to 1.2 million tonnes.<sup>7</sup> Even with stronger demand and the reduction of world stocks, however, copper prices stayed low; the average LME price in 1984 was 62.5 cents/lb.

**The failure of copper prices to improve in response to the revived market left many domestic producers scrambling to survive.** Following the sharp drop in 1982, NSW copper mine production inched upward while U.S. mine production fell slightly. **For most domestic producers, production cutbacks became necessary and high cost mines were closed—some permanently.** The U.S. Bureau of Mines estimates that the mine capacity of major U.S. producers fell nearly 20 percent between 1980 and 1984.<sup>8</sup> Reserves at a few mines that closed were depleted; other mines could only produce economically at prices well above \$1/lb. The remaining producers were operating at levels far below capacity, however. In 1983, U.S. copper mines operated at 58 percent of capacity, while Chilean mines produced at 97 percent of capacity.<sup>9 10</sup>

**Domestic producers, saddled with high labor costs, lower ore grades, a high-value dollar, and stringent environmental regulations had to re-**

<sup>7</sup>WBMS, supra note 5.

<sup>8</sup>Janice L.W. Jolly, "Copper," 1985 *Minerals Yearbook* (Washington, DC: U.S. Department of the Interior, Bureau of Mines, 1987), p. 327.

<sup>9</sup>Janice L.W. Jolly, "Copper," *Mineral Facts and Problems* (Washington, DC: U.S. Department of the Interior, Bureau of Mines, 1986), p. 201.

<sup>10</sup>Capacity utilization rates often cannot be compared due to the difficulties associated with defining and quantifying available capacity. However, it is important to note that a major difference in capacity utilization existed and that U.S. producers held significant idle capacity.



**duce costs if they were to compete in the world market.** Major changes such as wage and benefit concessions, capital investments in plant and equipment, revised mining plans (including higher cut-off grades and lower stripping ratios), overhead reductions, productivity improvements, and debt restructuring were instrumental in reducing costs (see ch. 10).

After peaking in early 1985, the dollar devalued against the currencies of other developed countries, such as Japan. This brought benefits for domestic smelters in 1986. Initially, the Japanese smelting industry attempted to retain its market share by maintaining dollar prices for treatment and refining charges. By December 1986, Japanese smelters, driven by mounting losses, were forced to raise these charges by as much as 50 to 80 percent to adjust for the weaker dollar.<sup>11</sup>

<sup>11</sup>D. Maxim, "Exchange Rate Developments and the Primary Copper Industry," paper presented at the conference on Public Policy and the Competitiveness of U.S. and Canadian Metals Production, Golden, CO, Jan. 27-30, 1987, p. 12.

Copper operations in countries such as Spain, Germany, and Finland also suffered from the devaluation of the dollar. The value of the dollar rose, however, against the currencies of Chile, Peru, Zambia, and Zaire, all major copper producers. This increased their profits in local currency terms.

By the end of 1986, the world copper industry showed signs of a revival. production and consumption reached the highest levels in 10 years and inventories dropped sharply—to less than half the 1983 level. In 1987, the recovery continued. Relatively strong demand (including increased speculation), plus supply disruptions in Canada, Zambia, and Peru, tightened the world copper market. Inventories fell to minimum levels and prices soared, providing a needed boost for both domestic and world producers.

## DOMESTIC AND WORLD COPPER SUPPLY

### Capacity

The copper industry is dynamic, with a constantly changing technical, corporate, and market environment. New technologies continue to reduce costs and facilitate mining even very low grade deposits. The nature of the industry—large and capital intensive projects requiring extensive exploration and development—often makes response to change slow, however. Entering and exiting the market are neither simple nor cheap. Exit costs are substantial and discourage closures unless market conditions are severe or reserves are exhausted.

Still, new sources of supply are needed to replace depleted ones. Even if copper demand continues to grow at its recent modest 2 percent annual rate or less, new mines will be needed to keep the market in balance. To examine the world copper supply outlook, and the role of the United States therein, it is essential to identify where supply and demand come from now, and where they are likely to originate in the future.

**Identifying potential sources of supply (i.e., ore bodies and their developers) is relatively simple, but determining the production capacity is more difficult.** Capacity is a function of many factors, including price, technology, costs, ore grade, and demand. Moreover, the definition of capacity varies among analysts. Some reports use the rated engineering capacity of equipment or plants, regardless of actual or potential operating status. Others use actual output for a given period, regardless of underlying economic and other conditions (e.g., labor strikes, bad weather, or temporary fluctuations in ore grade). Furthermore, some analysts do not include a mine's copper output in a country's capacity data if copper is not the primary metal produced (i. e., it is a by-product or coproduct of other metal mining). As a result, capacity estimates vary widely, and output can be considerably greater or much less than reported capacity.

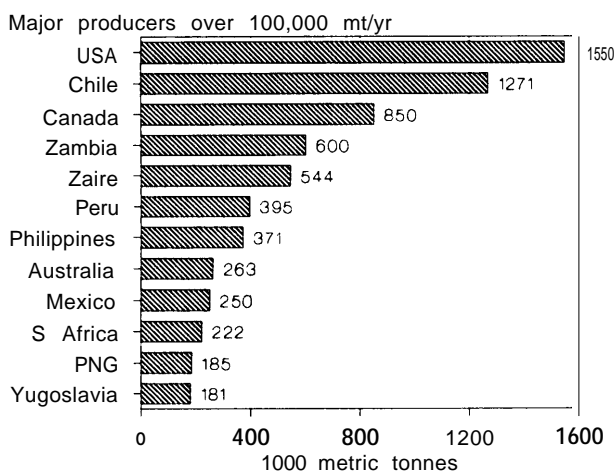
**The status of individual operations also is often ambiguous.** For example, facilities listed as temporarily shut down may be considered available capacity when, in fact, they are highly unlikely to reopen (e.g., equipment has not been maintained or has been cannibalized). The longer an operation remains idle, the less likely that it will resume production as technological advances increase the capital investment needed to re-enter the market. At the same time, corporate strategies postpone the high costs associated with permanent closure, substituting the lower maintenance costs of a "temporary" shut-down.

At the beginning of 1984, the U.S. Bureau of Mines estimated copper mine production capacity in 37 countries at 7.4 million tonnes per year (see figure 4-2).<sup>12</sup> Twelve countries had mine capacity greater than 100,000 tonnes, accounting for 90 percent of the total. The United States had the largest share, with nearly 1.6 million tonnes, followed by Chile with about 1.3 million tonnes. Canada, Zambia, and Zaire also have substantial capacity, with 850,000, 600,000, and 544,000 tonnes, respectively, in 1984.

As of January 1987, annual mine capacity of **producing** operations in the United States had

<sup>12</sup>Jolly, supra note 8.

**Figure 4-2.-World Copper Mine Capacity (1984)**



SOURCE The World Bank

dropped slightly to about 1.5 million tonnes.<sup>13</sup> Seventeen mines account for 92 percent of domestic capacity. Phelps Dodge has replaced Kennecott (now BP Minerals America) as the nation's largest copper producer. Phelps Dodge's capacity in four mines amounts to more than 530,000 tonnes (including 75,000 tonnes held by two Japanese partners), or 36 percent of domestic capacity. Also included in the domestic capacity total is nearly 200,000 tonnes from BP Minerals' newly reopened Bingham Canyon mine.

## Capacity Utilization

Copper's strong demand growth and high earnings in the 1960s (and much of the 1970s) stimulated exploration and development for new mines as well as expansions at existing facilities. The subsequent downswing resulted in a great deal of this capacity being idled. Very low capacity utilization rates frequently were cited to highlight the industry's distress, especially in the United States. **When prices rose so dramatically in 1987 and domestic production did not increase correspondingly, it became apparent that significant idle capacity was not waiting in the wings for improved market conditions.**

Spot shortages in copper markets during 1987 also imply that industry estimates of available (i.e., economically re-openable) capacity were high. One estimate suggests that "only 45 percent of the 0.9 million tonnes of mine capacity on standby at the end of 1985 was genuinely re-openable."<sup>14</sup> Comparing 1986 Western world production data to an International Wrought Copper Council estimate of available capacity yields utilization rates of 82.6 percent, 86 percent, and 87.5 percent for mines, smelters, and refineries, respectively.<sup>15</sup>

## Mining

Since 1970, 52 market economy countries have reported copper mine production. In 1986, NSW

<sup>13</sup>Simon Strauss, "Copper: In 1986 the Metal Belied its Reputation for Volatility," *Engineering and Mining Journal*, March 1987.

<sup>14</sup>P.C.F. Crowson, "Aspects of Copper Supplies for the 1990s," paper delivered at Copper 87, conference held in Chile, November 1987.

<sup>15</sup>Ibid.

copper mines produced 6.66 million tonnes. **While nearly 40 Western countries reported mine production, eight—Chile, the United States, Canada, Zambia, Zaire, Peru, Australia, and the Philippines—accounted for 78 percent of total mine output (see figure 4-3). '6**

**The U.S. industry led the world in copper mine production for over a century, but lost that position to Chile in 1982.** As shown in figure 4-4, Chile's copper industry has been growing rapidly, with mine output nearly doubling from 1970 to 1986. At the same time, U.S. copper production was declining; in 1986 it was 27 percent lower than in 1970. Zaire and Canada show modest growth, while Zambian production has declined slightly. Output from the numerous other producers has increased sharply, due in part to strong growth in countries that already had established mining industries (e.g., Mexico and Peru), and in part to the appearance of new producers such as Papua New Guinea and Indonesia.

Chile mined nearly 1.4 million tonnes in 1986 (21 percent of total output). Corporation del Cobre de Chile (Codelco—Chile's nationalized copper company), announced ambitious plans

<sup>16</sup>Janice L. W. Jolly and Daniel Edelstein, "Copper," preprint from 1986 Bureau of Mines Minerals Yearbook (Washington, DC, U.S. Department of the Interior, Bureau of Mines, 1987).

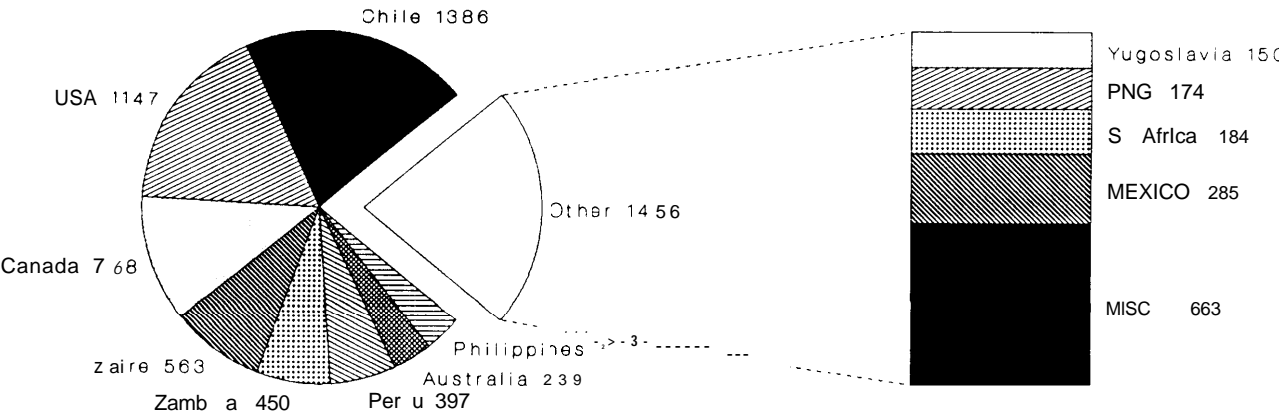
for expanding mine production, but budget constraints prevented their implementation.

In 1986, the U.S. industry continued to recover from its weak 1983 level, increasing mine production almost 4 percent to around 1.2 million tonnes (17 percent of NSW total). Arizona accounted for nearly 70 percent of U.S. output, with New Mexico and Michigan in second and third places. In total, 87 mines located in twelve States produced copper in 1986; at 61 of these, copper was the primary product, and at 26 it was a byproduct of gold, lead, silver, or zinc mining.<sup>17</sup> Two U.S. mines reopened in the second half of 1986, including Bingham Canyon in Utah and the Continental Mine in Butte, Montana. Earlier that year, things had not been so optimistic when inspiration reduced production by 40 percent and laid off 300 employees.

The improved domestic position resulted from a variety of efforts made by the domestic industry to enhance its competitiveness, including lower labor, energy, and transportation costs; capital investments in plant and equipment; and changes in mining plans (see ch. 10). The impact of these efforts is evidenced by the almost 40 percent increase in productivity in domestic copper

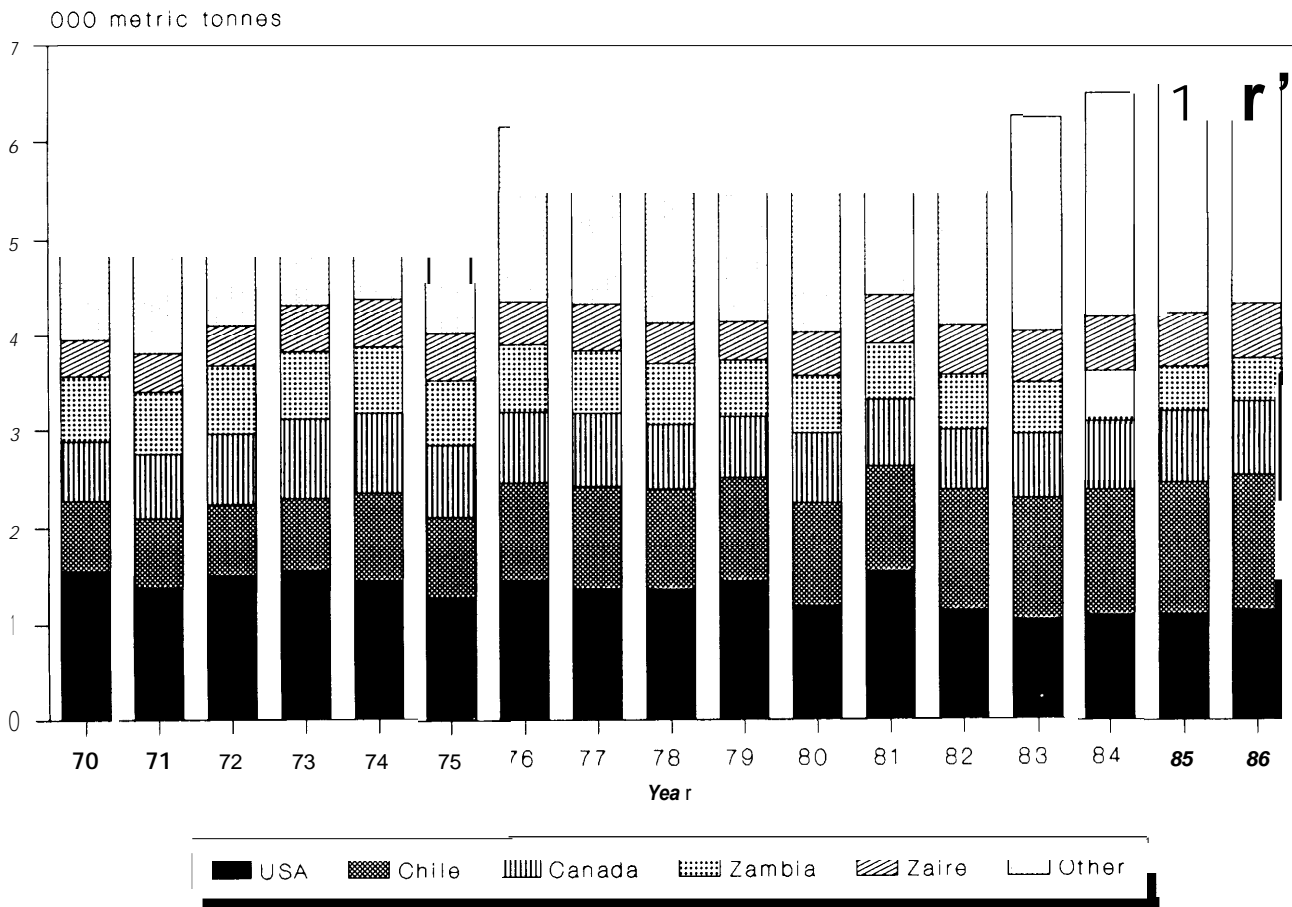
<sup>17</sup>Ibid.

**Figure 4-3.-Copper Mine Production in the Market Economy Countries (1986) (1000 metric tonnes)**



SOURCE U S Bureau of Mines data

Figure 4-4.-Trends in Mine Production, 1970-86



SOURCE: U S Bureau of Mines data

mining between 1980 and 1984, shown in figure 4-5.

Canada maintained its position as the third largest copper producer in 1986 with output of 768,200 tonnes (1.6 percent). A strike during most of November and December at Noranda's Home smelter, which processes ores from several small mines, resulted in slightly reduced aggregate mine production. Three Canadian properties-Highmont, Lornex and Valley-were consolidated during the year and an increase in their total output is expected. Deepening of the Ruttan Mine also increased its output. '8

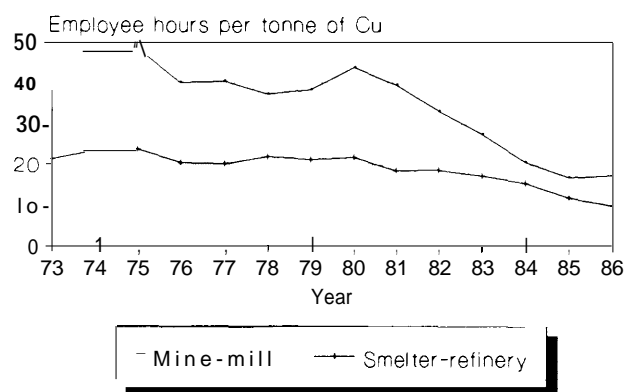
1 Blbici,

Zaire, the fourth largest copper producing country, mined 563,000 tonnes in 1986. The State-owned La Generale des Carrieres et des Mines du Zaire (Gecamines) has a 5-year investment program to rehabilitate its industry. The program focuses on maintaining mine production capacity while raising productivity and reducing costs, primarily through worker training, revised mining plans, and capital invest merit. '9

The Zambia Consolidated Copper Mines Ltd. (ZCCM), which accounted for all of Zambia's mine, smelter, and refinery production, mined 450,000 tonnes of copper in 1986. As in Zaire,

1 Ylbid,

**Figure 4-5.-Productivity in the U.S.  
Copper Industry: 1973-86**



SOURCE U S Bureau of Mines

ZCCM announced a 5-year reorganization plan to reverse deterioration of its copper operations. The plan included near-term closure of 50,000 tonnes annual mine capacity as soon as reserves already drilled become exhausted. The Kansanshi and Chambishi copper mines, and one shaft of the Konkola mine closed by mid-1986. The plan reflects a strategy to reduce excess smelter and refinery capacities vis-a-vis mine production and to increase SX-EW production. In total, **20,000 workers** will be affected—3,000 in 1986 alone.<sup>20</sup>

Despite labor problems, Peruvian mine production was up slightly in 1986 to 397,400 tonnes. Three State-owned mining companies (Centromin Peru, Minero Peru, and Tintaya) and one privately-owned company (SPCC) accounted for about 96 percent of Peru's copper production. The two largest companies—SPCC and Centromin—experienced a combined reduction in mine output of around 19 percent.<sup>21</sup>

Approximately thirty other market economy countries reported mine production in 1986, including copper produced as a byproduct of other mining activities. These countries accounted for 29 percent of the NSW total with combined production equal to 1.9 **million tonnes**.

<sup>20</sup> Ibid.  
<sup>21</sup> Ibid.

## Smelting

Western world primary smelter production was nearly 6 million tonnes in 1986—a 13 percent increase since 1970. Total NSW smelter production (primary and secondary) was 6.8 million tonnes. **While the United States still holds the lead in total smelting (primary and secondary), domestic primary output has dropped almost 40 percent relative to 1970. Chilean primary smelter output has increased consistently in the last two decades, passing the United States in 1982 to become the world leader (see figure 4-6).**

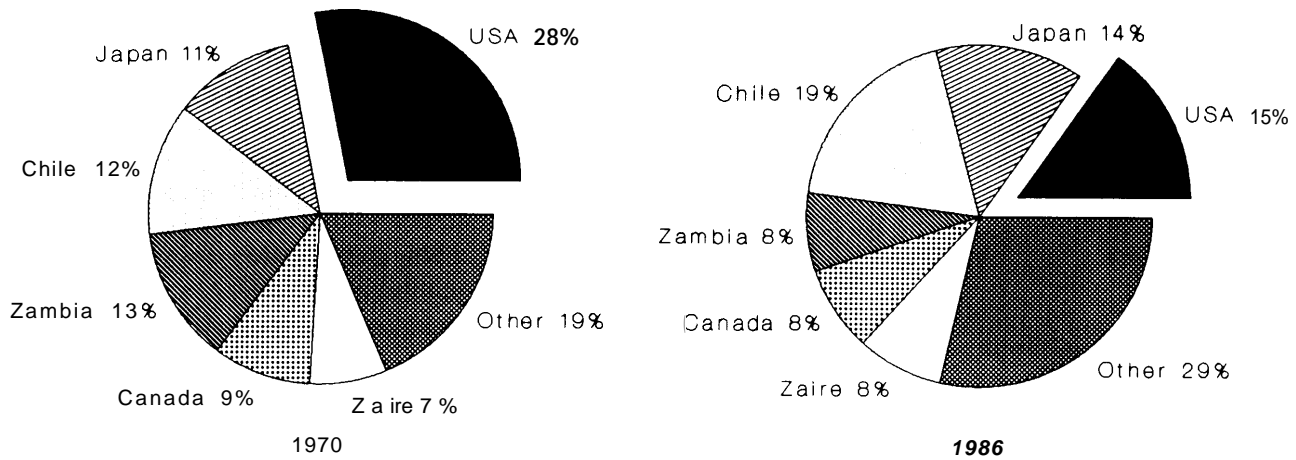
Domestic smelters produced nearly 1.2 **million tonnes (17.5 percent of the NSW total)**, including 908,100 tonnes of copper from domestic and imported ores and concentrates and 287,800 tonnes from scrap materials. Nine primary smelters and seven secondary smelters operated during 1986, with one of each closing permanently in 1987. The United States imported almost 5,000 tonnes of copper contained in concentrates, versus 174,348 tonnes exported.<sup>22</sup>

The scheduled reopening of two domestic smelters and the modernization of a third showed evidence of a recovery in the U.S. primary copper smelting industry in 1986. The White Pine smelter in Michigan reopened in 1986 and the Garfield smelter in Utah restarted in 1987. Magma Copper is installing an Outokumpu flash furnace at its San Manuel, Arizona smelter. When it reopens late in 1988, the smelter will be the largest single-furnace smelter in the world, processing about 2,700 tonnes of concentrates daily.

Phelps Dodge's Douglas, Arizona, smelter was permanently closed in January 1987 as part of an agreement reached between the company, the U.S. Environmental Protection Agency, and the State of Arizona. The Douglas smelter was built in 1904, and PD would have had to completely rebuild it to bring it into compliance with air quality standards. Phelps Dodge partially compensated for the loss of the Douglas smelting capacity by buying Kennecott's two-thirds share in the Chino, New Mexico mine and smelter in 1986.

<sup>22</sup> Ibid.

**Figure 4-6.-Primary Smelter Production:  
The U.S. Share Has Declined**



SOURCE: U.S. Bureau of Mines data

Chile ranked second in smelting with reported output of 1.113 million tonnes (1 6.2 percent of NSW total), followed by Japan with 951,400 tonnes (1 3.9 percent). Zaire and Zambia are also major players in smelting, reporting outputs of 480,000 and 452,000 tonnes, respectively. Other top smelters included: Canada, 491,000 tonnes; Peru, 297,700 tonnes; Federal Republic of Germany, 246,000 tonnes; and Australia, 176,900 tonnes. The residual total of all other smaller producers amounted to 1.42 million tonnes, or 20.8 percent of total NSW smelter production (see figure 4-7).<sup>23</sup>

### Refining

Western world primary copper refineries produced 6.3 million tonnes in 1986—the strongest level since 1982 and a 2 percent increase over 1985. Western refineries also produced nearly 1.2 million tonnes from scrap. World primary refinery production has increased about 12 percent in the last 10 years, yet domestic production has dropped 23 percent during that time. The U.S. share of NSW primary refined copper production fell from almost 25 percent in 1976 to only about 17 percent in 1986. Chile has enjoyed the

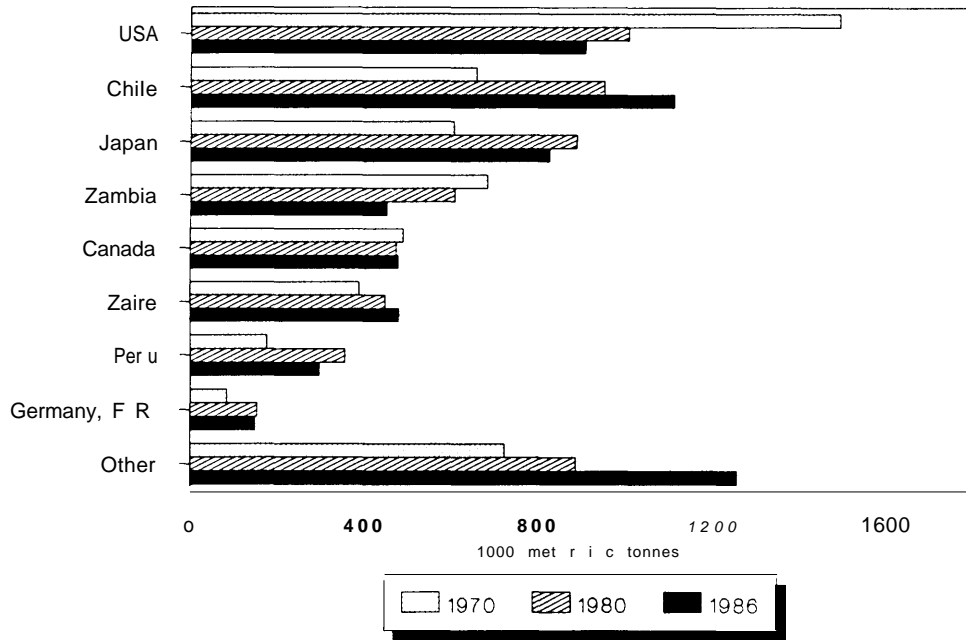
**largest growth in refined copper production, increasing 47 percent since 1976.**

Canada, Zambia, the Federal Republic of Germany, and Belgium are also significant producers of refined copper (see figure 4-8). Four of the smaller producers—the Philippines, South Korea, South Africa, and Brazil—have experienced dramatic increases in output. In 1976, aggregate primary production from these four countries was 126,500 tonnes, or 2.2 percent of the NSW total. By 1986, their combined primary refinery output had increased to 564,900 tonnes, or 8.9 percent of the NSW total.

Total domestic refined copper production rose 3 percent in 1986 to 1.48 million tonnes, including 406,000 tonnes from secondary sources (smelter and refinery scrap). Primary production was 1.07 million tonnes—a 1.5 percent increase over 1985. Virtually all of that increase was attributable to electrowon copper. Primary sources included around 5,000 tonnes imported concentrates and 35,000 tonnes imported blister and anode copper (see figure 4-9). Twenty-four domestic refineries operated during 1986, including 8 electrolytic, 10 electrowinning, and 9 fire-refining facilities (some refineries had more than one type of facility).

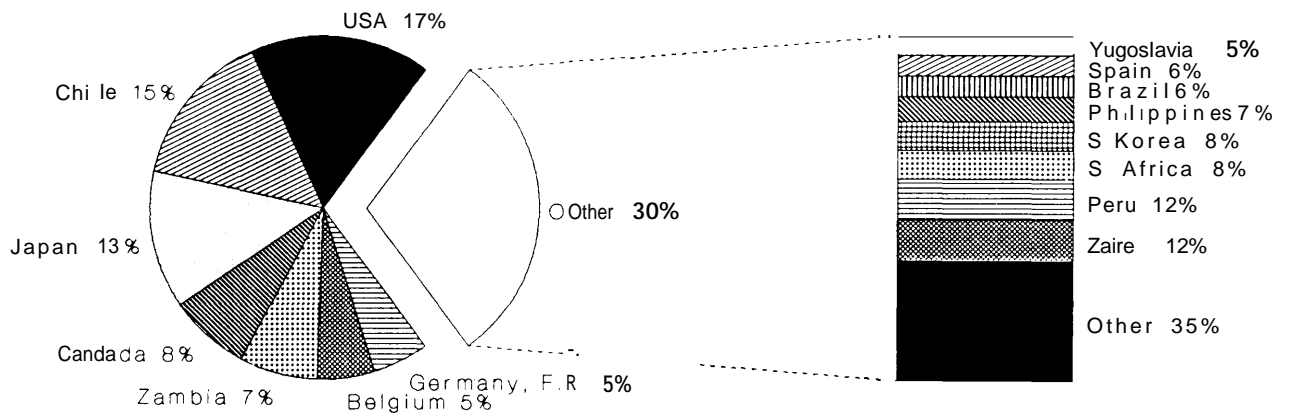
<sup>23</sup>Ibid.

**Figure 4-7.-Primary Smelter Production: 1970, 1980, 1986**



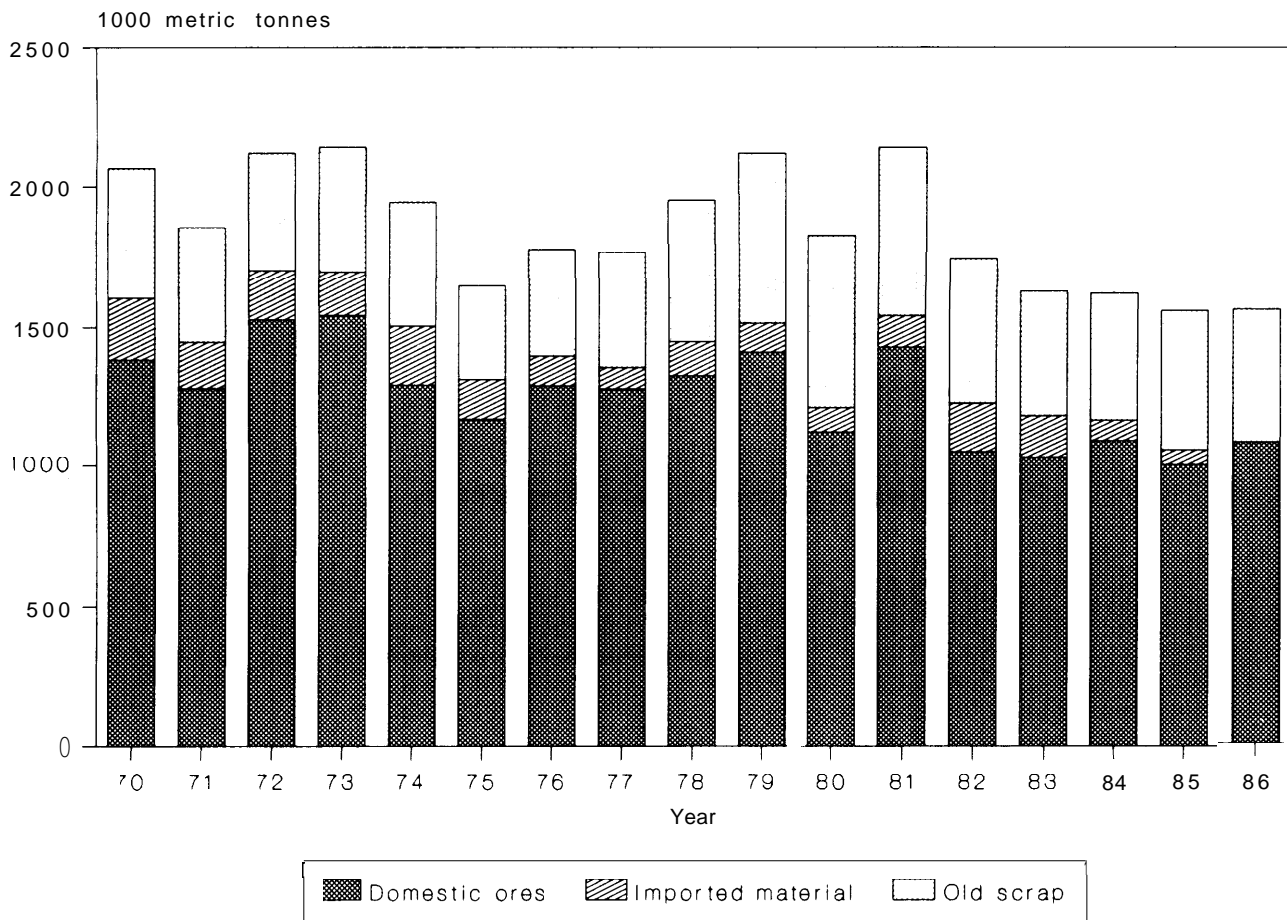
SOURCE U S Bureau of Mines data

**Figure 4-8.-Primary Refinery Production, 1986**



SOURCE U S Bureau of Mines data

Figure 4-9. -U.S. Production of Refined Copper by Source, 1970-86



NOTES: Old scrap only. 1986 data on imports not available

SOURCE: U.S. Bureau of Mines data.

Chile (935,000 tonnes) and Japan (827,700 tonnes) followed the United States, providing 14.7 and 13 percent of 1986 NSW refinery output, respectively. Thirty-one other countries reported production for the year, with the top 10 accounting for 80 percent of the total.

### Leaching and Solvent Extraction/Electrowinning

The current ability of the U.S. copper industry to produce copper at a price competitive in world markets is due in part to expanded use of solution mining and solvent extraction-electrowinning (SX-EW) technologies. As described

in chapter 6, **solution mining (or leaching)** uses chemical solutions or water to extract copper from ores. Solution mining can operate on vats or heaps of ore mined specifically for leaching, or the solutions can be applied to old mine workings and mine waste dumps. In the future, solution mining also will be used with undisturbed ore bodies. After leaching, the copper is either precipitated out of the solution, or the copper-laden solution goes through solvent extraction and electrowinning plants to produce cathodes. Production of copper cathodes using these techniques is far less complicated than conventional mining/milling/ smelting, and can cost less than 30 cents/lb for old workings and waste dumps.





Photo credit' Jenifer Robison

Sprinklers applying leach solution to mine waste dumps. Copper produced by leaching accounted for almost 19 percent of U.S. mine production in 1986.

Leaching/SX-EW of oxide and oxidized sulfide ores is very attractive in today's competitive copper markets because the technology has low capital costs and can be amortized rapidly compared to conventional mining, milling, and smelting. It can be built quickly, is flexible in its applications, and can be run practically at any scale; it has low operating costs, including energy use and environmental control requirements; and it requires minimal supervision compared to conventional copper production.<sup>24</sup>

As a result, the number of ongoing and planned SX-EW projects in the United States and other major copper producing countries have increased significantly since 1980 as part of copper com -

**panics' strategies to reduce costs (see box 4-A). In 1986, the United States had around 263,000 tonnes of SX-EW capacity. Another 186,500 tonnes are planned, 145,500 by 1990 (see table 4-2).**

**U.S. mines leached ore with a recoverable copper content of around almost 215,000 tonnes (including dump leaching) in 1986.** Ten electrowinning plants operated in the United States in 1986, producing around 125,400 tonnes of copper (around 12 percent of U.S. primary refinery production).<sup>25 26</sup>

At least five other Western countries currently produce copper through leaching/SX-EW: Can-

<sup>24</sup>United Nations Industrial Development organization (UNIDO), *Technological Alternatives for Copper, Lead, Zinc and Tin in Developing Countries*, report prepared for the First Consultation on the Non-ferrous Metals Industry, Budapest, Hungary, July 1987.

<sup>25</sup>Jolly and Edelstein, supra note 16.

<sup>26</sup>It should be noted that total electrowinning production reported before 1986 included AMAX's Braithwaite, Louisiana, plant, which processed imported copper (nickel matte).

#### Box 4-A. —Phelps Dodge and SX-EW Processing

**Phelps Dodge (PD)**, the nation's largest copper producer, has found the SX-EW facilities at its Tyrone operation to be a major cost-cutter. In 1984, this plant produced around 10,300 tonnes of copper at a total unit cost, including interest and depreciation, of less than 30 cents/lb.<sup>1</sup> Leaching plus SX-EW reduced overall Tyrone production costs as much as 11 cents/lb between 1980 and 1985.<sup>2</sup> The process was so successful that PD expanded the Tyrone electrowinning plant, increasing its output to about 32,000 tonnes in 1986. Further expansion to a total capacity of 50,000 tonnes/yr is scheduled for 1988 to 1989.<sup>3</sup>

To further benefit from this strategy, PD is adding two other SX-EW plants—at Morenci and Chino. These will require a capital outlay of \$130 million, with approximately the same cost of production as at Tyrone. The 45,000 tonne/yr SX-EW plant at Morenci began operation in 1987; expansion to a total capacity of about 68,000 tonnes/yr is expected within the next few years. A 40,000 tonne/yr plant at Chino is expected to come on line in 1988.<sup>4</sup>

Phelps Dodge also is evaluating a recently explored ore body near Bisbee, Arizona, for its leaching and SX-EW processing potential. Preliminary drilling results indicate 155 million tonnes of 0.5 percent copper ore amenable to SX-EW. If these results hold true in further exploration, annual production is estimated to be around 40,000 tonnes/yr. <sup>5</sup>

These facilities, plus increased smelter production at Chino, should compensate for the approaching exhaustion of sulfide reserves at Tyrone. The share of electrowon copper produced by PD using leaching plus SX-EW is expected to rise from its 1986 level of 8.7 percent to 33 percent or more by 1989.<sup>6</sup>

<sup>1</sup>G. Robert Durham, "Remarks," speech given at the Northwest Mining Association, 92nd Annual Meeting, Spokane, Washington, December 4, 1986.

<sup>2</sup>United Nations Industrial Development Organization (UNIDO), *Technological Alternatives for Copper, Lead, Zinc and Tin in Developing Countries*, report prepared for the First Consultation on the Non-ferrous Metals Industry, Budapest, Hungary, July 1987.

<sup>3</sup>"Phelps Dodge Has Something to Smile About," *Engineering and Mining Journal*, August 1987.

<sup>4</sup>ibid.

<sup>5</sup>"North American SX-EW Copper," *Mine Development B/monthly*, vol. V, No. 2, Oct. 31, 1987.

<sup>6</sup>*Engineering and Mining Journal*, supra note 3.

ada (5,000 tonnes capacity), Chile (90,000 tonnes capacity), Peru (35,000 tonnes), Mexico (14,000), and Zambia (475,000). Near-term expansions have been announced at Chuquicamata in Chile, and Cananea in Mexico. Reported electrowon copper production in these countries in 1986 was over 130,000 tonnes.

#### Future Supply Considerations

Overcapacity and low copper prices have existed in the copper industry throughout most of the 1980s. Ambitious development plans prevalent in the 1970s have largely been replaced with strategies aimed at reducing costs at existing facilities. Most recent capacity increases have been new or expanded SX-EW facilities. With the exception of small, relatively high-grade deposits, this trend is expected to continue until in situ solution mining techniques become commercial. Then U.S. producers will begin to ex-

loit large oxide deposits, again with SX-EW technology,

Planned expansions of traditional mining capacity primarily are overseas, where labor costs are lower, ore grades higher, and environmental regulations less stringent. The Ok Tedi Mine in New Guinea began producing copper in 1987, with long range plans for a capacity of 600,000 to 700,000 tonnes/yr of concentrates. However, continuing financing and operational difficulties make the amount produced and the schedule uncertain. During 1988, the Neves Corvo mine in Portugal is projected to come on line with an annual capacity of about 100,000 tonnes of copper in concentrates, and the new Australian operation, Olympic Dam, will add an additional **55,000 tonnes**. The Escondida mine in Chile is tentatively planned to come on line in the early 1990s (perhaps as early as 1991), with Utah international holding a majority share. Initial

Table 4-2.—Solvent Extraction/Electrowinning Capacity

Project	Location	Existing capacity <sup>a</sup> (tonnes/yr)	Operating status	Planned capacity addition (tonnes/yr)	Estimated cost (\$/lb)	Comments
Bisbee . . . . .	Arizona	—		41,000	\$0.50	Drilling shows 155 million tonnes 0.5% Cu amenable to Sx
Cyprus Bagdad . . . . .	Arizona	6,800	Open		0.45	Cost includes mining; without mining, cost is 29 cents/lb
Cyprus Casa Grande. . . . .	Arizona	18,000	Open	22,000	<0.40	Purchased from Noranda in 1987; ore leached in situ
Cyprus Johnson . . . . .	Arizona	4,300	Closed		0.50	Closed permanently at end of 1986
Inspiration . . . . .	Arizona	45,000	Open	13,000	<0.60	All mined output for 1986-87 processed by leaching
Miami . . . . .	Arizona	6,000	Open		0.60	
Morenci . . . . .	Arizona	45,000	Open	23,000	0.25	Date of expansion uncertain
Pinto Valley . . . . .	Arizona	8,000	Open	12,000	0.37	Leaching low-grade sulfide ore; leaching of tailings to begin in 1989
Ray . . . . .	Arizona	36,000	Open		0.50	Leaching 1.25% silicate ore
San Manuel . . . . .	Arizona	22,500	Open	22,500	0.45	Planned in situ leaching and capacity expansion to begin 1988
Twin Buttes . . . . .	Arizona	30,000	Closed		0.50	Mine leased by Cyprus in 1988; SX-EW status uncertain
Battle Mountain. , . . . .	Nevada	6,500	Closed		0.50	
Chino . . . . .	New Mexico	—		41,000	<0.30	Startup expected late 1988
Tyrone . . . . .	New Mexico	35,000	Open	15,000	<0.30	Expansion expected 1988-89
Gibraltar . . . . .	BC, Canada	5,000	Open		0.35	Opened in 1986; first SX-EW in Canada
Chuquicamata . . . . .	Chile	50,000	Open	40,000	0.45	Current expansion planned for 1990; long-term plans for 250,000 tonnes total
El Teniente. . . . .	Chile	5,000	Open		<0.30	
Lo Aguirre . . . . .	Chile	14,000	Open		0.35	
Las Cascadas . . . . .	Chile	20,000	Open		0.60	
Cananea . . . . .	Mexico	14,000	Open	20,000	NA	Startup expected late 1988; leaching low-grade (0.15-0.45% Cu) dumps
Cerro Verde . . . . .	Peru	35,000	Open		0.40	
Nkana . . . . .	Zambia	125,000	Open		0.35	
Nchanaa . . . . .	Zambia	350,000	Open		NA	Must be re-refined

NA = not available.  
<sup>a</sup>Annual production in any year may be less

SOURCE: Office of Technology Assessment, from data published by the U.S. Bureau of Mines, *Mine Development Bimonthly*, and the United Nations Industrial Development Organization

planned output is 200,000 tonnes/yr, increasing to 300,000 tonnes/yr. Other new projects include the Salobo copper-gold deposit in Brazil (10,000 tonnes/yr); the Maria mine in Sonora, Mexico; and the Ansil property in Canada (30,000 tonnes/yr).<sup>27</sup>

These expansions will be balanced to some extent by cutbacks in other regions. Mines that are nearing the exhaustion of their resources include Tyrone in New Mexico and Prieska in South Africa. Operational problems (including disrup-

<sup>27</sup>—Simon D. Strauss, "Copper: Prices Surged Unexpectedly," *Engineering and Mining Journal*, April 1, 1988

tions due to weather and labor) continue to trouble Chile, Peru, and several smaller producers. Mine operation and development in Zambia and Zaire have suffered from inadequate capital investment and now are having trouble attracting skilled employees due to the unstable political environment and the threat of AIDS; their future output is thus uncertain. Finally, efforts to reduce production costs in recent years, including higher cut-off grades, lower stripping ratios, and abandoning low-grade sections of underground mines, have reduced the life of some mines.<sup>28</sup>

<sup>28</sup>bid.

## DEMAND

### Properties and Uses

Copper possesses valuable physical, chemical, and mechanical properties that make the metal and its alloys<sup>29</sup> useful in nearly every sector of the economy. Copper exhibits very high electrical conductivity (second only to silver in volumetric conductivity, and to aluminum in mass conductivity), as well as high thermal conductivity. It also is nonmagnetic and is among the strongest and most durable metals while still being highly malleable. Moreover, copper is especially resistant to corrosion and fatigue, and inhibits the attachment of organisms such as algae, mussels, and slime to submerged structures (biofouling).

**Demand for copper in individual sectors of the economy varies with economic conditions and consumer demand for products (e.g., electricity demand growth, housing starts, automobile purchases), as well as with the price and availability of materials that might be used instead of copper.** Over the last two decades there has been a significant increase in copper use in the electrical and electronics industries due to the growth of electronic devices in computers and telecommunications, consumer products, and automobiles. The combination of all electrical/electronics uses accounted for an average of **50 percent of the semifabricator market during the 1960s, but had risen to around 70 percent of apparent domestic consumption by 1986.30**

**Construction industry demand ranked second in 1986, with 15 percent.** The major non-electrical uses there included plumbing and heating materials, air conditioning and commercial refrigeration equipment, and roof and wall cladding. Next was the industrial machinery and equipment industry, with 6 percent of total domestic demand. In-plant equipment and industrial valves and fittings are the major non-electrical uses in this market.<sup>31</sup>

The diversity of uses for copper and its alloys is evidenced in the range of consumer goods and general products associated with these materials. Consumer goods containing copper metal or its alloys vary from appliances and cooking utensils to fasteners to jewelry and objets d'art. Other miscellaneous uses include coinage, chemicals, pharmaceuticals, and furnishings. Consumer goods and miscellaneous applications (including non-electrical military uses) represented 5 percent of 1986 total domestic demand for copper mill products.<sup>32</sup>

Virtually all modes of transportation contain copper products. Radiators, bearings, and brake linings are only a few of the many automobile parts made with copper or copper alloys. Resistance to corrosion and biofouling have made copper products invaluable in a number of applications associated with marine transportation, including propeller shafts, steam and water lines, and cladding for hulls. The railroad, aircraft and aerospace, truck; and bus industries also make widespread use of copper products. In total, the transportation industry accounted for the remaining 4 percent of domestic demand for copper mill products in 1986.<sup>33</sup>

The shares of demand for these end-use sectors change substantially when the electrical and electronics applications are distributed among them (e.g., the majority of electrical wiring is included in construction, and copper wire in cars and trucks is included in the transportation sector rather than in electrical/electronics uses; see figure 4-1 O). Again, significant variance over time also is evident. Figure 4-11 compares U.S. copper demand by sector for 3 years: 1979, a year of record consumption; 1982, a recession year; and 1986, a year of recovery.

Using these disaggregate data, the major domestic market for copper in 1986 was the construction industry, accounting for around 41 percent of total demand. The second largest market—23 percent—was in the electrical industry for cable, electric motors, power generators, fans,

<sup>29</sup>Including brass, bronze, copper nickel, copper-nickel-zinc alloy and leaded copper; see ch. 1,

<sup>30</sup>Jolly and Edelstein, *supra* note 16.

<sup>31</sup>*Ibid.*

<sup>32</sup>*Ibid.*

<sup>33</sup>*Ibid.*



Photo credit: Jenifer Robison

Architectural uses of copper have seen a renaissance in the 1980s, in part due to the low price and in part to new coatings that greatly retard formation of the patina caused by exposure to the elements. Here, a copper strip is placed above reflective glass windows.

blowers, lighting, industrial controls, transformers, bus bars, and switchgears. Next was the industrial machinery and equipment industry, with 14 percent of total domestic demand, followed by transportation (almost 13 percent), consumer goods and miscellaneous applications (9 percent).<sup>34</sup>

Copper is a significant critical metal. While only 1 percent of U.S. copper consumption goes to ordnance, per se, copper wire is a critical component of all electrical and electronics needs, including command-communication-control-intelligence (C<sup>3</sup>I) systems. Military aircraft and vehicles, and tactical, strategic, and advanced weaponry systems also use significant quantities

<sup>34</sup>Copper Development Association, "Copper and Copper Alloy Mill Products to U.S. Markets— 1986," *CDA Market Data*, May 10, 1987.

of copper. Military demand for electronic equipment and computer components is expanding. Finally, the vast industrial base that supports the national defense requires machinery and goods containing copper.<sup>35</sup> For example, copper demand doubled within the first year of WWII, and increased 25 percent within the first year of the Vietnam War.

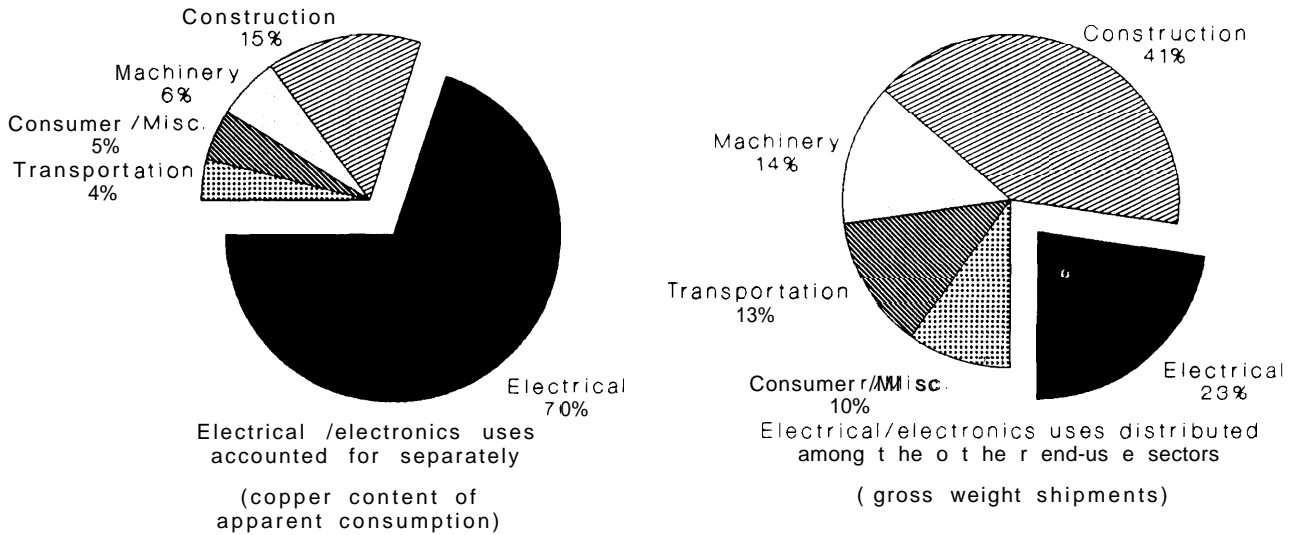
### World Consumption

Total NSW demand for refined copper<sup>36</sup> was 7.67 million tonnes in 1986. **The United States is the largest user of refined copper**, with con-

<sup>35</sup>Louis Sousa, *The U.S. Copper Industry, Problems, Issues, and Outlook* (Washington, DC: U.S. Department of the Interior, Bureau of Mines, October 1981).

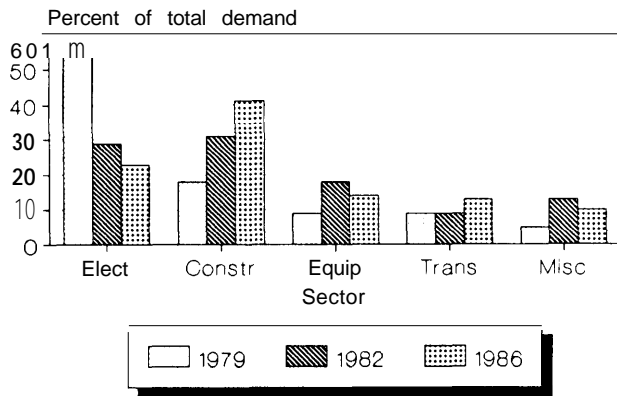
<sup>36</sup>Consumption of unwrought refined copper, whether refined from primary or secondary materials, except the direct use of copper in scrap.

**Figure 4-10.-Distribution of Electrical and Electronics Uses in Copper Demand**



SOURCE: US. Bureau of Mines, Copper Development Association

**Figure 4-11. -U.S. Copper Demand by Sector: 1979, 1982, 1986**



NOTE: In this figure, demand is measured by the gross weight of shipments  
 SOURCE: US Bureau of Mines data.

sumption of 2.1 million tonnes. Demand in Japan, the second largest consumer, was around 1.2 million tonnes. **European consumption of refined copper was 2.8 million tonnes in 1986, with five countries—the Federal Republic of Germany, France, Italy, the United Kingdom and Belgium—accounting for almost 80 percent of European de-**

mand. Although Chile, Zaire, and Zambia are major copper producing countries, their consumption of the metal is low. Combined demand for the three of 45,000 tonnes in 1986 represented less than 1 percent of NSW refined copper demand.

Remelting of unrefined copper scrap by semi-fabricators amounted to 2.5 million tonnes in 1986. Brass mills and other fabricators in the United States and Japan were the primary consumers of scrap. Domestic consumption of copper scrap by brass mills declined 8 percent in 1986 due to supply shortages resulting from increased scrap exports and narrow profit margins for scrap dealers. At some times, #1 scrap was actually more expensive than refined copper. Because of the scrap shortage, primary refined copper consumption at brass mills increased 26 percent during 1986.<sup>37</sup>

<sup>37</sup>Jolly and Edelstein, *supra* note 16.

## Technology and Future Demand<sup>38</sup>

In the last forty years, transistors and subsequent microelectronic technologies have had far-reaching effects. A host of derivative technologies **have evolved**, such as advanced global communications and the array of services and products introduced by the computer. The copper industry experienced both positive and negative impacts from this transition. The electronics industry provided a sizable market for copper, representing nearly a quarter of domestic consumption in 1986. However, the evolution of microelectronics also brought more efficient technologies that decreased the intensity of copper use in some applications, including reducing wire size and replacing the metal with optical fibers. In electronics, high-temperature fabrication and performance needs also have led to a shift from pure copper to specialty alloys such as beryllium copper. Copper alloy consumption in electronics has grown fivefold since 1975.<sup>39</sup>

Other recent technological developments having a negative impact on copper demand include low-cost brazing methods, which allowed aluminum to replace copper in large portions of the automotive radiator market; temperature-resistant plastics that have replaced copper in many plumbing tube applications; and aluminum alloys that made aluminum wire and cable more competitive with their copper counterparts.

In balance, though, **domestic copper consumption has grown at a modest rate of about 2 percent annually since 1970. over the same period, consumption in the rest of the market economy countries has averaged 3 percent annual growth, for an NSW average of around 2.4 percent.**

Predicting future growth is difficult for a number of reasons. First, as noted above, **technological changes have both positive and negative impacts on copper demand.** This is evident even in individual products. For example, the Copper Development Association estimates that in-

creased electric and electronic applications in automobiles since 1980 have more than offset reduced copper use due to downsizing of cars and the one-third market share currently enjoyed by aluminum radiators. A passenger car contained around 41 pounds of copper in 1975, 36 pounds in 1980, and 48 pounds in 1986. This increase is projected to continue through at least 1990.<sup>40</sup>

**A second major difficulty in predicting short-term future demand is the inability to foresee general economic conditions.** For instance, a 1980 Resources for the Future study suggested that demand surges between 1980 and 1985 would lead to copper shortages.<sup>41</sup> Instead, there was a major recession accompanied by capacity increases and substantial oversupply. Although domestic demand grew at an average of 2 percent during 1970-1986, those years saw two recessions, two periods of double-digit growth, and several unusual market shifts (e. g., the rise of personal computers and the effects of the oil crisis).

**Even more difficult to predict are demand surges caused by new technologies.** Much of the technological research affecting copper consumption goes on outside the industry that produces the metal, making forecasting even more difficult. Estimates for the next 10 years made by the Copper Development Association include an enormous short-term growth in demand for consumer electronics, telecommunications, information services, and copper-dependent electronics such as heat pumps and devices in automobiles.

Copper-based marine antifouling paints will increase rapidly through the early 1990s. Existing paints use tributyltin (TBT), which is being banned for environmental reasons. Copper paints may only provide one year's protection, compared to 3-7 years for TBT paints. Thus they will have to be applied more often. Over the long term, cop-

<sup>38</sup>Unless otherwise noted, the information in this section is from a presentation given by William Dresher, International Copper Research Association, at Copper 87, in Chicago, November 1987.

<sup>39</sup>Jolly and Edelstein, supra note 16.

<sup>40</sup>Copper Development Association, "Use in Autos Rises as Cars Increase Electrical/Electronic Systems," *Copper Topics*, No. 61, Winter 1987.

<sup>41</sup>Leonard L. Fischman, *World Mineral Trends and U.S. Supply Problems* (Washington, DC: Resources for the Future, Research Paper R-20, 1980).

per paints probably will be replaced by non-stick coatings similar to Teflon.<sup>42</sup>

Further down the road—perhaps 10 to 20 years—the effects of new technologies, including superconductors (which use copper), might vary from a major expansion in copper-consuming applications to drastic reductions from substitution and obsolescence. Technological forecasting becomes completely opaque when it comes to radically new inventions, however. Something to

<sup>42</sup>Hugh McKellar, "Good Substitutes Will Lessen Impact of Ban on TBT Paints," *National Fisherman*, December 1987, p. 5.

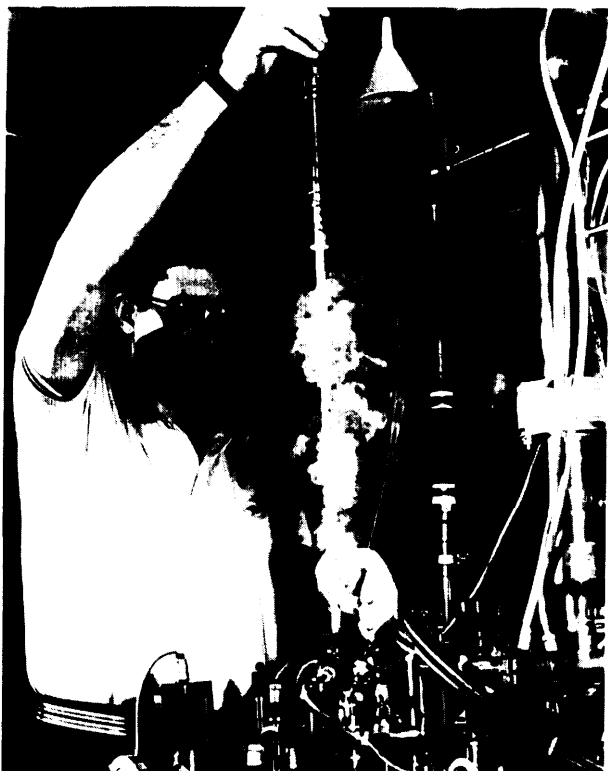


Photo credit: Argonne National Laboratory

Superconducting wire, ready for testing.

tally unforeseen could be invented tomorrow that dramatically increases or decreases the demand for copper.

**Of known technologies, superconducting materials and their applications probably have the greatest potential to impact future copper demand.** A possibility exists for tremendous growth in copper usage arising from several feasible developments in superconductor technologies, including: 1) the need for copper oxide in all high temperature superconductors as part of the chemical makeup; 2) the use of a predominantly high purity, oxygen-free copper stabilizer in state-of-the-art superconductors; 3) the development of "electricity pipelines" where electrical power would be transmitted in copper-clad superconductors cooled by liquid nitrogen;<sup>43</sup> and 4) a significant decrease in the cost of generating and transmitting electricity could increase electricity consumption and the demand for copper in wire and cable applications would grow as well.

While the potential for expansion in copper usage exists with the introduction of superconductor technologies, negative impacts also could be realized. The development of a superconductor requiring no coolant or stabilizer could be devastating, possibly replacing copper in all major electrical conduction applications. In addition, superconducting electrical generators have several advantages over copper-wound generators and require significantly less copper per megawatt. The new superconductor generators are especially useful where space is a consideration and are already replacing conventional **wire-wound generators in icebreakers and submarines.**

<sup>43</sup>Only a few "electricity pipelines" would be needed to service an entire continent. However, aluminum would be displaced from high voltage transmission lines.

## TRADE

Until the 1960s, most major copper operations were integrated in the sense that ore was mined, milled, and smelted within the same region—often at the same site. Many operations were further integrated to include refineries and wire

mills; in other cases, blister copper or anodes were shipped to refineries located closer to fabricators. This pattern evolved in part due to the transportation costs for copper contained in concentrates (20-30 percent Cu) **versus copper in blis-**



ter (98.5 percent) and anodes (99.5 percent). Nearly all trade occurred in the form of refined copper. As a result, much of the value added accrued to the country or region where the ore was mined, or at least to the mining company.

In the early 1960s, the rapid growth of Japan and **West** Germany, both deficient in copper resources, greatly increased the proportion of **copper trade in concentrates**. As part of their raw materials strategies for postwar industrialization, these countries built smelters at home, financed mine development abroad, and arranged long-term contracts for trade between the two.<sup>44</sup> The trend toward increased trade in concentrates continued in the 1970s and 1980s, as **financing and operating smelters became increasingly difficult, and as the Clean Air Act compliance deadlines neared for U.S. smelters. Over the last 20-25 years, many major new mines developed around the world were not paired with local smelters.**

In Japan, this strategy was based on the reasoning that, by importing copper concentrate and smelting and refining it themselves, they could gain the value added in processing. Over time, increased Japanese smelter capacity would encourage the development of new copper mines in the Philippines, Papua New Guinea, and elsewhere around the Pacific Rim. This would mean security of concentrate supply by making mines dependent on Japan to buy their concentrates.<sup>45</sup>

producing sulfuric acid from the smelters' sulfur dioxide-laden gases meant even more value added, as this byproduct could be sold profitably to the growing Japanese chemical industry.<sup>46</sup> Japanese smelters were also given an advantageous pricing system, whereby Japanese industries paid higher than world market prices for copper and sulfuric acid. This system was supported by high tariffs on refined copper and sulfuric acid, and essentially provided an indirect subsidy to the smelters. The smelting companies were then able

to offer foreign mines terms well below what it would cost to finance, build, and operate smelters and refineries.<sup>47</sup> These generous terms drew a great deal of concentrate to Japan, and have been controversial among U.S. smelting companies since the 1960s. Most recently, they came under fire during the tight concentrate market in the early to mid-1980s.

The world concentrate market has been characterized by an increasing group of players and supply shortages in the last few years. The demand for concentrates has risen as new and modernized smelters have come on line in Chile, the Philippines, and elsewhere. As a result, concentrate supplies available to Japan have declined. High energy costs and the increased valuation of the yen relative to the currencies of other smelting countries also reduced Japan's ability to compete for input for its smelters.

As a result, **Japan has moved to secure their supply of concentrates by investing directly in overseas mining capacity.** In the United States, Phelps Dodge (PD) sold a 15 percent interest in its Morenci properties (excluding the smelter but including SX/EW output) to a partnership subsidiary of Sumitomo Metal Mining Company and Sumitomo Corporation in 1986.<sup>48</sup> For PD, this sale provided much-needed cash flow, and reduced the operating imbalance that resulted from closure of the Morenci smelter.<sup>49</sup> For Japan, the sale was linked to an agreement that Sumitomo would obtain their share of the concentrate at cost.<sup>50</sup>

Japan's overall strategy dovetailed neatly with two other trends affecting smelter and refinery capacity in the United States. The first was simply the age of U.S. operations. Of the major copper-producing countries, the United States has the oldest industry, with many facilities operating since the early 1900s and before. Modernization often is not simply a matter of exchanging

<sup>44</sup>Some of the financing came from official government lending institutions such as the Export-Import Bank of Japan and the German Kreditanstalt für Wiederaufbau.

<sup>45</sup>"Asset Restructuring in the U.S. Copper Industry, Part I: U.S. Industry Responds to Dramatic Changes in World Role," *CRU Copper Studies*, vol. 14, No. 4, October 1986.

<sup>46</sup>Japan also produces elemental sulfur and gypsum with the sulfur dioxide (see ch. 8). They export both sulfuric acid and sulfur.

<sup>47</sup>*CRU Copper Studies*, supra note 45.

<sup>48</sup>Previously, Kennecott had sold a one-third interest in all of the output of Chino Mines to MC Minerals, a joint venture between Mitsubishi Corp. and Mitsubishi Metal Corp. PD purchased the remaining two-thirds from Kennecott in 1986.

<sup>49</sup>G. Robert Durham, "Remarks," speech given at the Northwest Mining Association, 92nd Annual Meeting, Spokane, Washington, Dec. 4, 1986.

<sup>50</sup>*CRU Copper Studies*, supra note 45.

ing outdated equipment, but replacing the whole plant, and the cost frequently is prohibitive. Thus, in the mid-1980s, PD closed their 100-year old refinery at Laurel Hill, New Jersey. The second, and more significant, trend was the combination of slow demand growth, smelter age, and Clean Air Act deadlines for smelter sulfur dioxide controls. Of 16 domestic copper smelters operating in the late 1970s, eight have been closed permanently.

The net result of all these events is that **the United States has reversed its early 1970s position as a net exporter of refined copper products and a net importer of concentrates, to become a net importer of refined products and a net exporter of concentrates** (see table 4-3). In 1986, the United States exported 15 percent of its concentrate production, while net import reliance for refined copper, measured as a percent of apparent consumption, was 24 percent. **Imports for consumption of refined copper reached a record high level in 1986, up 33 percent over 1985.** The ratio of net imports to consumption exceeded 20 percent for the third successive year.

**Canada and Chile were the principal sources of U.S. imports of refined products. Canadian copper accounted for almost 50 percent of the increase in total refined imports since 1985.** In terms of economic significance, the value of U.S. trade in copper concentrates has gone from roughly equivalent exports and imports in 1970, to net exports valued at \$184.6 million in 1986. Refined products have shifted from net exports of \$72.4 million in 1970, to net imports of \$540.6 million in 1986.<sup>51</sup>

<sup>51</sup>Jolly and Edelstein, supra note 16.

While the balance of mining/smelting and trade probably has shifted in the United States more than in other major copper mining countries, trading patterns have changed worldwide. The following sections present data on exports and imports of copper concentrates, blister/anode, and refined products for the major producing and consuming countries.

While OTA is able to report quantities of exports and imports, despite our best efforts at sorting out the available data, it was not possible to determine which trade went where. No single U.S. or international organization tracks such interchanges unless they are reported by the countries involved. Discrepancies between exports claimed by mining country A destined for consuming country B, and imports reported by country B allegedly originating in country A, confound any attempts to map trade among mining, smelting/refining, and consuming countries.

**Trade in copper contained in manufactured goods (e.g., automobiles, television sets) is virtually impossible to determine, because it is not reported.** Moreover, the copper content of such goods varies among models and manufacturers, and over time, and thus is extremely difficult to calculate. This is part of a broader problem affecting the analysis of changes in materials intensity of goods and the balance of trade in raw materials. It could be alleviated by reporting requirements for the copper content of goods imported to (and exported from) the United States. Such reporting could, however, be quite burdensome and may mean disclosure of what is currently considered proprietary information for some products.

**Table 4-3.—U.S. Copper Trade, 1970 and 1986 (thousand tonnes and million nominal \$U.S.)**

Product	1970				1986			
	Exports		Imports		Exports		Imports	
	Tonnes	Value	Tonnes	Value	Tonnes	Value	Tonnes	Value
Concentrates <sup>a</sup> . . .	55.81	\$58.4	58.76	\$77.7	174.35	\$187.8	4.93	\$ 3.2
Blister <sup>b</sup> . . . . .	7.10	7.5	203.43	224.3	15.96	17.4	34.55	60.2
Refined . . . . .	200.64	221.6	119.85	149.2	12.45	136.4	501.98	677.0
Scrap <sup>c</sup> . . . . .	— <sup>d</sup>		2.09	2.0	134.30	123.1	27.22	31.6

<sup>a</sup>Includes matte

<sup>b</sup>F, 1988, exports include precipitate, Imports include anode.

<sup>c</sup>Unalloyed.

<sup>d</sup>Not available; probably 16,000 to 18,000 metric tonnes.

SOURCE: Office of Technology Assessment, from Bureau of Mines data.

## Concentrates

In 1986, 1.4 million tonnes of concentrates were exported from Western countries for processing elsewhere (see table 4-4). Canada was the largest exporter that year, shipping out 341,400 tonnes. Chile was second with exports totaling 281,300 tonnes, followed by Papua New Guinea and the United States with concentrate exports of 178,800 and 174,400 tonnes, respectively.

Japan was by far the largest recipient of trade in concentrates, importing 837,400 tonnes in 1986 (60 percent of all concentrates destined for market economy countries). In contrast, 1986 mine production in Japan was 35,000 tonnes—around 4 percent of smelter production. As noted previously, Japan is experiencing increasing competition for this low value added material, and their relative share of the market is expected to decline gradually. On a much smaller scale, twelve other countries imported concentrates in 1986.

## Blister and Anode

Eleven countries reported exports of blister and anode copper in 1986; eleven also reported imports (table 4-s). Five countries reported both imports and exports of these products (France, the Federal Republic of Germany, Italy, Spain, and the United States); all were net importers.<sup>52</sup>

Zaire and Chile were the largest exporters of blister and anode copper, providing around 60 percent of market economy country exports. Zaire exports about 50 percent of its total smelter output, while Chile exported almost 18 percent of its smelter production in 1986. Peru's shipping 94,700 tonnes blister and anode copper represented nearly one-third of its smelter production. The United States imported 46,300 tonnes of blister and anode copper in 1986, and exported 16,000 tonnes. Belgium, the United Kingdom, and the Federal Republic of Germany were the

<sup>52</sup>WBMS, supra note 5.

**Table 4-4.—1986 Concentrate Trade (1,000 metric tonnes)**

Importers		Exporters	
Japan .....	837.4	Canada .....	341.4
Germany, F.R. ....	161.3	Chile .....	281.3
South Korea .....	116.7	PNG .....	178.8
Spain .....	72.3	USA .....	174.4
Canada .....	70.7	Philippines .....	93.3
Taiwan ... , , .....	44.8 <sup>a</sup>	Mexico .....	90.0 <sup>a</sup>
Finland .....	43.2	Australia .....	72.9
Other .....	51.7	Other .....	173.6
Total .....	1,398.1	Total .....	1,405.7

<sup>a</sup>JanuaV to September.

SOURCE World Bureau of Metal Statistics data

**Table 4-5.—1986 Blister and Anode Copper Trade (1,000 metric tonnes)**

Importers		Exporters	
Belgium .....	240.0	Zaire .....	236.3 <sup>a</sup>
United Kingdom .....	79.5	Chile .....	199.4
Germany, F.R. ....	69.8	Peru .....	94.7
USA .....	46.3	Sweden .....	18.5
South Korea .....	34.6	USA .....	16.0
Japan .....	27.8	Finland .....	15.7
France .....	22.3	Germany, F.R. ....	14.0
Other .....	28.9	Other .....	12.9
Total .....	549.2	Total .....	607.5

<sup>a</sup>1985 figure

SOURCE World Bureau of Metal Statistics data

largest recipients of blister and anode copper with imports of 240,000, 79,500, and 69,800 tonnes, respectively.<sup>53</sup>

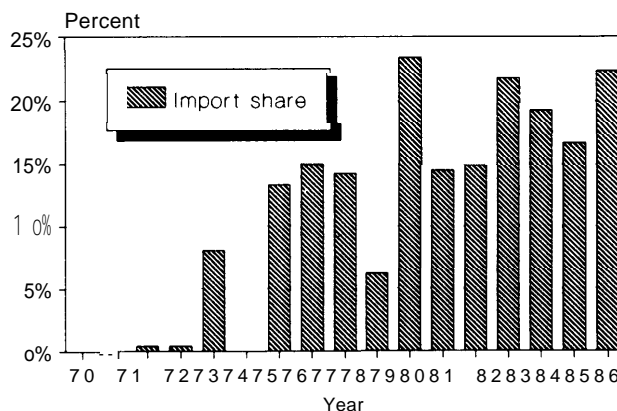
### Refined

More than 30 countries were involved in trade of refined copper in 1986. Major players in the market (table 4-6) included Chile and Zambia, with respective exports of 895,700 and 466,300 tonnes. The United States and the Federal Republic of Germany led imports with 491,700 and 447,900 tonnes, respectively.

**U.S. imports of refined copper rose to 24 percent of domestic consumption in 1986.** The United States has been a net importer of refined copper since 1976 and has experienced net exports in only 3 years since 1970. The penetration of imported refined copper products in the do-

mestic market in 1986 was only 1 percent lower than the 17-year high level of 1980 (see figure 4-12).

**Figure 4-12.-Refined Copper Imports as Percent of Domestic Refined Consumption**



NOTE The United States was a net exporter of refined copper in 1970, 1971, and 1975

SOURCE Copper Development Association

5)1 bid

**Table 4-6.—1986 Refined Copper Trade (1,000 metric tonnes)**

Importers		Exporters	
USA .....	491.7	Chile .....	895.7
Germany, F.R. ....	447.9	Zambia .....	466.3
Italy .....	349.1	Canada .....	304.8
France .....	334.5	Belgium .....	232.5
Japan .....	272.4	Peru .....	193.0
United Kingdom .....	263.5	Philippines .....	124.6
Belgium .....	215.2	South Africa .....	68.4
China .....	103.5 <sup>a</sup>	Germany, F.R. ....	67.8
Taiwan .....	84.7 <sup>b</sup>	Australia .....	66.8
South Korea .....	83.9	Spain .....	62.3
Other .....	292.8	Other .....	243.8
Total .....	2,939.2	Total .....	2,726.0

<sup>a</sup>January to September

<sup>b</sup>January to October

SOURCE: World Bureau of Metal Statistics data

## COPPER MARKETS IN CENTRALLY PLANNED COUNTRIES<sup>54</sup>

Under central planning, the State determines prices, the level of production, the amount of consumption, and the purposes for which minerals are used. The major priorities in mineral pol-

unless otherwise noted, the material in this section is from Simon D. Strauss, *Trouble in the Third Kingdom* (London: Mining Journal Books Ltd., 1986).

icy are first to attain maximum self-sufficiency in supply, and second to conserve scarce foreign exchange. If a mineral must be imported, the source is most likely to be another centrally-planned trading partner. Detailed official statistics of mineral production and consumption are not published by most centrally planned coun-

tries, including the Soviet Union and China. informed (but differing) estimates for the post-World War II period are available from the U.S. Bureau of Mines and the World Bureau of Metal Statistics (see table 4-7).

Soviet production of copper between the two world wars was small by world standards. Following World War II, production was expanded to reduce import dependency and rebuild the industrial base. Between 1950 and 1986, production of copper contained in ore increased from 218,000 tons to 620,000 tonnes, and the Soviets are now essentially self-sufficient in copper. In order to achieve self-sufficiency, however, the Soviets have had to develop copper deposits that would not be considered economically viable in market-economy countries. For example, a 1985 report of the Kazakhstan Academy of Science noted that "nationally ore containing 0.2 percent copper is now considered economic."

After centuries of orientation on agricultural rather than industrial production, the extent of China's mineral resources were largely unknown. Since 1949, efforts have been made to explore and map the country's minerals, but the full potential is far from being determined. Large low-grade copper deposits have been discovered that will require enormous investments if they are to become producers. However, this cost creates severe problems given the government policy to avoid incurring substantial external debt. Plans

for joint venture arrangements between the Chinese Government and foreign corporations are proceeding very slowly. With roughly 25 percent of the world's population, China accounted for only about 5 percent of the global consumption of most minerals—390,000 metric tons of copper in 1985.

The current copper producing status of the other centrally-planned countries is estimated to be as follows:

- Albania is self-sufficient;
- Bulgaria has export surpluses;
- Cuba has a modest output, exported as concentrate, but the mineral content of finished goods supplied by the Soviet Union and other countries is significant;
- Czechoslovakia is heavily industrialized but has a small non-fuel minerals industry, and is a net importer;
- The German Democratic Republic produces only a small fraction of its own needs;
- Hungary also is heavily import dependent;
- Korea D.P. R. is close to self-sufficiency;
- Poland is a large producer, with a well-established industry developed over the last 20 years with capital and technology from the market-economy countries, and substantial exports to Western Europe; and
- Romania has some production, but is a net importer.

**Table 4-7.—Copper Production in Centrally Planned Countries  
(1,000 metric tonnes)**

Country	1970 <sup>a</sup>		1978			1986		
	Mine	Smelter <sup>b</sup>	Mine	Smelter	Refinery <sup>c</sup>	Mine	Smelter <sup>d</sup>	Refinery <sup>e</sup>
Albania <sup>d</sup>	NA	5.6	11.5	9.5	7.0	17.6	13.7	11.7
Bulgaria	43.2	43.8	58.0	64.0	62.0	80.0	90.0	95.0
China	100.0	100.0	200.0	200.0	270.0	185.0	225.0 <sup>g</sup>	400.0
Cuba	3.0	—	2.8	—	—	3.3	—	—
Czechoslovakia	4.4	4.0	4.7	10.0	23.8	10.0	12.4	26.5
German D.R.	10.0	10.0	16.0	17.0 <sup>h</sup>	49.0	10.0	12.0 <sup>e</sup>	63.0
Hungary	1.0	1.0	0.5	0.3	13.1	—	0.1 <sup>i</sup>	12.8
Mongolia	NA	NA	4.0	—	—	128.0	—	—
North Korea	12.7	12.7	15.0	20.0	25.0	15.0	18.0	22.0
Poland	72.2	72.4	321.0	337.0	332.2	431.0	400.0	388.0 <sup>e</sup>
Romania	13.0	10.0	27.0	42.9	40.5	27.0	39.0	43.0
U.S.S.R.	572.7	572.7	865.0	955.0	980.0	620.0	915.0	965.0
Total	832.2	832.2	1,525.5	1,655.7	1,802.6	1,526.9	1,725.2	2,027.0

<sup>a</sup>Refinery data not available <sup>d</sup>Primary smelter and refinery Production.

<sup>b</sup>Primary only

<sup>c</sup>Primary and secondary unless noted otherwise

SOURCE U S Bureau of Mines data

<sup>e</sup>Primary

<sup>f</sup>Secondary only

**Part Three**

# **Resources and Technology**

**Chapter 5**

# **World Copper Resources**

# CONTENTS

	<i>Page</i>
<b>The Geology of Copper</b> .....	<b>91</b>
<b>Classes of Copper Deposits</b> .....	<b>91</b>
<b>Other Metals Occurring With Copper</b> .....	<b>92</b>
<b>Copper Resources and Reserves</b> .....	<b>94</b>
<b>Ore Grades</b> .....	<b>98</b>

## Box

<i>Box</i>	<i>Page</i>
<b>5-A. illustration of Expanding Reserves</b> .....	<b>98</b>

## Figures

<i>Figure</i>	<i>Page</i>
<b>s-1. Important Copper-Producing Areas in the Market Economy Countries</b> . . . .	<b>93</b>
5-2. McKelvey Box .....	95
5-3. Market Economy Country Copper Resources, 1985 .....	97
5-4. Average Ore Yields From U.S. Mines .....	100

## Tables

<i>Table</i>	<i>Page</i>
<b>5-1. Most Commonly Occurring Copper Mineral s.....</b> .....	<b>91</b>
<b>5-2. Summary of Demonstrated Market Economy Country Copper Resources in 1985</b> .....	<b>96</b>
<b>5-3. Overall Effect of Varying Cut-off Grade</b> .....	<b>99</b>



# World Copper Resources

A copper ore deposit is a localized zone in the earth's crust that contains copper-bearing minerals in unusually large quantities. On average, the continental crust contains about 0.0058 percent copper, or 58 parts per million. A deposit of copper-bearing minerals is classed as an ore reserve if there are sufficient quantities and concentrations of minerals to be extracted at a profit. Commercial copper ore deposits today contain from 0.5 to 6 percent copper, or between 100 and 1000 times the crustal average. In contrast, iron and aluminum constitute around 5.8 percent and 8 percent of the earth's crust, respectively, and their commercial deposits need to be only

3 to 10 times as concentrated as the crustal average. Thus, copper may be considered a relatively scarce element geochemically.<sup>1</sup>

This chapter begins with a description of the geology of copper—the kinds of copper minerals, how they formed, and where they are found. The chapter then discusses current world copper resources, and the copper content (or ore grade) of current mine production. The relations between ore grades, tonnages, and production costs are discussed in chapter 9.

<sup>1</sup>Brian J. Skinner, "A Second Iron Age Ahead?" *American Scientist*, vol. 65 (May/June 1976), pp. 258-269.

## THE GEOLOGY OF COPPER

Copper occurs in three different mineral groups (see table 5-1). In sulfide mineral deposits, the copper is linked with sulfur. In carbonate deposits, the copper occurs with carbon and oxygen. In silicate mineral deposits, the copper is linked with silicon and oxygen. The latter two groups are also termed oxide ores. Copper is more easily extracted from the sulfide and carbonate minerals.

### Classes of Copper Deposits

Copper deposits are classified by general geologic setting, including the type of rock in which the copper deposit formed. Rocks belong to three

main categories: igneous, sedimentary, and metamorphic. Each category is further subdivided on the basis of distinguishing characteristics such as mineralogical composition and texture. Igneous rocks generally form from a molten mass such as lava; sedimentary rocks form by the accumulation of material transported and deposited by water or wind, from chemical precipitation, or from the buildup of organic substances; and metamorphic rocks come from the effect of heat and pressure on other rocks.<sup>2</sup>

<sup>2</sup>Floyd F. Sabins, Jr., *Remote Sensing: Principles and Interpretation* (New York, NY: W.H. Freeman & Co., 1986).

Table 5-1.—Most Commonly Occurring Copper Minerals

Mineral	Elemental Components (weight percent)					
	Cu	Fe	S	CO <sub>2</sub>	SiO <sub>2</sub>	H <sub>2</sub> O
<b>Sulfides:</b>						
Chalcopyrite . . . . .	34.5	30.5	35.0	—	—	—
Bornite . . . . .	63.3	11.2	25.5	—	—	—
Chalcocite . . . . .	79.8	—	20.2	—	—	—
Covellite . . . . .	66.4	—	33.6	—	—	—
<b>Carbonates:</b>						
Azurite . . . . .	55.3	—	—	25.6	—	5.2
Malachite . . . . .	57.4	—	—	19.9	—	8.2
<b>Silicates:</b>						
Chrysocolla . . . . .	36.1	—	—	—	34.3	20.5

SOURCE: Cornelius S. Hurlbut (ed.), *Dana's Manual of Mineralogy* (New York, NY: Wiley, 17th ed., 1966)

The three main categories of copper deposits are porphyry type deposits, strata-bound deposits, and massive sulfide deposits. **Porphyry deposits are the most common. They account for about 45 percent of the world's total copper reserves, including the largest portion of the ore reserves in the western United States.** These deposits are associated with bodies of igneous intrusive rocks with copper sulfide minerals disseminated in them.

Porphyry deposits tend to occur in **discontinuous belts**. The best known is the belt that runs from Canada down through the southwestern United States, northern Mexico, Central America, and South America through Peru, Chile, and western Argentina. Another porphyry belt runs through Papua New Guinea, Indonesia, and the Philippines and on up into China and parts of Siberia; and a third through southeastern Europe, Iran, and Pakistan (see figure 5-1).

The grade and size of porphyry deposits varies. Typical deposits in Chile and Peru contain 1.0 to 2.0 percent copper and 500 million to 1 billion tonnes of ore, although the largest deposits may contain 4 to 5 billion tonnes. The deposits in the southwestern United States and northern Mexico contain 200 to 500 million tonnes of 0.4 to 0.8 percent copper ore. Those in the Philippines and Canada contain from 0.3 to 0.5 percent copper and from 50 to 200 million tonnes of ore.

**Strata-bound deposits**, the second most important in terms of metal reserves, are less common and smaller than porphyry deposits (1 million to 100 million tonnes of ore per deposit). Copper-bearing silicates, carbonates, and sulfides, occur in old marine sediments, such as shales and sandstones. Strata-bound copper reserves are found in Zambia and Zaire, as well as Europe and the north central United States (figure 5-1). **The Zambian deposits commonly contain 2.0 to 4.0 percent copper in sulfide minerals, and the Zairian deposits 4.0 to 6.0 percent copper in carbonate and silicate minerals.**

<sup>3</sup>United Nations Industrial Development Organization (UNIDO), *Technological Alternatives for Copper, Lead, Zinc and Tin in Developing Countries*, Report prepared for the First Consultation on the Non-ferrous Metals Industry, Budapest, Hungary, July 1987.

**Massive sulfide deposits** are large concentrations of mixed sulfide minerals (copper, nickel, lead, or zinc) occurring as veins and massive replacements in limestone, and as large bodies in volcanic rock sequences. Massive sulfide deposits are important in eastern Canada and the eastern United States, Australia, South Africa, the Philippines, and Cyprus. These deposits typically are small with well-defined boundaries and commonly have a copper content from 1.0 to 5.0 percent. Copper often is produced as a valuable byproduct of the other minerals in these deposits. The volume of ore reserves ranges from several hundred thousand to several million tonnes.

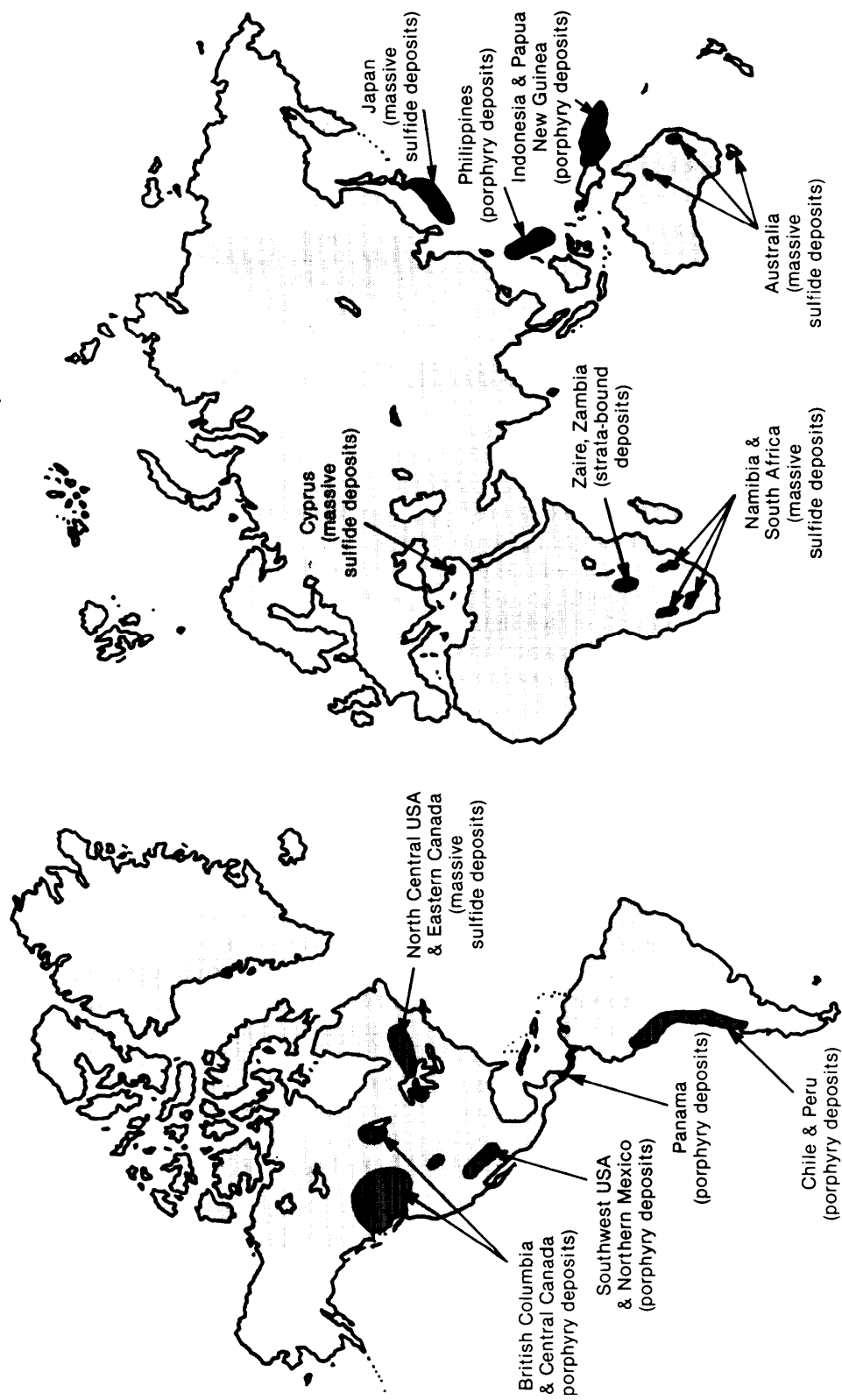
Most copper mineral deposits have definable boundaries; in some these are gradational and in others sharply defined (as in veins). Deposits with gradational boundaries, such as porphyry, often contain zones that are subeconomic in ore grade, which may become ore if either the price of copper increases or the cost of extracting the copper from the ore declines enough to make mining profitable. Thus, significant changes in perceived ore reserves may occur for such deposits as a result of cost or price changes.

### Other Metals Occurring With Copper

Many copper deposits contain more than one valuable metal. The other metals are classed as coproducts or byproducts, depending on their relative value. If the deposit is economically viable on the basis of copper production alone, then copper is the main product and any other metals are byproducts. If the economic viability of the deposit depends on the production of both copper and one or more additional metals, then copper and the other metal(s) are coproducts. Depending on current metal prices, the status of a metal occurring with copper can change from byproduct to coproduct and vice versa.

Each class of copper deposit is characterized by a different set of coproduct and byproduct metals. Important byproducts in porphyry deposits are molybdenum, silver, and gold. Molybdenum is a byproduct in some of the North and South American deposits, and is actually a coproduct for some of the Canadian deposits and U.S. deposits. Roughly 60 percent of world molybdenum

Figure 5-1.—Important Copper-Producing Areas in the Market Economy Countries



SOURCE: Raymond F. Mikesell, *The World Copper Industry* (Washington DC: Resources for the Future, 1979).

production is a result of copper mining.<sup>4</sup>The Bougainvillea and Ok Tedi deposits in Papua New Guinea, Ertsberg in Indonesia, and some Philippine deposits all have an unusually high gold content, but without any molybdenum.

The strata-bound deposits in Central Africa commonly have cobalt as a byproduct, with the Zairian deposits having a higher cobalt content.

<sup>4</sup>1 bid.

These deposits are the Western world's most important source of cobalt. s

The massive sulfide deposits contain significant amounts of nickel, or of lead and zinc. other metals of less importance in massive sulfide deposits are silver, gold, bismuth, cadmium, and cobalt.

<sup>5</sup>U.S. Congress, Office of Technology Assessment (OTA), *Strategic Materials: Technologies To Reduce U.S. Import Vulnerability*, OTA-ITE-249 (Washington, DC: U.S. Government Printing Office, January 1985)

## COPPER RESOURCES AND RESERVES

A general classification for describing the status of mineral occurrences was developed by the U.S. Geological Survey and the U.S. Bureau of Mines in 1976.<sup>6</sup>The so-called "McKelvey Box" (named after the then director of the U.S. Bureau of Mines, Vincent McKelvey) simplified the understanding of the economic relationships of the mineral resource classification system (see figure 5-2). **This system is based on a judgmental determination of present or anticipated future value of the minerals. The economic definitions on which the resource classification system is based are:**

- **Resource:** A concentration of a naturally-occurring mineral in a form and amount such that economic extraction of a commodity is currently or potentially feasible.
- **Identified Resource:** Resources whose location, grade, quality, and quantity are known or reliably estimated.
- **Demonstrated Resource:** Resources whose location and characteristics have been measured directly with some certainty (*measured*) or estimated with less certainty (indicated).
- **Inferred Resource:** Resources estimated from assumptions and evidence that minerals occur beyond where measured or indicated resources have been located.
- **Reserve Base:** That part of an *identified resource* that meets the economic, chemical, and physical criteria for current mining and

<sup>6</sup>U.S. Department of the Interior, Bureau of Mines and Geological Survey, *Principles of a Resource/Reserve Classification for Minerals* (Washington, DC: Geological Survey Circular 831, 1980).

production practices, including that which is estimated from geological knowledge (*inferred reserve base*).

- **Reserves:** That part of the *reserve base* that could be economically extracted at the time of determination.
- **Marginal Reserves:** That part of the *reserve base* that at the time of determination borders on being economically producible.
- **Undiscovered Resources:** Resources whose existence is only postulated.

These categories indicate different degrees of knowledge about the quantity of reserves in an ore body. For example, determination of measured reserves requires extensive drilling of the ore body (see ch. 6). However, only the existence of a minimum volume of ore must be proven in order to justify preparation of a feasibility study for a potential mine or mine expansion. Thus, indicated and inferred reserves may be a far larger figure because extensive drilling is costly and companies may not undertake drilling beyond what is required for the feasibility study. Nevertheless, many published figures on reserves use the broad sense of the term and include not only measured reserves, but also indicated and inferred reserves. z

The criteria for measuring reserves have not been standardized, so that totalling or comparing reserve estimates for different companies can be like adding or comparing apples and oranges.

<sup>7</sup>Raymond F. Mikesell, *The World Copper Industry: Structure and Economic Analysis* (Baltimore, MD: The Johns Hopkins Press, 1979).

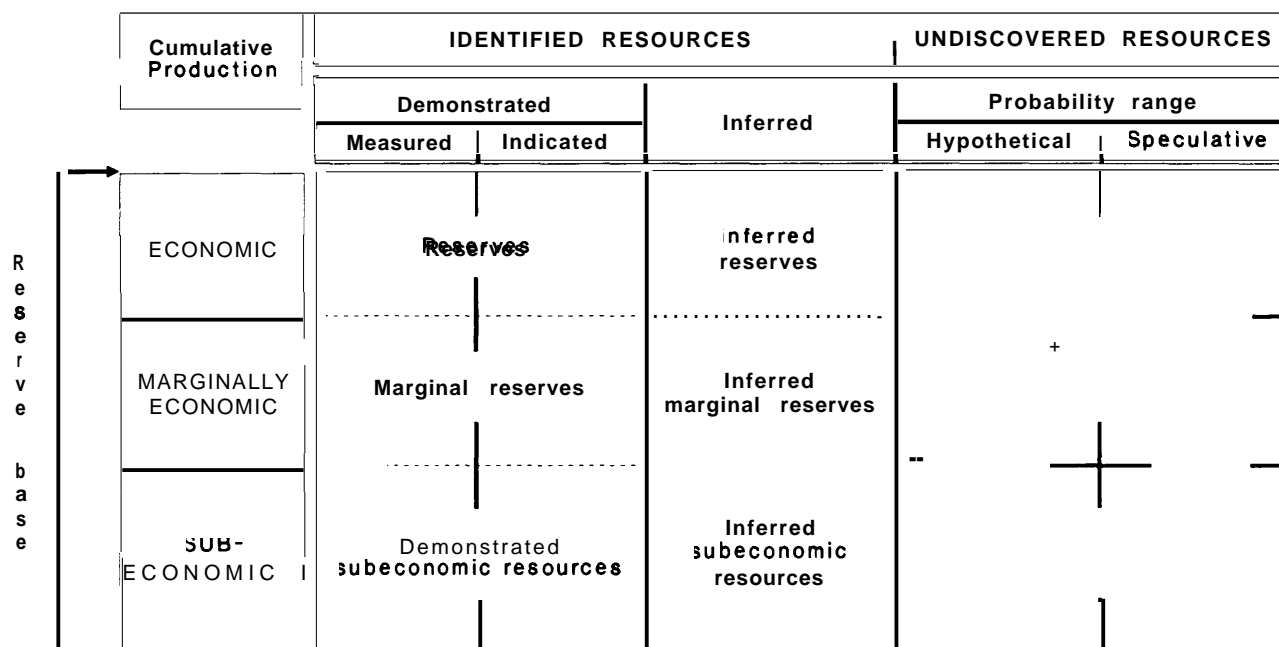
Figure 5-2.—McKelvey Box

## RESOURCES OF (commodity name)

(A part of reserves or any resource category may be restricted from extraction by laws or regulations)

AREA: (mine, district, field, State, etc.)

UNITS: (tons, barrels, ounces, etc.)



SOURCE U S Department of the Interior, Bureau of Mines and Geological Survey, "Principles of a Resource/Reserve Classification for Minerals," Geological Survey Circular 831, 1980.

The amount of perceived reserves in an ore body is a function of price and of extraction costs, and assumes that the net return on production will be sufficient to attract the required investment, including an allowance for risk. However, minimum acceptable rates of return or discounted cash flow rates will differ among companies, and between government enterprises and private companies. The potentially minable material in a deposit also varies with available technology and economic conditions. Resource estimates are revised periodically to account for changes in these factors.

Recognizing these uncertainties, the U.S. Bureau of Mines and the U.S. Geological Survey regularly develop estimates of world copper resources and reserves. Table 5-2 shows the Bureau of Mines 1985 copper resource and reserve estimates for 241 deposits in the market economy

countries. The U.S. Geological Survey estimates that total land-based copper resources (the reserve base plus a larger body of less well characterized resources) are around 1.6 billion tonnes, of which 35 percent are in the market economy countries.<sup>8</sup>

In 1985, demonstrated resources of recoverable copper<sup>9</sup> in the market economy countries were estimated at 333.4 million tonnes for 241 deposits. The Bureau of Mines estimates the total world reserve base at 566 million tonnes contained copper in ore.<sup>10</sup> Regionally, Latin America has the most abundant resources, with around

<sup>8</sup>Janice L.W. Jolly, "Copper," *Mineral Facts and Problems* (Washington, DC: U.S. Government Printing Office, 1985).

<sup>9</sup>Contained copper less mining and processing losses; includes oxide and leach material.

<sup>10</sup>Janice L.W. Jolly, "Copper," 1985 *Bureau of Mines Minerals Yearbook* (Washington, DC: U.S. Department of the Interior, Bureau of Mines, 1985).

**Table 5-2.—Summary of Demonstrated Market Economy Country Copper Resources in 1985<sup>a</sup>**  
(million metric tons unless otherwise specified)

	Number of deposits	In situ resource		Minimum resource		Recoverable resource
		Ore tonnage	In situ grade (% Cu)	Ore tonnage	Feed grade (% Cu)	
<b>North America<sup>a</sup></b>						
Canada	35	4,195	0.50	4,069	0.50	17.6
Mexico	6	4,468	0.68	29.1	0.65	20.5
United States <sup>b</sup>	62	16,204	0.53	85.7	0.51	57.4
Total or average <sup>c</sup>	103	24,867	0.55	35.7	0.53	95.5
<b>Central and South America</b>						
Chile	16	11,969	1.00	119.9	1.00	112.2
Peru	12	3,082	0.83	25.7	0.82	21.2
Other	8	3,098	0.66	20.6	0.66	17.3
Total or average <sup>c</sup>	36	18,149	0.92	166.2	0.91	150.7
<b>Europe</b>	12	929	0.84	7.8	0.79	5.5
<b>Middle East</b>	10	586	1.33	7.8	1.30	6.3
<b>Asia:</b>						
India	6	458	1.28	5.8	1.23	4.7
Philippines	22	3,211	0.47	5.0	0.47	10.4
Other	6	522	0.67	3.5	0.65	2.9
Total or average <sup>c</sup>	34	4,191	0.58	24.3	0.59	18.0
<b>Africa:</b>						
South Africa, Republic of	5	423	0.65	2.7	0.64	2.2
Zaire	8	677	4.04	27.3	4.09	20.7
Zambia <sup>d</sup>	9	621	2.58	16.0	1.97	10.2
Other	10	116	1.98	2.3	1.87	1.7
Total or average <sup>c</sup>	32	1,837	2.63	48.4	2.38	34.7
<b>Oceania:</b>						
Australia	9	2,261	1.69	38.3	2.00	26.0
Papua New Guinea <sup>e</sup>	5	3,639	0.47	17.2	NA	12.0
Grand total or average <sup>c</sup>	241	56,462	0.79	445.7	1.00	240.6

<sup>a</sup>Based on January 1985 resource estimates.

<sup>b</sup>Copper available from byproduct mines. Total world reserve base is estimated at 566 million tonnes contained copper in ore.

<sup>c</sup>Tonnage and grade figures include 4,969 million tonnes oxide and silicate material at 0.29 pct Cu. Sulfide resources and mill feed averaged 0.65 and 0.62 Cu, respectively.

<sup>d</sup>Data may not add to totals shown because of independent rounding.

<sup>e</sup>Tonnage and grade figures include 135 million tonnes oxide material at 0.70 pct Cu in Nchanga Stage III leach project. Primary resources and mill feed averaged 3.10 pct and 2.32 pct Cu respectively.

<sup>f</sup>Includes Namosi deposit in Fiji.

SOURCE: "Copper," *An Appraisal of Minerals Availability for 34 Commodities* (Washington, DC: U.S. Department of the Interior, Bureau of Mines, Bulletin 692, 1987).

43 percent of the western world's demonstrated resources of recoverable copper (see figure 5-3). North America ranks second with around 27 percent of the total. About 11 percent of demonstrated resources are located in Oceania and Australia, followed by Africa with around 10 percent, and Asia with 5 percent. The remaining 3 percent are located in Europe and the Middle East.

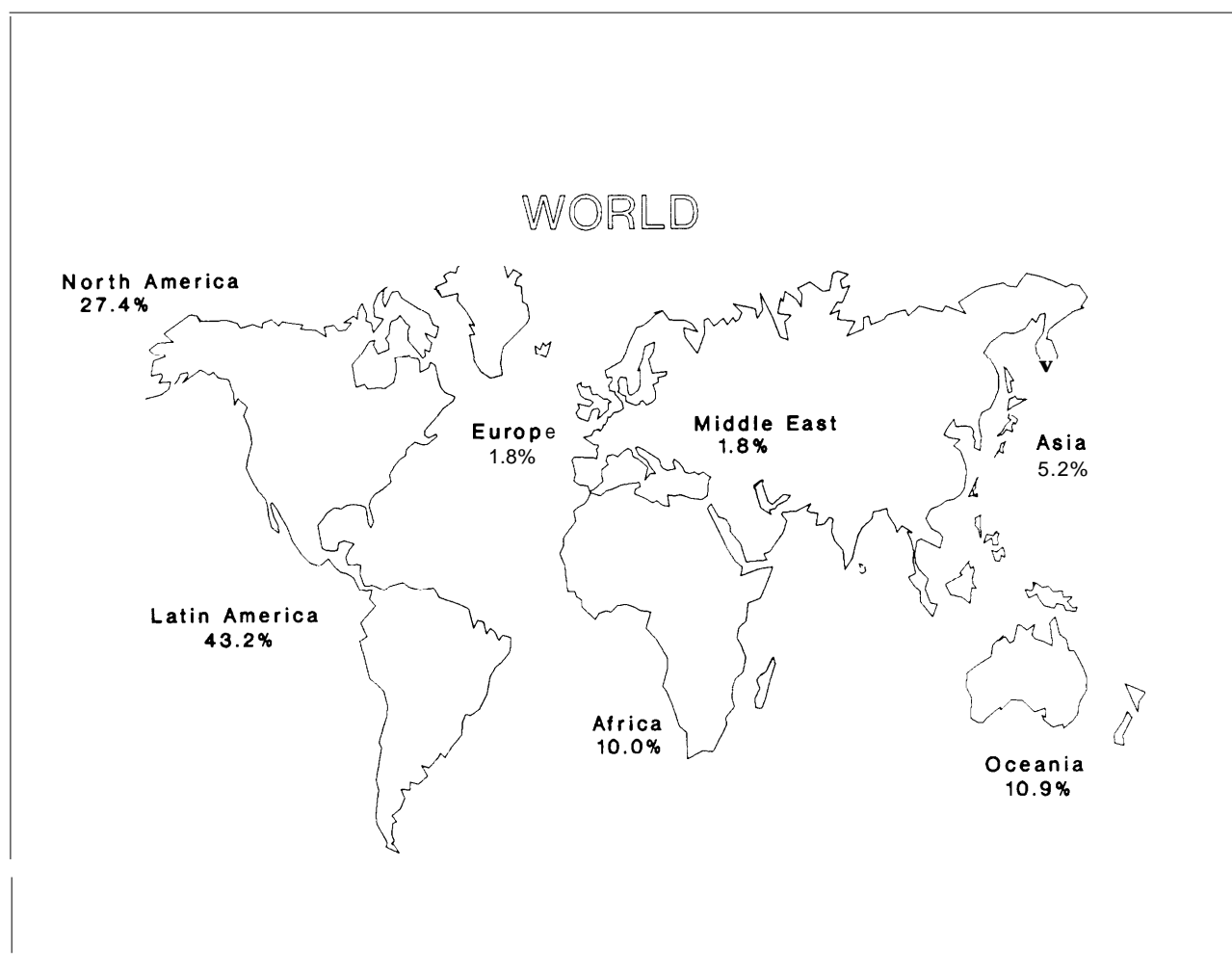
In terms of individual countries, nearly half of the market economy countries' copper resources are located in Chile and the United States, with approximately 32 and 17 percent of the total, re-

spectively. Australia ranks third in copper resources with 7 percent, and Peru, Mexico, and Zaire each have around 6 percent. The remaining 26 percent are located in approximately 33 other countries.<sup>11</sup>

More than 90 percent of U.S. copper reserves are located in five States: Arizona, Utah, New Mexico, Montana, and Michigan. Nearly all of the reserves are in mines for which copper is the

<sup>11</sup> "Copper," *An Appraisal of Minerals Availability for 34 Commodities* (Washington, DC: U.S. Department of the Interior, Bureau of Mines, Bulletin 692, 1987).

Figure 5-3.—Market Economy Country  
Copper Resources (1985)



SOURCE: U S Bureau of Mines data

principal product; small quantities are in base or precious metal mines where copper is a byproduct. Resources in Alaska and Minnesota also are

sizable, and may hold promise for future exploration.<sup>12</sup>

<sup>12</sup>Jolly, *Supra* note 8.

## ORE GRADES

Grade is the relative quantity or percentage of mineral content in an orebody. As discussed above, different types of copper deposits yield different amounts of ore, with strata-bound deposits generally having the highest grades, and porphyry the lowest. The ore grade determines how many tonnes of ore must be mined in order to produce a tonne of copper. For example, a mine with an ore grade of 0.5 percent must extract 200 tonnes of ore to produce 1 tonne of metal, but an ore running 2.0 percent copper only requires 50 tonnes to produce 1 tonne of metal. Similarly, to maintain copper production, the company mining 0.5 percent ore must discover 200 tonnes of new reserves for each tonne of metal produced.

The yield of copper ore from domestic and foreign mines has declined over time, both with the exhaustion of high-grade deposits and with technological changes that permitted profitable mining of lower ore grades.<sup>13</sup> For example, the initial discovery of copper in Butte, Montana was a 50-foot wide seam of rich "copper glance" (lustrous chalcocite) ore that ran 30 percent copper. As the copper glance was mined out and methods for processing lower grade ores were developed, mining at Butte moved into porphyry ores. Today, the average ore grade at Butte is closer to 0.5 percent copper. Box 5-A illustrates the relation between technological advances and resources, reserves, and ore grades using the Bingham Canyon, Utah mine as an example.

Currently, most of the world's copper production comes from ores with an average yield of around 0.79 percent copper. Individual countries' resources vary in average ore grade from a low of about 0.46 percent copper in Papua New Guinea and the Philippines to a high of around 4 percent copper in Zaire (see table 5-2). The United States has an average ore grade of 0.51

<sup>13</sup>The history of technological development and its relation to ore grade is discussed in ch. 6.

### Box 5-A.—Illustration of Expanding Reserves

The Bingham Pit is a classic example of how mineral reserves expand as mining and exploration proceed, and as technology and economics permit the mining of ever lower ore grades. The original prospectus for the Bingham Canyon Mine, issued in 1899, estimated that the deposit contained reserves of 12.4 million short tons of copper ore with an average grade of 2 percent. At that time, 2 percent was an extremely low-grade copper ore. In the early 1900s, financing for the mine was sought from the Guggenheim interests, who undertook an independent examination. That report, prepared around 1905, estimated the property to contain 40 million short tons of ore assaying 1.98 percent copper. In 1910, as development of the open pit proceeded, an adjacent property was merged with Bingham. By 1929, the reserve estimates had increased to 640 million tons of 1.07 percent ore, and by 1931 to 1 billion tons of 1.1 percent ore. The mine operated continuously until 1985, when it closed temporarily due to adverse conditions and for modernization. During the 80 years that the Bingham Pit has been in operation, it produced over 13 million tons of copper from 1.7 billion tons of ore. When it resumed operation after modernization, its production capacity was scheduled to be 185,000 tons of refined copper per year, or 110,000 tons of ore per day, with an average ore grade of 0.748 percent.<sup>1</sup>

<sup>1</sup>Adapted from A. B. Parsons, *The Porphyry Coppers* (New York, NY: The American Institute of Mining and Metallurgical Engineers, 1933), and Simon D. Strauss, *Trouble in the Third Kingdom* (London: Mining Journal Books Ltd., 1986).

percent copper for all types of copper minerals, including low-grade leachable deposits, and an average feed grade of 0.62 percent copper for sulfide resources.<sup>14</sup>

<sup>14</sup>U.S. Bureau of Mines, *supra* note 11.



The minimum grade that can be mined profitably from a deposit is termed the cut-off grade. The yield and tonnage of ore above the cut-off grade are critical both in estimating ore reserves and determining mine profitability. For example, although Africa is one of the least abundant regions of copper resources in terms of ore tonnage, it ranks third in recoverable copper as a result of its richer ore, which averages 2.38 percent copper. Central and South America, on the other hand, have only slightly better than average ore grades (0.91 percent), but rank first in recoverable copper due to the abundant tonnage. Similarly, North America has lower than average ore grades, but, because of the huge amount of ore, ranks second in recoverable copper.

Cut-off grade, in turn, is a function of the type of ore and mining operation. For example, a near-surface deposit may have a slightly lower cut-off grade than a deeper one, because the costs of removing the overlying waste rock and hauling the ore are lower. A mine with significant by-product or coproduct minerals (e.g., lots of gold) may have a lower cut-off grade than a mine where copper is the only mineral, because the ore's extra value "pays" for the more costly handling and processing.<sup>15</sup> Indeed, at mines where copper is a byproduct, the principal minerals may cover the full production cost and the copper represents profit.

In formulating a mine plan and determining the cut-off grade, there is a trade-off between deeper

<sup>15</sup>The role of byproduct credits and ore grades in production costs are discussed further in Ch. 9.

mines with higher grade ore, and wider mines that exploit the lower grades surrounding the main ore body. A copper producer must mine, crush/grind, and concentrate the total amount of ore. These processes consume large amounts of energy—both human and mechanical or electrical. Thus, the more material that has to be handled, the higher the cost tends to be. For example, with 1975 technology, producing cathode copper from 0.5 percent ore was estimated to require more than 3 times as much direct and indirect energy than producing lead from 4 percent ore.<sup>16</sup> Recovery rates<sup>17</sup> also tend to drop as the ore grade decreases (see table 5-3).

Ore grade and mineralization thus play a critical role in determining the competitiveness of a mining operation. The low grade of domestic copper resources often was cited as a critical factor in the poor competitive position of the U.S. industry during the early 1980s. Yet U.S. copper producers have actually increased ore yields in recent years (see figure 5-4). Improvements in metal recovery technology have meant less copper lost during processing. Mine plans have been adjusted to take advantage of lower-grade areas when prices are high, and higher grades when prices are low.<sup>18</sup> Also, because cut-off grades

<sup>16</sup>William C. Peters, *Exploration and Mining Geology* (New York, N.Y.: John Wiley & Sons, 1978).

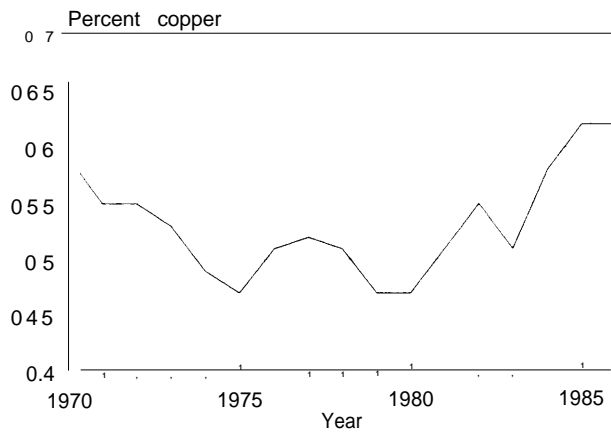
<sup>17</sup>The recovery rate is the amount of metal actually produced from the ore and not lost in tailings and other wastes, expressed as a percentage of the total available amount of ore.

<sup>18</sup>Note that this is not the same as high-grading, which is removing the higher grade ore from a deposit such as way as to preclude future mining of the lower grade material. (Over time, however, selective mining of the higher grade ores in a deposit will reduce the average grade of the remaining ore.)

Table 5.3.—Overall Effect of Varying Cut-off Grade

Cut-off grade (% Cu) . . . . .	0	.22	.29	.34	.40	.45
Tons milled (x 10 <sup>3</sup> ) . . . . .	26.60	23.52	21.07	19.09	17.44	16.06
Mill head grade (% Cu) . . . . .	0.45	0.50	0.55	0.60	0.65	0.70
Cu produced (tons) . . . . .	106.3	100,000	100,000	100,000	100,000	100,000
Btu/ton Cu (x 10 <sup>6</sup> ) . . . . .	0	101.0	97.9	95.9	95.1	95.7
Tons leached (x 10 <sup>3</sup> ) . . . . .	0	4.15	9.03	13.82	18.90	25.12
Dump grade (o/o Cu) . . . . .	0	0.17	0.22	0.24	0.27	0.29
Cu produced (tons) . . . . .	0	2,351	6,662	11,056	17,007	24,284
Btu/ton Cu (x 10 <sup>6</sup> ) . . . . .	0	93.7	93.7	93.7	93.7	93.7
Total tons treated (x 10 <sup>3</sup> ) . . . . .	26.60	27.67	30.10	32.91	36.34	41.18
Total Cu produced (tons) . . . . .	100,000	102,351	106,622	111,056	117,007	124,284
Average Btu/ton Cu (x 10 <sup>6</sup> ) . . . . .	106.3	100.8	97.6	95.7	94.9	95.3
Percent resource recovery . . . . .	0.835	0.822	0.787	0.750	0.751	0.671

SOURCE Charles H. Pitt and Milton E. Wadsworth, *An Assessment of Energy Requirements in Proven and New Copper Processes*, report prepared for the U.S. Department of Energy, contract No. EM-78-S-07-1 743, Dec 31 1980.

**Figure 5-4.—Average Ore Yields From U.S. Mines**

SOURCE: U.S. Bureau of Mines, Minerals Yearbook, various years

have declined so much in the last century, waste dumps contain significant copper resources; what was waste when the cut-off grade was 2 percent is now valuable ore. Waste-dump leaching (see ch. 6) exploits a tremendous in-place resource at a very low cost because the mining cost is already "off the books."<sup>19</sup>

<sup>19</sup> Jon K. Ahlness and Michael G. Pojar, *In Situ Copper Leaching in the United States: Case Histories of Operations* (Washington DC: U.S. Department of the Interior, Bureau of Mines, Circular No. 8961, 1983).

**Chapter 6**

# **Copper Production Technology**

# CONTENTS

	<i>Page</i>
<b>History</b> . . . . .	<b>103</b>
<b>Exploration</b> . . . . .	<b>113</b>
<b>Mining</b> . . . . .	<b>116</b>
Comminution and Separation . . . . .	127
Beneficiation. . . . .	130
Pyrometallurgy. . . . .	133
Hydrometallurgy . . . . .	140
Electrometallurgy. . . . .	142
Melting and Casting. . . . .	145

## Boxes

<i>Box</i>	<i>Page</i>
6-A. The Lakeshore Mine in Situ Project ..	126
6-B. Smelting Furnaces . . . . .	136

## Figures

<i>Figure</i>	<i>Page</i>
6-1. Flow Sheets for Copper Production . . . . .	104
6-2. Early Smelting Technology. . . . .	107
6-3. Early Copper-Producing Areas of Europe and the Middle East . . . . .	108
6-4. Copper Deposits of Northern Michigan . . . . .	109
6-5. Copper Production Areas of the Northern and Central Rocky Mountains . . . . .	112
6-6. Copper Production Areas of the Southwest . . . . .	112
6-7. Sample Geologic Map . . . . .	114
6-8. Model of Hydrothermal Alteration Zones Associated With Porphyry Copper Deposits . . . . .	115
6-9. Stages of Mineral Exploration ..	116
6-10. Underground Mining Terms . . . . .	119
6-11. Two Underground Mining Methods . . . . .	120
6-12. Open Pit Mining Terms . . . . .	121
6-13. Heap and Dump Leaching . . . . .	123

<i>Figure</i>	<i>Page</i>
6-14. Types of in Situ Leaching Systems ..	124
6-15. Jaw Crusher . . . . .	127
6-16. Hydrocyclone, . . . . .	129
6-17. Flotation Cells.. . . . .	130
6-18. Flowsheets for Copper Flotation ....	132
6-19. Column Cell . . . . .	133
6-20. Development of Smelting Technology Compared with World Copper Production . . . . .	135
6-21. Reverberatory Furnace . . . . .	136
6-22. Electric Furnace . . . . .	137
6-23. INCO Flash Furnace . . . . .	138
6-24. Outokumpu Flash Furnace . . . . .	138
6-25. Pierce-Smith Converter ... ..	139
6-26. Noranda Reactor . . . . .	139
6-27. Mitsubishi Continuous Smelting System . . . . .	140
6-28. Kennecott Cone Precipitator . . . . .	142
6-29. Flowsheet for Solvent Extraction ....	143
6-30. Continuous Casting Wheel . . . . .	146
6-31. Continuous Rod Rolling Mill ., . . . .	147

## Tables

<i>Table</i>	<i>Page</i>
6-1. Summary of Pyrometallurgical Processes . . . . .	105
6-2. Summary of Hydrometallurgical Processes . . . . .	106
6-3. Major U.S. Copper Mines . . . . .	110
6-4. Remote Sensing Systems and Image Types for Mineral Exploration . . . . .	117
6-5. Considerations in Choice of Mining Method . . . . .	118
6-6. Characteristics of Solution Mining Techniques . . . . .	122
6-7. Summary of in Situ Copper Mining Activities . . . . .	125
6-8. Smelter Technology in the United States . . . . .	138

# Copper Production Technology

The last boom in technological innovation for the copper industry occurred in the first two decades of this century, when open pit mining, flotation concentration, and the reverberatory smelter were adapted to porphyry copper ores. With the exception of leaching-solvent extraction-electrowinning, the basic methods of copper production have remained unchanged for 65 years. Moreover, six of the mines opened between 1900 and 1920 are still among the major copper producers in the United States today.

Instead of great leaps forward, technological innovation in the copper industry in the last 65 years has consisted largely of incremental changes that allowed companies to exploit lower grade ores and continually reduce the costs of production. Economies of scale have been realized in all phases of copper production. Both machine and human productivity have increased dramatically.

This chapter briefly describes the technology for producing copper, from exploration, through mining and milling, to smelting and refining or solvent extraction and electrowinning. The chapter begins with an overview of the history of copper technology development. Then, for each stage in copper production, it reviews the current state-of-the-art, identifies recent technological advances, reviews probable future advances and research and development needs, and discusses the importance of further advances to the competitiveness of the U.S. industry. Figure 6-1 shows flow-sheets for pyrometallurgical<sup>1</sup> and hydrometallurgical<sup>2</sup> copper production. Tables 6-1 and 6-2 provide capsule summaries of these processes.

<sup>1</sup>Pyrometallurgy is the extraction of metal from ores and concentrates using chemical reactions at high temperatures.

<sup>2</sup>Hydrometallurgy is the recovery of metals from ores using water-based solutions.

## HISTORY

As early as 6000 B. C., native copper—the pure metal—was found as reddish stones in the Mediterranean area and hammered into utensils, weapons, and tools. Around 5000 B. C., artisans discovered that heat made copper more malleable. Casting and smelting of copper began around 4000-3500 B.C. (see figure 6-2). About 2500 B. C., copper was combined with tin to make bronze—an alloy that allowed stronger weapons and tools. Brass, an alloy of copper and zinc, probably was not developed until 300 A.D.

Copper was first mined (as opposed to found on the ground) in the Timna Valley in Israel—a desolate area believed to be the site of King Solomon's Mines (see figure 6-3). The Phoenicians and Remans, who worked the great mines on Cyprus and in the Rio Tinto area of southern Spain, made the early advances in copper exploration and mining methods. For example, the Romans found nearly 100 lens-shaped ore bodies in the Rio Tinto copper district. Modern geologists

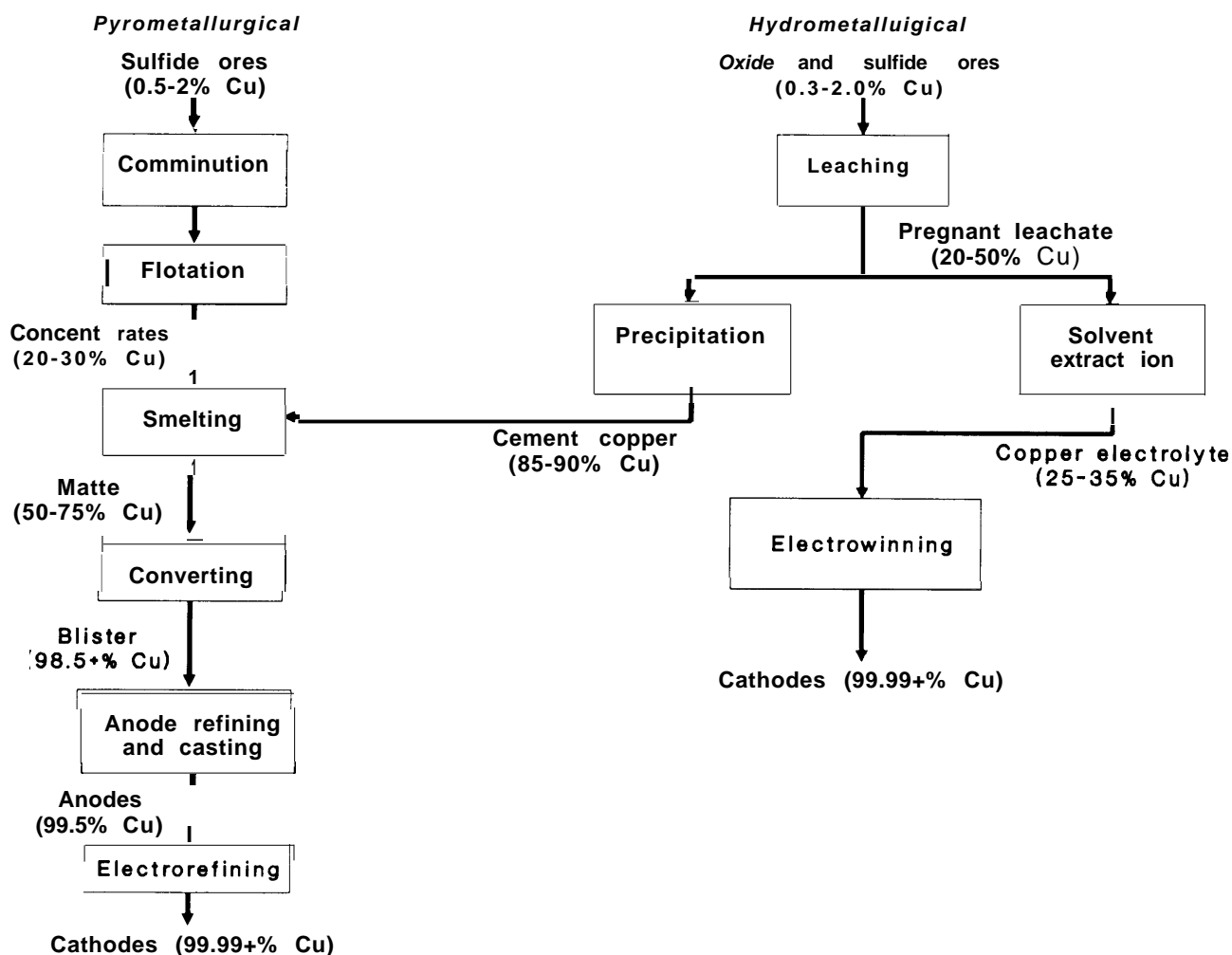
have found only a few additional deposits, and almost all of Rio Tinto's modern production has been from ore first discovered by the Remans.<sup>3</sup>

At Rio Tinto, the Remans mined the upper, oxidized, part of the ore and collected the copper-laden solutions produced by water slowly seeping down through the sulfide ore bodies. When the Moors conquered this part of Spain during the Middle Ages, the oxide ores had largely been exhausted. Learning from the Roman experience with seepage, the Moors developed open pit mining, heap leaching, and iron precipitation techniques that continued to be used at Rio Tinto into the 20th century.

In Britain, copper and tin were worked in Cornwall and traded with the Phoenicians as early as 1500 B.C. The Remans brought improved metallurgical techniques to Britain, and spurred devel-

<sup>3</sup>Ira B. Joralemon, *Copper: The Encompassing Story of Mankind's First Metal* (Berkeley, CA: Howell-North Books, 1973).

Figure 6-1.-Flow Sheets for Copper Production



SOURCE: Office of Technology Assessment.

opment of the mines of Cumberland and North Wales. When the Romans left Britain early in the 5th century, however, economic development stagnated and it was a thousand years or more before Britain's metal industry was reestablished.<sup>4</sup> In the interim, Germany became the center of the European copper industry, bringing a number of improvements in copper mining, metallurgy, and fabricating.<sup>5</sup>

<sup>4</sup>Sir Ronald L. Prain, *Copper: The Anatomy of an Industry* (London: Mining Journal Books Ltd., 1975).

<sup>5</sup>Raymond F. Mikesell, *The World Copper Industry: Structure and Economic Analysis* (Baltimore, MD: The Johns Hopkins Press, 1979).

King Henry VIII reopened the mines in Cumberland and elsewhere, and Britain became famed for bronze casting and the manufacture of armaments. By the end of the 16th century, Britain was producing 75 percent of the world's copper. British advances in metallurgy helped to establish a world monopoly in smelting that continued until around 1900, when foreign producers built large mills and smelters that took advantage of such British inventions as the reverberatory furnace and froth flotation. b Moreover, the miners

<sup>6</sup>Prain, supra note 4.

**Table 6-1.—Summary of Pyrometallurgical Processes**

Activity	Product	Constituents	Percent copper	Purpose or result
Big Bang . . . . .	Universe		0.0058	Formation of the earth
Hydrothermal alteration . . . . .	Porphyry rocks	Pyrite, chalcopyrite, etc.	0.2-6.0	Concentration of copper in earth's crust
Exploration and development . . . . .	Deposit	Copper ore, other minerals, waste rock (gangue)	0.2-6.0	Location of economic resource
Mining . . . . .	Ore	Copper minerals, iron and other metallic pyrites, byproducts, and gangue	0.5-6.0	Remove ore from ground and surrounding rock or overburden
Comminution. . . . .	Pulverized ore	Same as mining but in the form of fine particles	0.5-6.0	Creation of large surface area as preparation for flotation
Beneficiation (flotation) . . . . .	Concentrate	Copper minerals, iron pyrites, miscellaneous minerals (including valuable byproducts), and water (8-10%)	<b>20-300/o</b> dry	Removal of most gangue and collection of some byproduct minerals (e.g., Mo, Ni, Pb, Zn) to avoid further expense in materials handling, transportation, and smelting
Smelting. . . . .	Matte	Copper sulfide (Cu <sub>2</sub> S), iron sulfide (FeS), byproducts, tramp elements, and up to 3% dissolved oxygen	30-40% reverb, 50-75% flash	Heat-induced separation of complex sulfides into copper sulfides, iron sulfides, and sulfur; removal of sulfur as off gas (SO <sub>2</sub> ) and removal of gangue via slag; in oxygen-charged systems, partial (50-90%) oxidation of iron to produce iron oxide removed in the slag and to produce heat
Converting . . . . .	Blister	Copper with 0.5-2.0% dissolved oxygen and 0.05-0.2% sulfur, plus byproducts and some tramp elements	<b>98-99</b>	Oxidation and removal of most of the remaining iron and sulfur; oxidation of copper sulfide (Cu <sub>2</sub> S) to elemental copper and SO <sub>2</sub>
Fire refining. . . . .	Anode	Copper with 0.05-0.2% dissolved oxygen and 0.001-0.003% sulfur, plus byproducts and tramp elements	<b>98-99</b>	Further removal of oxygen via introduction of carbon or removal of sulfur via injected air to produce sheets strong enough and even enough for electrorefining (i.e., devoid of blisters)
Electrorefining . . . . .	Cathode	Copper with less than 0.004% metallic impurities. including sulfur	99.99	Collect byproducts (Ag, Au, PGMs) and remove tramp elements (Bi, As, Fe, Sn, Se, Te)

SOURCE: Office of Technology Assessment, 1988

Table 6-2.—Summary of Hydrometallurgical Processes

Activity	Product	Constituents	Percent copper	Purpose or result
<b>Big Bang</b> .....	<b>Universe</b>		0.0058	Formation of the earth
<b>Hydrothermal alteration and oxidation</b> .....	<b>Porphyry rocks</b>	Copper ores	0.2-6.0	Concentration of copper in earth's crust
<b>Exploration and development</b> .....	<b>Deposit</b>	Copper ore, other minerals, waste rock (gangue)	0.2-6.0	Location of economic resource
<b>Mining</b> <sup>a</sup> .....	<b>Ore</b>	Copper minerals, <sup>b</sup> iron and other metallic pyrites, byproducts, and gangue	0.5-6.0	Remove ore from ground and surrounding rock or overburden
<b>Leaching</b> .....	<b>Pregnant leachate</b>	Solution of copper and leaching agent (water or H <sub>2</sub> SO <sub>4</sub> )	20-50	Dissolution of copper from ore in sulfuric acid solvent, collection of solvent for cementation or solvent extraction
<b>Cementation (precipitation)</b> .....	<b>Cement copper</b> <sup>c</sup>	Copper, iron (0.2-2.00/0), trace amounts of silica and aluminum oxides, and oxygen	85-90	<b>Remove copper from pregnant leachate and remove some impurities</b>
<b>Solvent extraction</b> .....	<b>Copper electrolyte</b>	Organic solvent and pregnant leachate; then organic copper mixture plus H <sub>2</sub> SO <sub>4</sub>	25-35	Remove copper from pregnant leachate and produce an electrolyte with sufficient copper content for <b>electrowinning</b>
<b>Electrowinning</b> .....	<b>Electrowon cathodes</b>	Copper with less than <b>0.004%</b> metallic impurities	99.99	Recover copper from the loaded electrolyte solution, recover valuable byproduct metals (Au, Ag, <b>PGMs</b> ), eliminate tramp metals

<sup>a</sup>Mining is essentially a comminution process (see table 6-1); dump leaching uses materials that have already been mined and broken UP with explosives

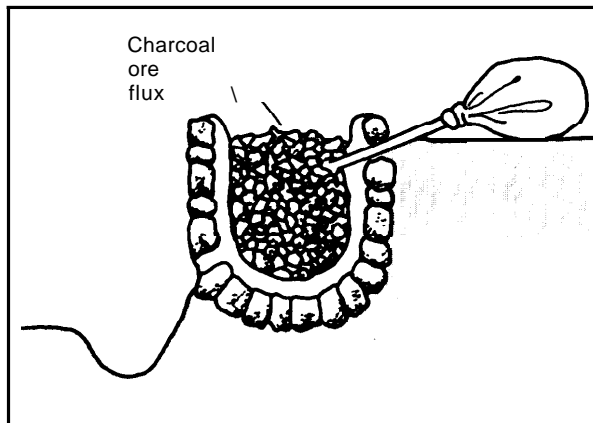
<sup>b</sup>Primarily low-grade oxidized minerals (e.g., malachite, azurite, chrysocolla, cuprite, tenorite) but also sulfide minerals in waste dumps.

<sup>c</sup>Cement copper usually is smelted, converted, and electrorefined (see table 6-1).

SOURCE: Office of Technology Assessment, 1966.

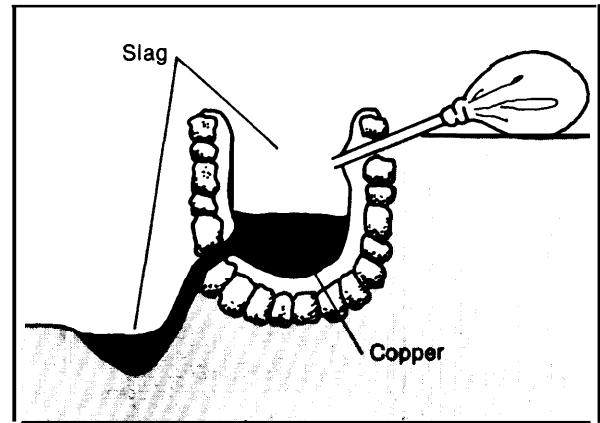


Figure 6-2.—Early Smelting Technology



The Egyptian copper smelting furnace was filled with a mixture of copper ore, charcoal and iron ore to act as a flux. It was blown for several hours by foot or hand bellows.

SOURCE Robert Raymond, *Out of the Fiery Furnace* (University Park, PA: The Pennsylvania State University Press, 1986)



By the end of the smelt the copper had separated from the slag, which was tapped off.

and metallurgists of Cornwall, Devon, and Wales provided much of the expertise for the early days of the American copper industry. '

Native Americans used native copper from the Keeweenaw Peninsula of Upper Michigan and from Isle Royale in Lake Superior as far back as 5000 B.C. (figure 6-4). The American colonies produced copper beginning in 1709 in Simsbury, Connecticut. By the 1830s, U.S. production in Connecticut, New Jersey, and other States was sufficient to supply the fabricators in Boston and New York, but the demand for finished copper and brass products was much greater than the Supply. o

Thus, the discovery of copper (and other mineral) deposits became an important part of westward expansion in North America. Each ore body is unique, however, and finding the ore often was easier than devising methods of economical copper production and transportation. Table 6-3 provides a chronology of the major copper mines in the United States, and the technological advances they contributed.

<sup>7</sup>Dona ld Chaput, *The Cliff: America's First Great Copper Mine* (Kalamazoo, MI: Sequoia Press, 1971).

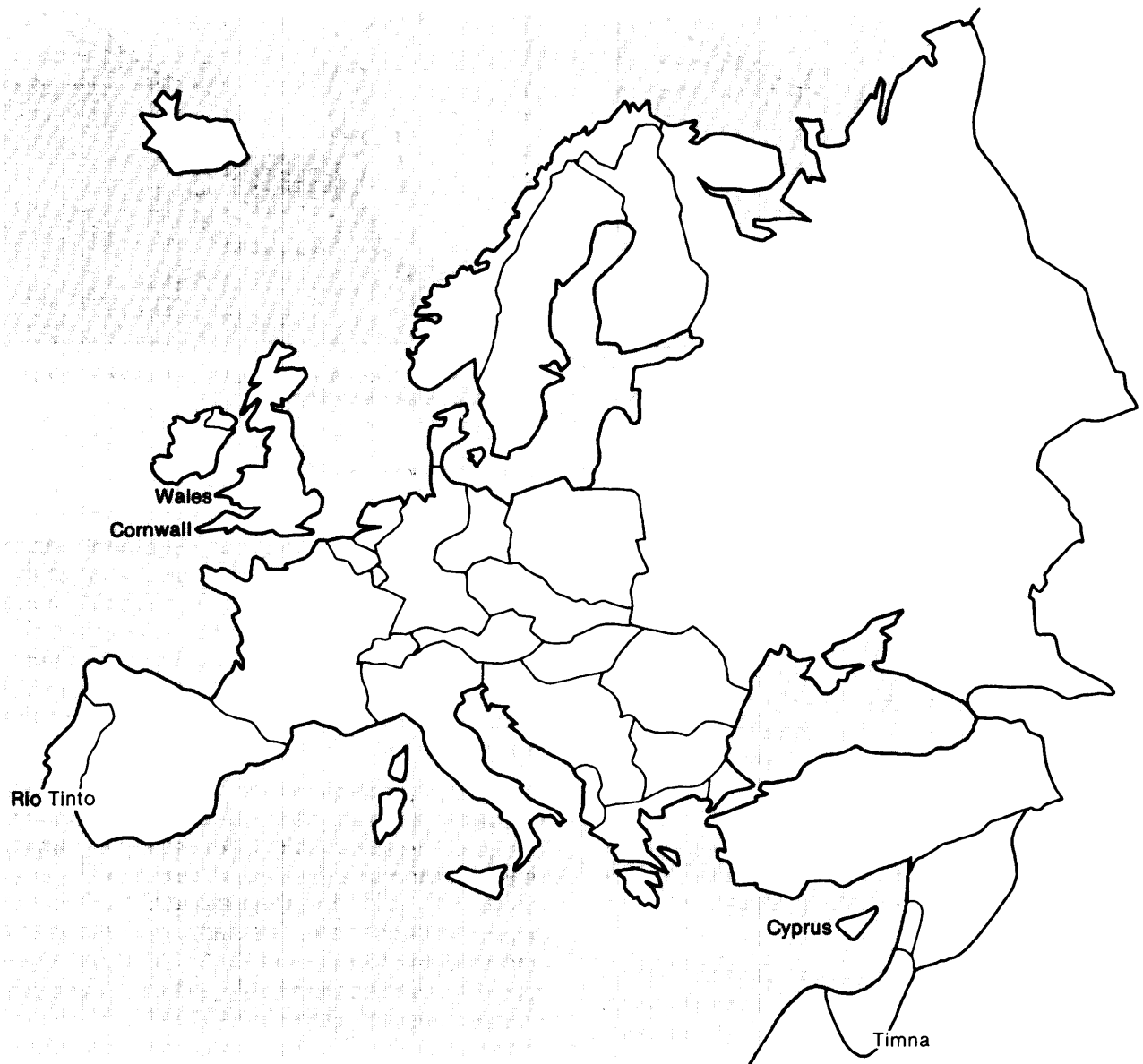
<sup>8</sup>Ibid.

Organized copper mine development began late in 1844 at Copper Harbor on the tip of the Keeweenaw Peninsula—the first regular mine shafts in the United States. The Cliff Mine, the first great copper mine in the Western Hemisphere, opened in 1845; it contributed advanced engines for hauling ore and miners out of the shafts, and for dewatering the mine. g

As the population moved West, the discovery of copper deposits often succeeded disappointing gold and silver claims. For example, mining in Butte, Montana (figure 6-5) began in the early 1860s with gold, and then moved to a body of silver and copper ore. The stamp mills (crushers) and smelting furnaces in Butte could not separate the silver economically, however, and the cost of transporting the ore 400 miles to the railroad was prohibitive. Butte was about to become another **Western** ghost town, when adaptation of smelting furnaces led to a silver boom. Then, in 1881, a huge seam of rich "copper glance" (chalcocite) that ran 30 percent copper turned Butte into "the richest hill on earth." Railroads were opened to Butte by the end of 1881, and it was soon a city of 40,000 with four copper

<sup>9</sup>Ibid.

Figure 6-3.— Early Copper-Producing Areas of Europe and the Middle East



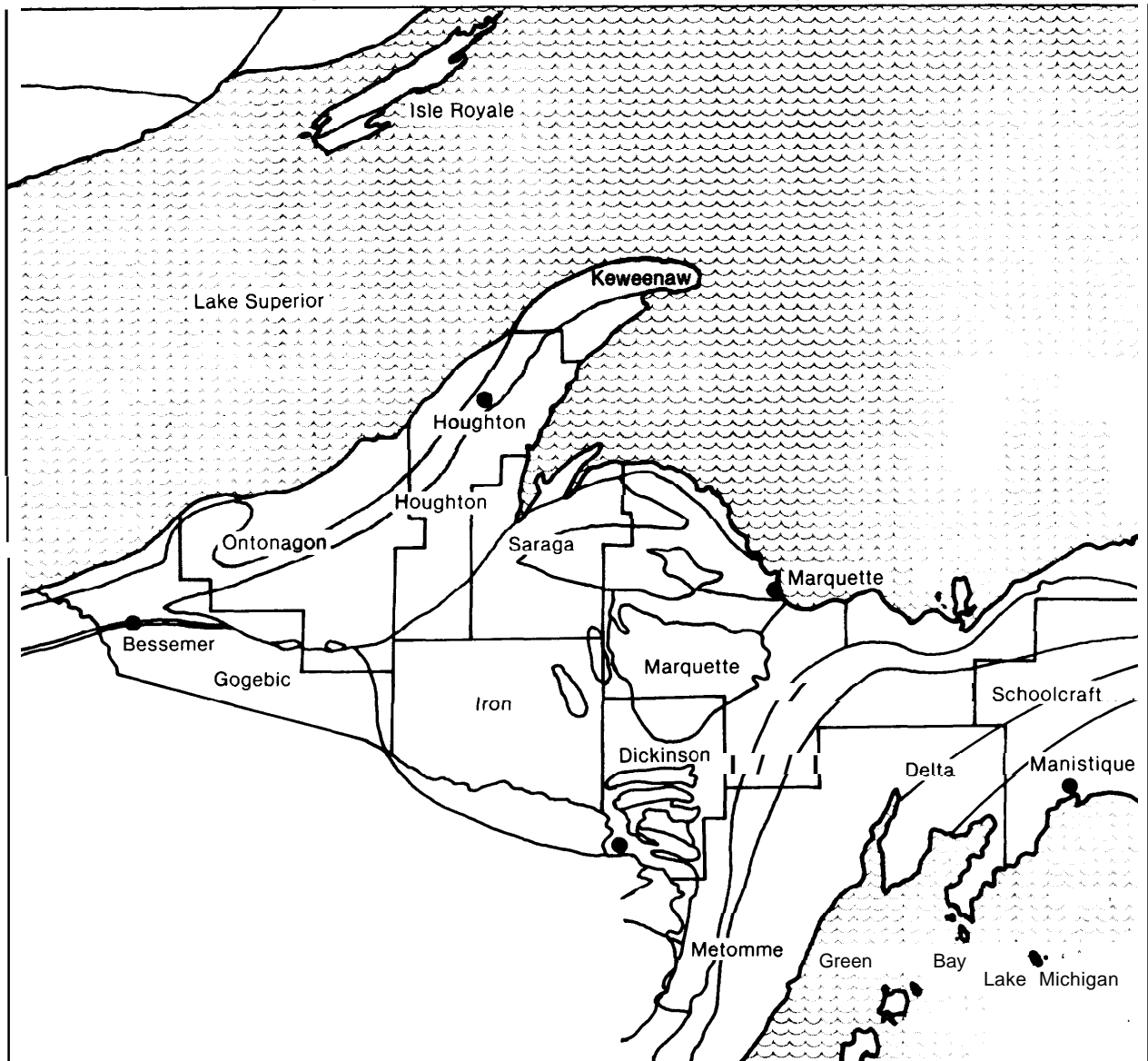
smelters. By 1887, Butte had passed the Lake Superior Copper Country in production.<sup>10</sup>

As in Montana, gold and silver mining in the Southwest paled into insignificance with the discovery and development of rich copper depos-

its. Also similar to Butte, profitable development of the southwestern deposits depended on construction of railways to transport the copper to fabricators, and on processing and smelting techniques that could economically handle the various grades and types of ore found, which included carbonates, oxides, sulfides, and silicates. A third factor was the amount of capital needed

<sup>10</sup>Joralemon, *supra* note 3.

Figure 6-4.—Copper Deposits of Northern Michigan



The thin band of the Keweenaw copper range shoots up through the peninsula, then goes beneath Lake Superior. Isle Royale is in the same geological formation.

SOURCE: Donald Chaput, *The Cliff: America's First Great Copper Mine* (Kalamazoo, MI: Sequoia Press, 1971).

to develop an ore body into a producing mine and provide the necessary infrastructure to exploit it.

The Southern Pacific Railroad was completed across Arizona in 1882, and lines eventually were extended to the various mining districts (see fig-

ure 6-6). Processing and smelting methods usually had to be tailored to each ore body or district. For example, in the early 1880s the mass-produced Rankin & Brayton water-jacket furnace revolutionized the smelting of oxide ores from the Bisbee district of Arizona. This furnace could be shipped as a complete unit, requiring

Table 6-3.—Major U.S. Copper Mines

Year opened	Year closed	Name	Location	Owner	Ore grade and type	Mine type	Technological advances <sup>a</sup>
1844	1845	Copper Harbor	Keeweenaw Peninsula, Michigan	Pittsburgh & Boston Mining Co.	silicate, black oxide of copper	UG	First regular mine shaft in U.S.
1845	1870 <sup>b</sup>	The Cliff	Keeweenaw Peninsula, Michigan	Pittsburgh & Boston Mining Co.	native copper	UG	First ore mass of native copper found in U.S.; development of mining and milling techniques used for at least two decades, including first Man Engine (hoist) in U.S.
1872	NA	Longfellow (and other shafts)	Clifton, Arizona	Arizona Copper Co.; then Phelps Dodge	20% then 4-5%	UG	First smelter in Arizona (1872); first railroad in Arizona; first concentrator (1886); first precipitation plant (1894); first successful mining of copper by block-caving (1910)
1875	NA	Morenci	Morenci, Arizona	Detroit Copper Co.; then Phelps Dodge	20%, then 4-5%	UG	Demonstration of large, mass-produced water-jacket furnace for smelting carbonate and oxide ores
1880	1975	Copper Queen <sup>c</sup>	Bisbee, Arizona	Copper Queen Mining Co., then Phelps Dodge	23%—malachite, azurite	UG	Furnace that would smelt copper and silver (1873); compressed air drills; first use of flotation (zinc—1912)
1881	1962	Anaconda (and many other shafts, later consolidated with Anaconda for open pit mining)	Butte, Montana	Anaconda Silver Mining Co. (later Amalgamated Copper), and Boston & Montana Co.; then Anaconda Minerals	30%—copper glance (chalcocite)	UG (open pit since early 1960s)	Economies of scale for milling (1907); first open-pit mining with steam shovels (1907); first porphyry mill (1904)
1881	NA	Old Dominion	Globe, Arizona	?, then Lewisohn Bros., then Phelps Dodge		UG	
1889	NA	United Verde	Jerome, Arizona	Senator Clark, then Phelps Dodge		UG	
1899	1917	Irish Mag	Bisbee, Arizona	Calumet & Arizona Mining Co.	30% oxides 15% sulfides	UG	
1907	active	Bingham	Bingham Canyon, Utah	Utah Copper Co., then Kennecott Copper Co., then BP Minerals America	2%—sulfides	OP	
1908	1978	Ely	Ely, Nevada	Nevada Consolidated Mining Co., then Utah Copper/Kennecott		OP & UG	
1910	1982	Superior	Superior, Arizona	Magma Copper Co.	4-6%—sulfides	UG	First pebble mill (1911)
1911	active	Miami	Miami, Arizona	Lewisohn Bros.	2.5%	UG	First large-scale caving mine; first organized chum drill
1911	active	Ray	Hayden, Arizona	Utah Copper/Kennecott, then Asarco		UG then OP	prospecting of copper (1908)
1911	active	Chino	Hurley, New Mexico	Utah Copper/Kennecott, then Phelps Dodge		OP <sup>a</sup>	
1915	active	Inspiration	Clayton, Arizona	Anaconda Minerals, then Inspiration Consolidated Copper Co., then Cyprus Mines	initially 2.5%, now 0.6% sulfides and oxides	UG then OP	First flotation plant for copper (1915); first electric rail haulage of copper underground (1926)
1916	NA	United Verde Extension	Jerome, Arizona				
1917	1984	New Cornelia	Ajo, Arizona	Calumet & Arizona Mining Co., then Phelps Dodge	0.6%—sulfides	OP	First sulfuric acid leaching (1917)
1921	1931	Sacramento Hill	Bisbee, Arizona	Phelps Dodge		OP	
1929	NA	Campbell	Bisbee, Arizona	Calumet & Arizona Mining Co., then Phelps Dodge	40% copper glance	UG	

**Table 6-3.—Major U.S. Copper Mines—Continued**

Year opened	Year closed	Name	Location	Owner	Ore grade and type	Mine type	Technological advances <sup>a</sup>
1940 . . .	active	<b>Bagdad</b>	<b>Bagdad</b> , Arizona	Cyprus Mines	0.5% —sulfides	OP	
1942 . . .	active	<b>Clay/Morenci</b>	<b>Morenci</b> , Arizona	Phelps Dodge	0.70/0—sulfides	OP	
1950 . . . . .	active	<b>San Manuel</b>	San Manuel, Arizona	Magma Copper Co.	0.6-0.70/. —sulfides	UG	
1954 . . . . .	7984	Silver Bell	Silver Bell, Arizona	<b>Asarco</b>	<b>4-6%</b> —sulfides	OP	
1955 . . . . .	1974	Lavender Pit	<b>Bisbee</b> , Arizona	Phelps Dodge		OP	
955 . . . . .	active	White Pine	White Pine, Michigan	Copper Range Co.	1 % —sulfides	UG	
957 . . . . .	active	Pima	<b>Sahuarita</b> , Arizona	Cyprus Mines	0.50/0—sulfides	OP	
959 . . . . .	1985	Twin Buttes	<b>Sahuarita</b> , Arizona	Anaconda, then <b>Anamax</b> , then Cyprus	0.920/0—sulfides	OP	First solvent extraction
988 . . . . .	active				0.730/0—oxides		<b>electrowinning plant (1976)</b>
962 . . . . .	active	Mission Butte	<b>Sahuarita</b> , Arizona	<b>Asarco</b>	sulfides	OP	
963 . . . . .	1983		Butte, Montana	Anaconda Minerals, then Montana Resources		OP	
986 . . . . .	active						
964 . . . . .	NA	Ithaca Peak	Mineral Park, Arizona	Duval		OP	
1969 . . . . .	active	Tyrone	Tyrone, New Mexico	Phelps Dodge	0.70/o—sulfides	OP	
1970 . . . . .	active	<b>Sierrita</b>	<b>Sahuarita</b> , Arizona	<b>Duval</b> , then Cyprus	0.3%-sulfides	OP	First in-pit crushing and conveying system
1972 . . . . .	1984	<b>Sacaton</b>	<b>Casa Grande</b> , Arizona	<b>Asarco</b>	sulfides	OP & UG	
1973 . . . . .	active	San Xavier	<b>Sahuarita</b> , Arizona	<b>Asarco</b>	sulfides	OP	
1974 . . . . .	active	Metcalf	<b>Morenci</b> , Arizona	Phelps Dodge	0.80A—sulfides	OP	
1974 . . . . .	leaching	Lake Shore	<b>Casa Grande</b> , Arizona	<b>Hecla</b> , then Noranda, then Cyprus	10/0 —oxides	UG	
1974 . . . . .	active	Pinto Valley	Miami, Arizona	Cities Service, then Magma	0.460/0—sulfides	OP	
1975 . . . . .	1986	Johnson	Benson, Arizona	Cyprus	0.40/0	OP	
1978 . . . . .	active	Eisenhower	<b>Sahuarita</b> , Arizona	<b>Anamax</b> , then <b>Asarco</b>	sulfides	OP	
1986 . . . . .	active	San Manuel	San Manuel, Arizona	Magma	oxides	OP	

NA indicates the actual date of closing or incorporation into open pit mining is unknown.

<sup>a</sup>Dates indicate first use in the U.S. unless otherwise indicated.

<sup>b</sup>Minor amounts of production continued under various owners until around 1903.

<sup>c</sup>Numerous other shafts were opened in Bisbee between 1877 and 1900, most of which were subsequently purchased by Phelps Dodge and managed jointly with the Copper Queen.

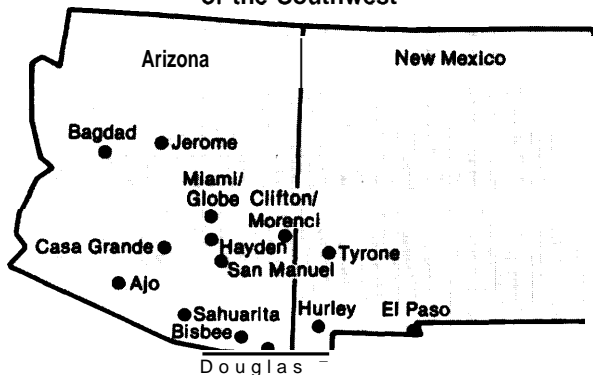
SOURCE: Office of Technology Assessment, 1988

Figure 6-5.—Copper Production Areas of the Northern and Central Rocky Mountains



SOURCE: Office of Technology Assessment, 1988.

Figure 6.6.—Copper Production Areas of the Southwest



SOURCE: Office of Technology Assessment, 1988.

few onsite engineering skills; it had improved fuel economy, important in the lightly forested mountains of southeastern Arizona; and it required no fire brick in its construction, which saved on shipping costs.<sup>11</sup>

Further developments in mining and processing technology followed the gradual decline in ore grades.<sup>12</sup> By the late 1800s, the **copper ore**

<sup>11</sup>Lynn R. Bailey, *Bisbee: Queen of the Copper Camps* (Tucson, AZ: Westernlore Press, 1983).

<sup>12</sup>The importance of ore grades for mine economics and competitiveness is discussed in ch.5.

grade in the Clifton-Morenci District of Arizona had declined to only 4 to 5 percent copper—too lean to be smelted directly at a profit. James Colquhoun devised a means of concentrating the ore based on techniques used to process Colorado gold ores. For some leaner oxide ores that could not be processed this way, Colquhoun worked out a process for dissolving the copper in sulfuric acid and precipitating it on iron. This first U.S. leaching plant was built in 1892.<sup>13</sup>

The adaptation of Colquhoun's techniques to deposits of low-grade porphyry ores was pioneered at Bingham Canyon in Utah, where gold and silver miners had found an unusually large mass of copper porphyry ore. But the ore grade, then estimated to average 2.22 percent copper, was too low to be exploited economically with traditional mining and smelting methods.<sup>14</sup> The Utah Copper Company's engineer, Daniel Jackling, determined that economies of scale were the key to making Colquhoun's concentration techniques economical with such low-grade ore. The Utah Copper Company's 5000-ton-per-day mill at Bingham Canyon began commercial production in 1907. Utah Copper made it even more profitable by introducing open-pit mining with steam shovels.<sup>15</sup>

Economies of scale in smelting also were realized in the early 1900s. Phelps Dodge had been having problems with the Copper Queen smelter in Bisbee as the mine went deeper and the copper carbonate and oxide graded into sulfide ore. An entirely new smelter was built 25 miles south of Bisbee, at a site named after James Douglas, head of Phelps Dodge's Bisbee operations. The most modern smelter of its time, it had five furnaces with a capacity of 5000 tons/day.<sup>16</sup> Phelps Dodge closed the Douglas smelter in 1987 because bringing it into compliance with air quality regulations would have been too costly.

As soon as Jackling showed that the low-grade porphyry could be mined profitably, they became the focus of exploration and development.

<sup>13</sup>Joralemon, supra note 3.

<sup>14</sup>The changes in ore grade over time, and their effects on the estimated resources in an ore body, are discussed in ch. 5, box 5-A.

<sup>15</sup>Joralemon, supra note 3.

<sup>16</sup>Bailey, supra note 11.

The Nevada Consolidated Company began production in Ely, Nevada in 1908. The Lewisohn Brothers partnership, which owned the Old Dominion Mine at Globe, Arizona, opened a porphyry mine at nearby Miami, Arizona in 1911. The Utah Copper Company opened Ray Mines in Arizona and Chino Mines in New Mexico in 1911. Phelps Dodge acquired claims and started development work at Tyrone, New Mexico, during the same period.<sup>17</sup> Most of these porphyry are still among the major producing ore bodies in the United States today.

Not all of the porphyry ores were amenable to Jackling's methods, however. For instance, available milling techniques could not recover enough of the 2.5 percent ore at the Inspiration Company's claims near Miami, Arizona. When Anaconda purchased these claims, their consulting engineer, L.D. Ricketts, expanded on Colquhoun's and Jackling's work plus developments in Britain, and built the first flotation plant for copper in the United States.<sup>18</sup> Similarly, profitable de-

velopment of the 30 million tons of 1.5 percent carbonate ore at Ajo, Arizona was questionable until Ricketts developed a process of leaching with sulfuric acid that would produce copper from Ajo ore for 8.5 cents/lb (the current selling price was 14 cents/lb).<sup>19</sup>

Phelps Dodge further refined these techniques during the 1930s. Under 1935 conditions, with the price of copper at 10 cents/lb, they proved that a profit could be made with ore that was only around 0.75 percent copper. However, demand was too low to open new low-grade mines until the wave of industrial development following World War II. **The accompanying technological advances that permitted economic exploitation of low-grade ore bodies included large-scale mining equipment that facilitated open-pit operations, and further improvements in crushing and flotation. More recent improvements, such as new smelting furnaces and hydrometallurgical processing methods, are described in the remainder of this chapter.**

<sup>17</sup>Prain, supra note 4.

<sup>18</sup>A zinc flotation plant had been built in Butte in 1912.

<sup>19</sup>Joralemon, supra note 3.

## EXPLORATION

Exploration includes all activities in the search for and discovery of new mineral deposits, plus the evaluations necessary to make a decision about the size, initial operating characteristics, and annual output of a potential mine. Exploration expenditures are highly sensitive to metal markets, as evidenced by the trends during the 1980s, when gold exploration has boomed while base metal exploration reached new lows. **U.S.** companies have drastically cut their base metal exploration staffs, land holdings, and most forms of prospecting.<sup>20</sup> Companies will continue exploration on a worldwide basis for a number of reasons, however. Their reserve base may be in mines at which production is not economic at current prices with existing technology, or they may have only a few years of production remaining at existing mines. Other countries may wish to increase mineral production to promote employ-

ment, enhance foreign exchange, and finance economic development. Even after discovery of a deposit and the start of mining, exploration continues in an effort to find additional ore that will keep the mine going for a longer time.

Modern exploration incorporates both direct and indirect techniques. Direct methods include geologic and photogeologic<sup>21</sup> mapping (figure 6-7); the study of rock types, geologic structures, and other indicators of an ore body (figure 6-8); and drilling and sampling. Indirect methods include geochemical<sup>22</sup> and geophysical<sup>23</sup> investi-

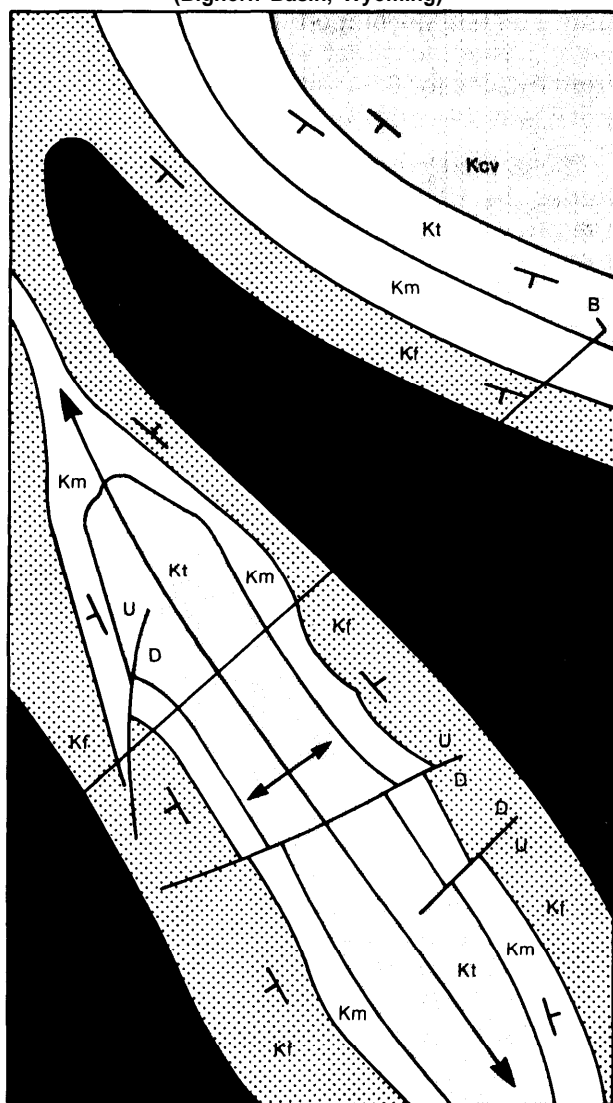
<sup>21</sup>Photogeology is the geologic interpretation of aerial photographs.

<sup>22</sup>Geochemistry is the study of the distribution and amounts of chemical elements in the Earth. Geochemical exploration uses the systematic measurement of one or more chemical properties of naturally occurring materials (e. g., rocks, glacial debris, soils, stream sediments, water, vegetation, and air) to identify chemical patterns that may be related to mineral deposits.

<sup>23</sup>Geophysics is the study of the earth by quantitative physical methods. Exploration geophysics applies the principles of physics

<sup>20</sup>"Mineral Exploration," *Engineering and Mining Journal*, July 1987.

Figure 6-7.—Sample Geologic Map (Bighorn Basin, Wyoming)



Structure symbols

- Fault
- Anticline
- Syncline
- Dip and Strike

0 1.0 km 1.0 mi

SOURCE: Floyd F. Sabins, *Remote Sensing: Principles and Interpretation* (New York, NY: W.H. Freeman & Co., 1987).

gations. Both direct and indirect methods are followed by Laboratory. analyses of ore samples, including ore treatment, concentration, and recovery tests; and evaluation of labor, transportation, water, energy, and environmental requirements. All of these studies must show favorable economic and technical results before a copper deposit can be considered a candidate for development. The cost of a total exploration program—from initial literature search through feasibility study—for a large porphyry copper deposit today ranges from 5 million to tens of millions of dollars.

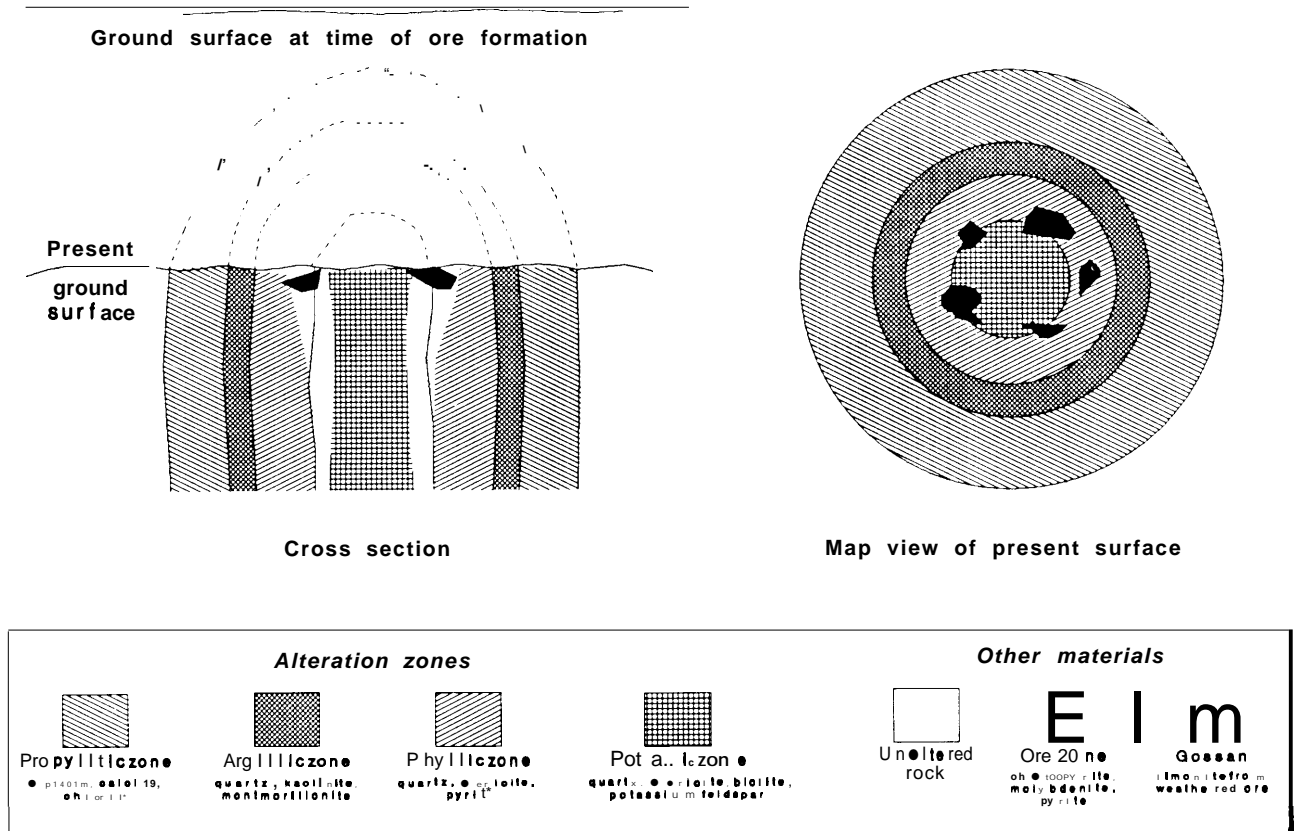
Exploration programs are divided into two main phases: reconnaissance and target investigation (see figure 6-9). Reconnaissance determines whether the probability of finding ore in an area is favorable enough to warrant more extensive—and more expensive—investigation. When a potentially favorable target area is found, the company must acquire the right to develop it. Land can be acquired by leasing or purchasing mineral rights owned by private parties, by staking claims on Federal lands, or by leasing Federal or State land. Some lands are unavailable for exploration and development due to withdrawal for other uses (e.g., wilderness, military reservations, water projects, or urban development).

Following acquisition, the exploration team investigates the target in detail, first on the surface, and then, if warranted, by drilling. The vertical samples of ore and surrounding material taken from drill holes are assayed to show the depth at which the ore or other rock was found, the type and thickness of the material, and other data. Then, metallurgical tests are run to determine amenability of the ore to flotation or other techniques for separating the minerals from the host rock.

to the search for mineral deposits. The geophysical properties and effects of subsurface rocks and minerals that can be measured at a distance with sophisticated electronic equipment include density, electrical conductivity, thermal conductivity, magnetism, radioactivity, elasticity, specific gravity, and seismic velocity. The techniques commonly used, either singly, or in combination in exploring for metallic minerals are magnetic, electrical, and electromagnetic, because these minerals usually have magnetic and electrical properties that contrast with those of the surrounding rocks.



Figure 6-8.-Model of Hydrothermal Alteration Zones Associated With Porphyry Copper Deposits



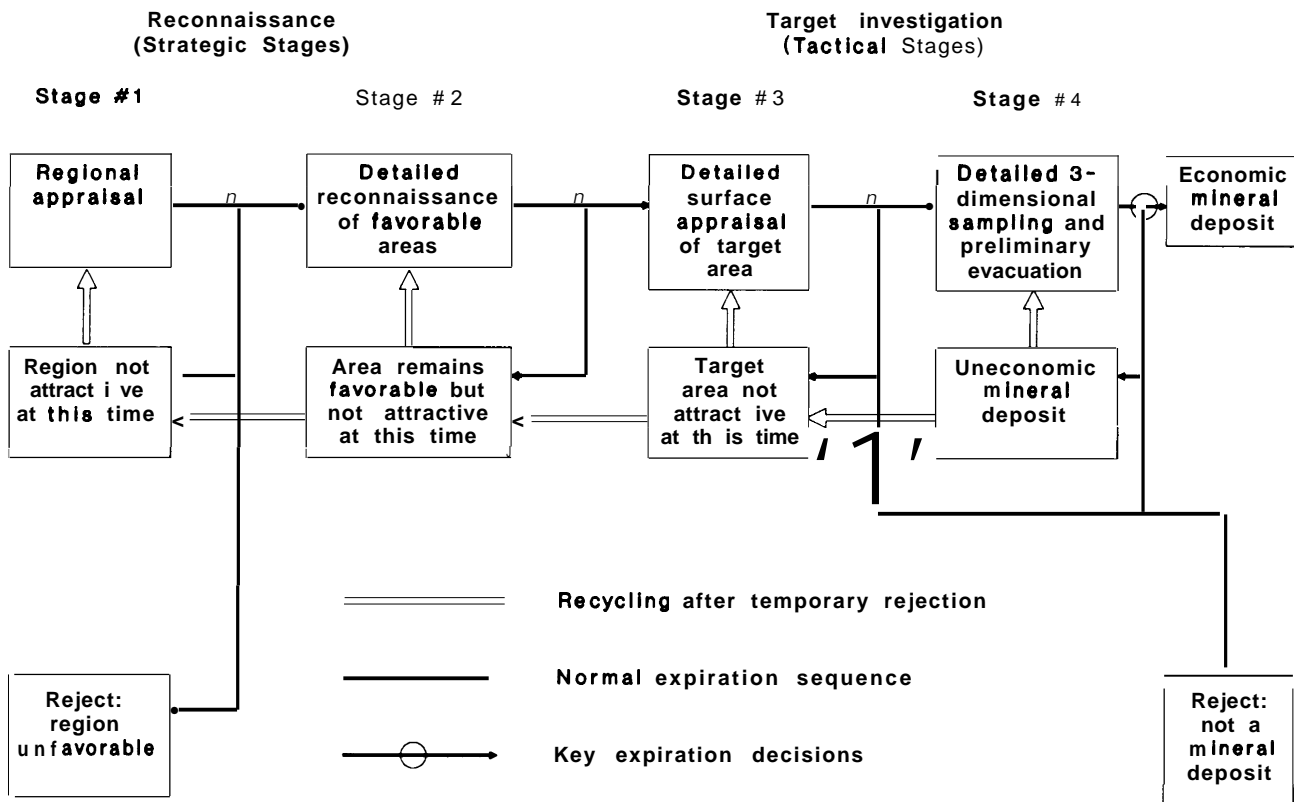
SOURCE Floyd F Sabins *Remote Sensing Principles and Interpretation* (New York, NY: W. H. Freeman and Co. 1987)

**Recent advances in exploration methods** include computer and statistical techniques for analyzing and integrating data, and remote sensing technologies (see table 6-4). In addition, the industry has benefited from refined geologic models of the formation of copper ore bodies, improved and cheaper drilling techniques, and deeper penetration of electrical geophysical methods.

In the near term, it is unlikely that exploration will reveal large new U.S. copper deposits that are

minable with available technology, although smaller high-grade deposits probably will be found (e.g., a 3 percent copper deposit reported in Montana in 1987). More likely are technological advances that would allow known lower-grade ores to be mined economically. Such advances would stimulate exploration for deposits to which the new technology would apply. Thus, the advent of solvent extraction and electrowinning methods for recovering copper stimulated exploration for oxide deposits.

Figure 6-9.-Stages of Mineral Exploration



SOURCE: Mineral Systems Inc., *Technological Innovation in the Copper Industry* (Washington, DC: U.S. Department of the Interior, Bureau of Mines, March 1983).

## MINING

Mining is the extraction of minerals from ore deposits. The term "mining" encompasses traditional methods such as underground, open pit, and placer mining, as well as more exotic techniques such as in situ solution mining.<sup>24</sup> Table 6-5 summarizes the considerations in choosing a mining method for a particular ore body. Conventional open pit mining currently accounts for around 75 percent of domestic copper production (86 percent if dump and heap leaching are included).

In general, solution mining has lower capital and operating costs than other methods, but

open pit mining offers the highest production rates and leaves the least ore behind. However, underground mining can reach greater depths. Open pit and solution mining have safety advantages over underground mining, but open pit methods have higher environmental costs than the other two. Theoretically, in situ solution mining may be more efficient than open pit mining, but its costs and production rates are unproven on a commercial scale.

**Mining (and milling) represent around three-quarters of the gross operating cost of producing a pound of copper.<sup>25</sup> U.S. operations are at**

<sup>24</sup>Solution mining is the leaching of ore with water-based chemical solutions. In situ solution mining treats the ore in place, i.e., without mining it first.

<sup>25</sup>This includes all aspects of mining and milling, from drilling and blasting of the overburden and ore, to transportation of concentrates to the smelter but excluding byproduct credits and working capital interest; see ch. 9.

**Table 6-4. — Remote Sensing Systems and Image Types for Mineral Exploration**

Image type	Wavelength region detected	Imaging system	Properties detected	Geology applications
Ultraviolet wavelength images	0.3-0.4 $\mu\text{m}$	Aerial cameras and scanners	Reflectance and fluorescence from solar radiation	Not useful
Visible and reflected IR wavelength photographs	0.4-0.9 $\mu\text{m}$	Aerial cameras, hand-held satellite cameras, Space Shuttle large-format camera	Spectral reflectance of solar energy in the visible and short wavelength IR regions; restricted to spectral sensitivity range of film	Identify visible topographic features, geologic structures (e.g. lineaments), and soil types for geologic mapping
Visible and multispectral reflected IR images	0.4-3.0 $\mu\text{m}$	Landsat Multispectral Scanner, Landsat Thematic Mapper, aerial scanners, Airborne Imaging Spectrometer, SPOT, Advanced Very High Resolution Radiometer	Spectral reflectance of solar energy in the visible and reflected IR regions	Geologic mapping, vegetative anomalies, rock types, hydrothermal alteration zones
Thermal IR images	3.0-14.0 $\mu\text{m}$	Aerial scanners, Heat Capacity Mapping Mission, Landsat Thematic Mapper band 6, and Thermal IR Multispectral Scanner	Radiant temperature, which is determined by kinetic temperature, emissivity, and thermal inertia	Rock types, surface moisture geologic structures
Radar	1.0-30 cm	Aerial systems, Seasat, Shuttle Imaging Radar	Surface roughness and dielectric properties	Enhancement of geologic features, especially through dense vegetation or cloud cover, imaging of buried bedrock surfaces

SOURCE: Floyd F. Sabins, *Remote Sensing: Principles and Interpretation* (New York, NY: W. H. Freeman & Co., 1987).

**Table 6.5.—Considerations in Choice of Mining Method**

<b>Physical:</b>	
Geometry . . . . .	Size, shape, continuity, and depth of the orebody or group of orebodies to be mined together Range and pattern of ore grade
Geology . . . . .	Physical characteristics of ore, rock, and soil Structural conditions Geothermal conditions Hydrologic conditions
Geography . . . . .	Topography Climate
<b>Technological:</b>	
Safety . . . . .	Identification of hazards
Human resources . . . . .	Availability of skilled labor
Flexibility . . . . .	Selectivity in product and tonnage
Experimental aspects . . . . .	Existing or new technology
Time aspects . . . . .	Requirements for keeping various workings open during mining
Energy . . . . .	Availability of power
Water requirements . . . . .	Amount and availability
Surface requirements . . . . .	Area needed
Environment . . . . .	Means of protecting the surface, water resources, and other mineral resources
<b>Economic:</b>	
Cost limits . . . . .	
Optimum life of mine . . . . .	
Length of tenure . . . . .	Prospects of long-term rights to mine

SOURCE William C. Peters, *Exploration and Mining Geology* (New York, NY: John Wiley & Sons, 1978)

a competitive disadvantage in mining because of relatively low average ore grades, only moderate byproduct credits, and high labor and environmental costs. Little can be done about the first two, and labor costs were lowered substantially in 1986. Therefore, further decreases in mining costs must come from improvements in mine technology and productivity. For instance, the Bureau of Mines estimates that in situ solution mining could make a domestic low-grade deposit competitive with foreign production from higher grade ores using conventional mining methods.<sup>26</sup> Conversely, any significant increase in mining cost could devastate the domestic industry.

<sup>26</sup>Mineral Systems Inc., *Technological Innovation in the Copper Industry* (Washington, DC: U.S. Department of the Interior, Bureau of Mines, March 1983).

**Underground mining methods usually** are used for deep ore bodies where an open pit would be impractical because of excessive waste removal. Figure 6-10 illustrates the basic terms applicable in underground mining; figure 6-11 shows two types of underground copper mines. Underground development and maintenance, including tunneling, rock support, ventilation, electrical systems, water control, and transportation of people and materials, add significantly to mining costs.

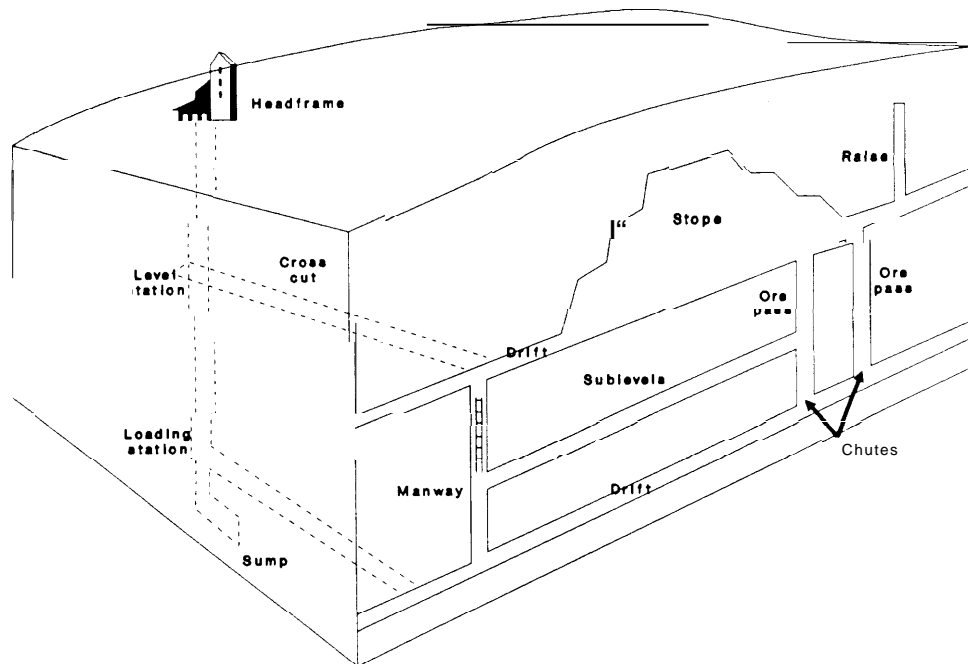
**Open pit mining is used to extract massive deposits** that are relatively near the surface. An open pit bench mine has the appearance of a bowl, with sides formed by a series of benches or terraces arranged in a spiral, or in levels with connecting ramps (figure 6-1 2). After removal of the overlying waste (overburden), the ore is blasted loose. Large electric or diesel shovels (or front-end loaders in smaller operations) load the ore onto trucks or conveyor belts for transport to the crusher. Open pit mining has lower development and maintenance costs than underground mining because it requires fewer specialized systems. However, the land disturbance is much greater and environmental costs can be high (see ch. 8).

In solution mining, or leaching, water or an aqueous chemical solution percolates through the ore and dissolves the minerals. The resulting mineral-laden solution, known as pregnant leachate, is collected and treated to recover the valuable minerals. Table 6-6 summarizes the four types of solution mining.

Vat, heap, and dump leaching are methods of hydrometallurgical processing of mined ore (see figure 6-13). Thus they are complements, not alternatives, to underground or open pit mining. In situ leaching is a stand-alone mining method (see figure 6-14). The leach solution percolates through the ore to be collected in wells or underground mine workings. Natural fractures or the effects of earlier mining can supply channels for the leach solution, or the ore can be blasted or fractured hydraulically.<sup>27</sup> U.S. companies have

<sup>27</sup>Jon K. Ahlness and Michael G. Pojar, *In Situ Copper Leaching in the United States: Case Histories of Operations* (Washington DC: U.S. Department of the Interior, Bureau of Mines, Circular No. 8961, 1983).

Figure 6-10.-Underground Mining Terms



SOURCE William C Peters, *Exploration and Mining Geology* (New York, NY: John Wiley & Sons, 1978)

mined copper in situ at 24 known sites (see table 6-7 and box 6-A).

Solution mining enjoys certain intrinsic advantages over conventional mining and milling, including lower combined capital and operating costs, faster start-up times, and fewer adverse environmental impacts. Furthermore, solution mining is an expedient method of extracting metals from small, shallow deposits and is particularly suited to low-grade resources. Leaching old mines (where the ore that can be mined economically has been removed) and leaching waste dumps both use an in-place resource for which the mining cost is already "off the books."<sup>28</sup> As a result of these advantages, solution mining has gradually taken over an increasing percentage of domestic mine production (see ch. 4).

**There have been no truly radical technological advances in mining technology for at least the last several decades.** Witness a 1983 U.S. Bureau of Mines report on *Technological Innovation in the Copper Industry* that had to stretch

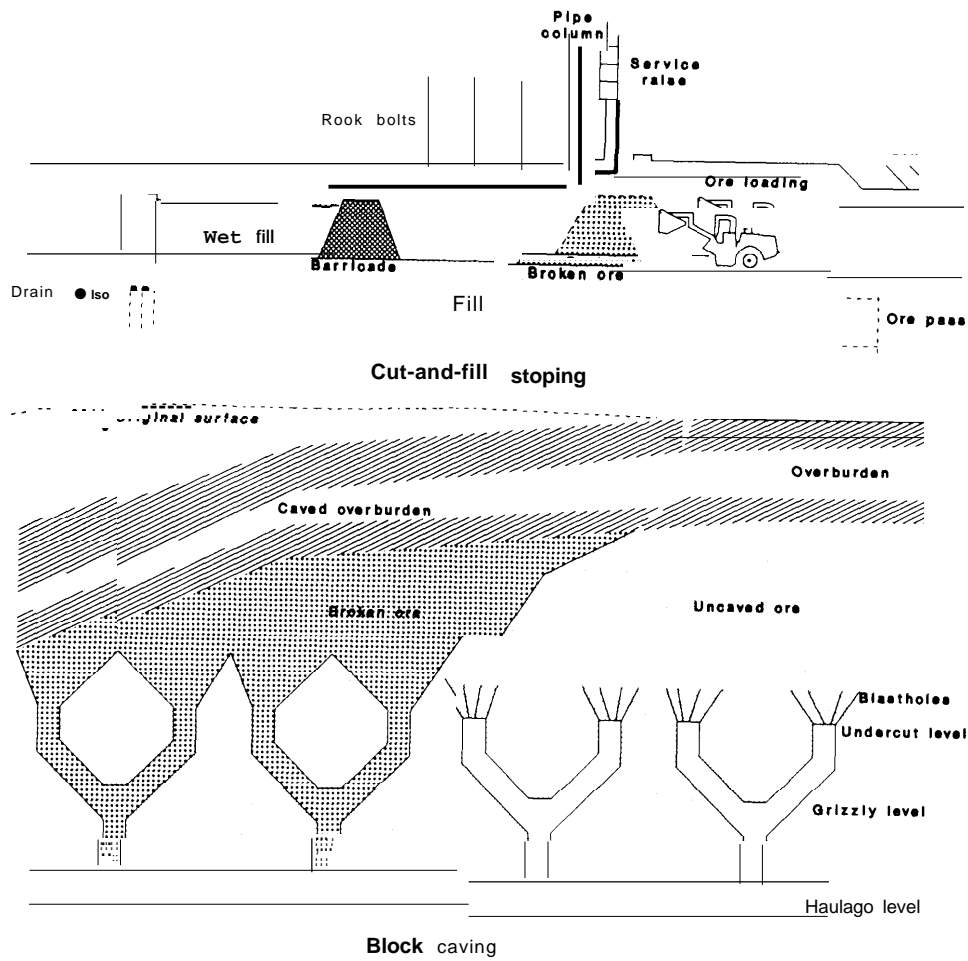
<sup>28</sup> | bid.

its time frame to the last 30 to 50 years to develop a list of innovations.<sup>29</sup> Instead, incremental improvements in existing methods, and adaptations of other types of technology to mining (e.g., computers, conveyor systems) have gradually reduced costs and increased productivity. These include improved drilling and blasting equipment and practices; larger and more efficient trucks and shovels; more efficient underground equipment such as hoists and ventilation fans; computerized truck dispatching for open pit mines; computerized and remote control systems for underground mine pumps and trains; in-pit ore crushing and conveying; and improved slope stability analyses that allow steeper pit walls.

Possible future technological advances that could provide important productivity gains in copper mining include further demonstration and development of in-pit crushing/conveying; an underground continuous mining machine adaptable to various ore and mine types; and in situ solution mining of virgin ore bodies.

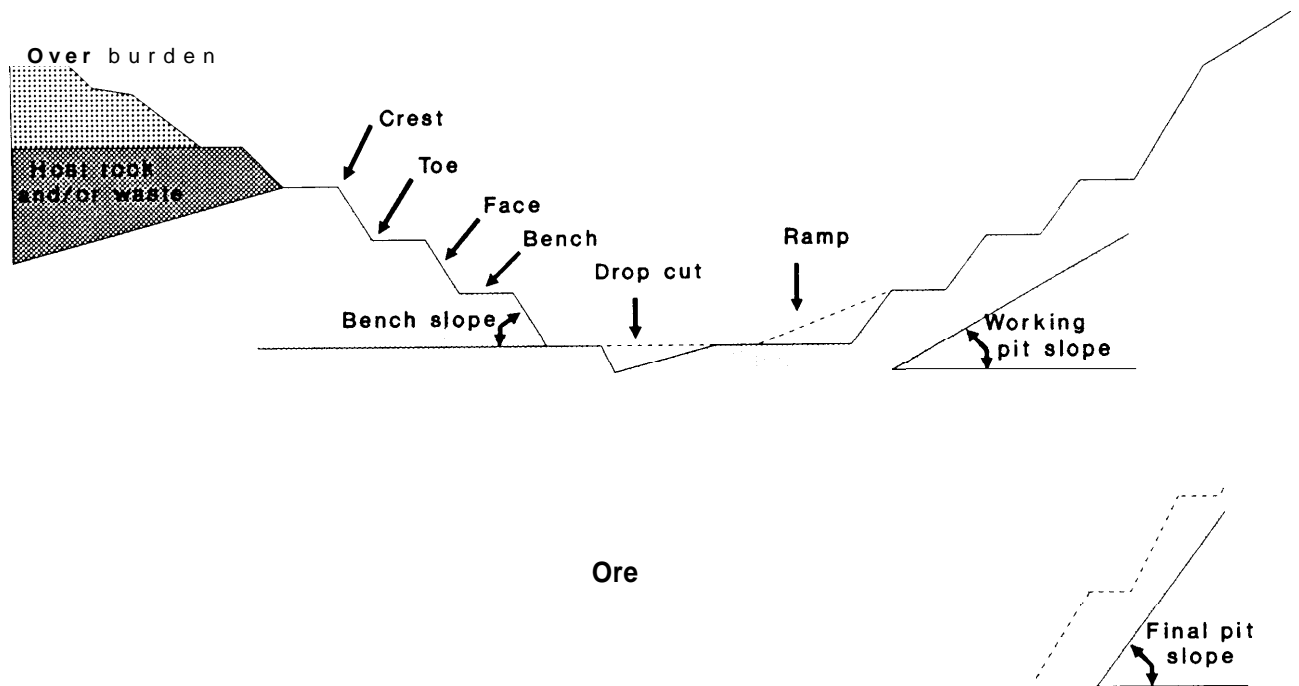
<sup>29</sup> Mineral Systems Inc., *supranote26*

Figure 6-11.-Two Underground Mining Methods



SOURCE: William C Peters, *Exploration and Mining Geology* (New York, NY John Wiley & Sons, 1978)

Figure 6-12.-Open Pit Mining Terms



SOURCE William C Peters. *Exploration and Mining Geology* (New York, NY: John Wiley & Sons, 1978)

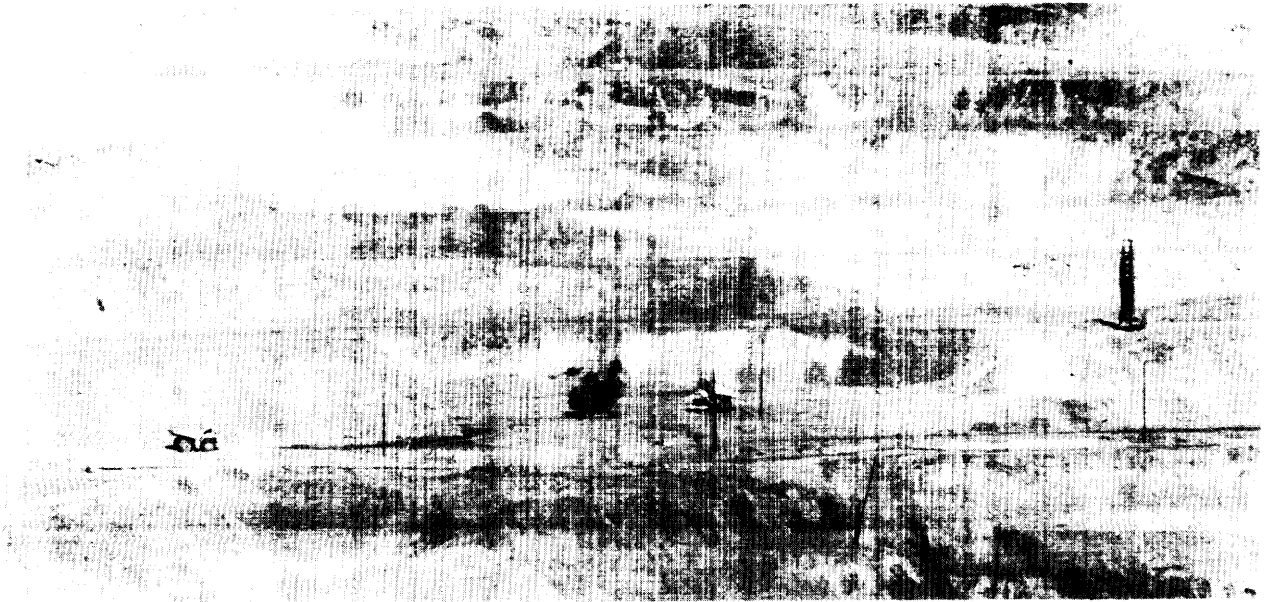


Photo credit: Jenifer Robison

Portion of an open-pit mine, showing benches. Holes for the explosives are drilled (right). After the ore is blasted loose, large shovels load the ore into trucks (center) for hauling to the primary crusher.

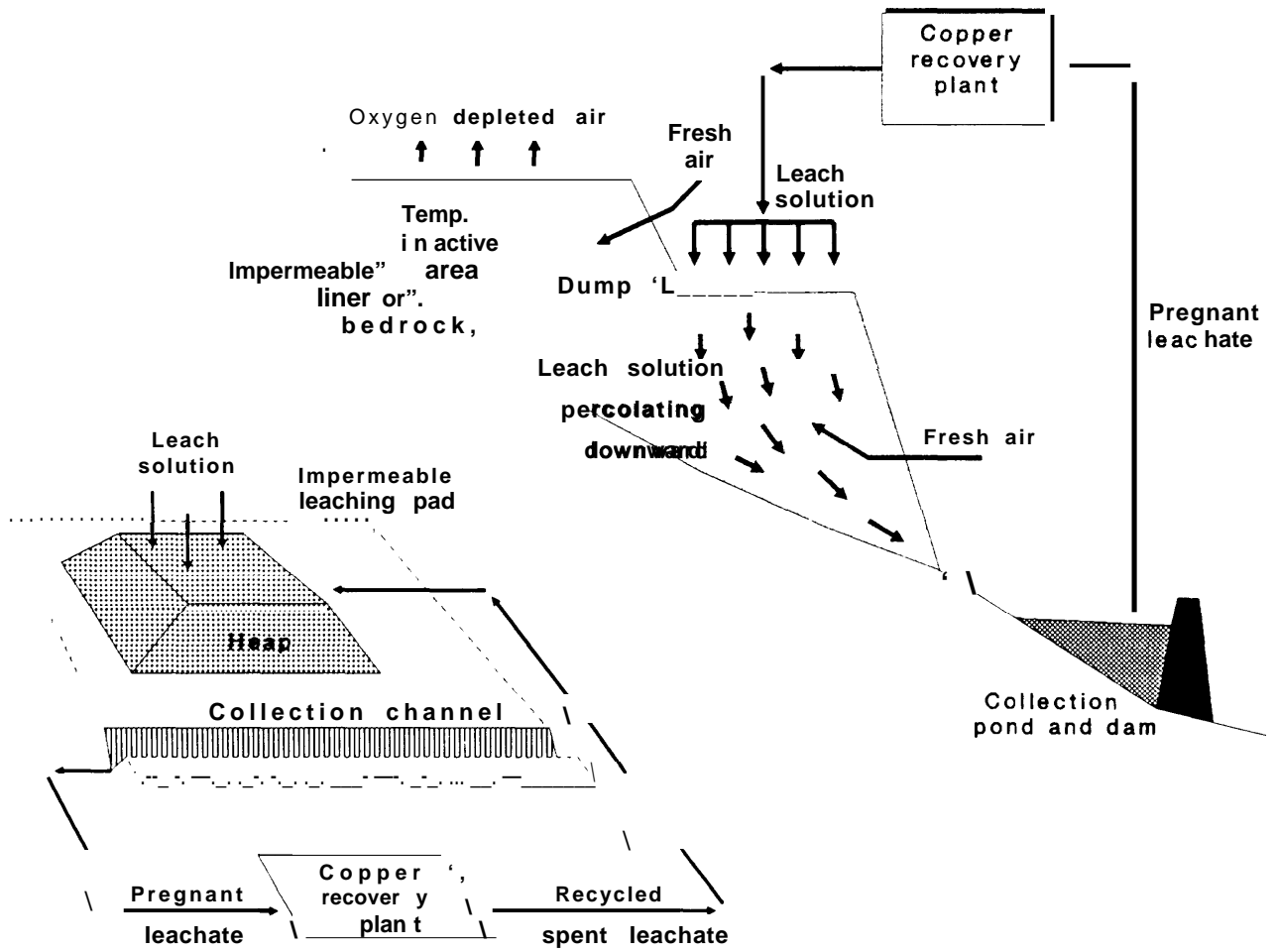
Table 6-6.—Characteristics of Solution Mining Techniques

	Vat leaching	Heap leaching	Dump leaching	In situ leaching
Ore grade. . . . .	Moderate to high	Moderate to high	Low	Low
Type of ore . . . . .	Oxides, silicates, some sulfides	Oxides, silicates, some sulfides	Sulfides	oxides, silicates, some sulfides
Ore preparation. . . . .	May be crushed to optimize copper recovery	May be crushed to optimize copper recovery	None: waste rock used	None, block caving, blasting
Container or pad . . . . .	Large impervious vat	Specially built impervious drainage pad	None for existing dumps; new dumps intended to be leached would be graded, and covered with an impermeable polyethylene membrane protected by a layer of select fill	None
Solution . . . . .	Sulfuric acid for oxides; acid cure and acid-ferric cure provide oxidant needed for mixed oxide/sulfide ores	Sulfuric acid for oxides; acid cure and acid-ferric cure provide oxidant needed for mixed oxide/sulfide ores	Acid ferric-sulfate solutions with good air circulation and bacterial activity for sulfides	Sulfuric acid, acid cure, acid-ferric cure, or acid ferric-sulfate, depending on ore type
Length of leach cycle . . . . .	Days to months	Days to months	Months to years	Months
Solution application method . . . . .	Spraying	Spraying or sprinkling	Ponding/flooding, spraying, sprinkling, trickle systems	Injection holes, spraying, sprinkling, trickle systems
Metal recovery method . . . . .	Solvent extraction for oxides; iron precipitation for mixed ores	Solvent extraction for oxides; iron precipitation for mixed ores	Solvent extraction for oxides; iron precipitation for mixed ores	Solvent extraction for oxides; iron precipitation for mixed ores

SOURCE Office of Technology Assessment, 1988; based on J. Brent Hiskey, "The Renaissance of Copper Solution Mining," Arizona Bureau of Geology, *Fieldnotes*, fall 1986,

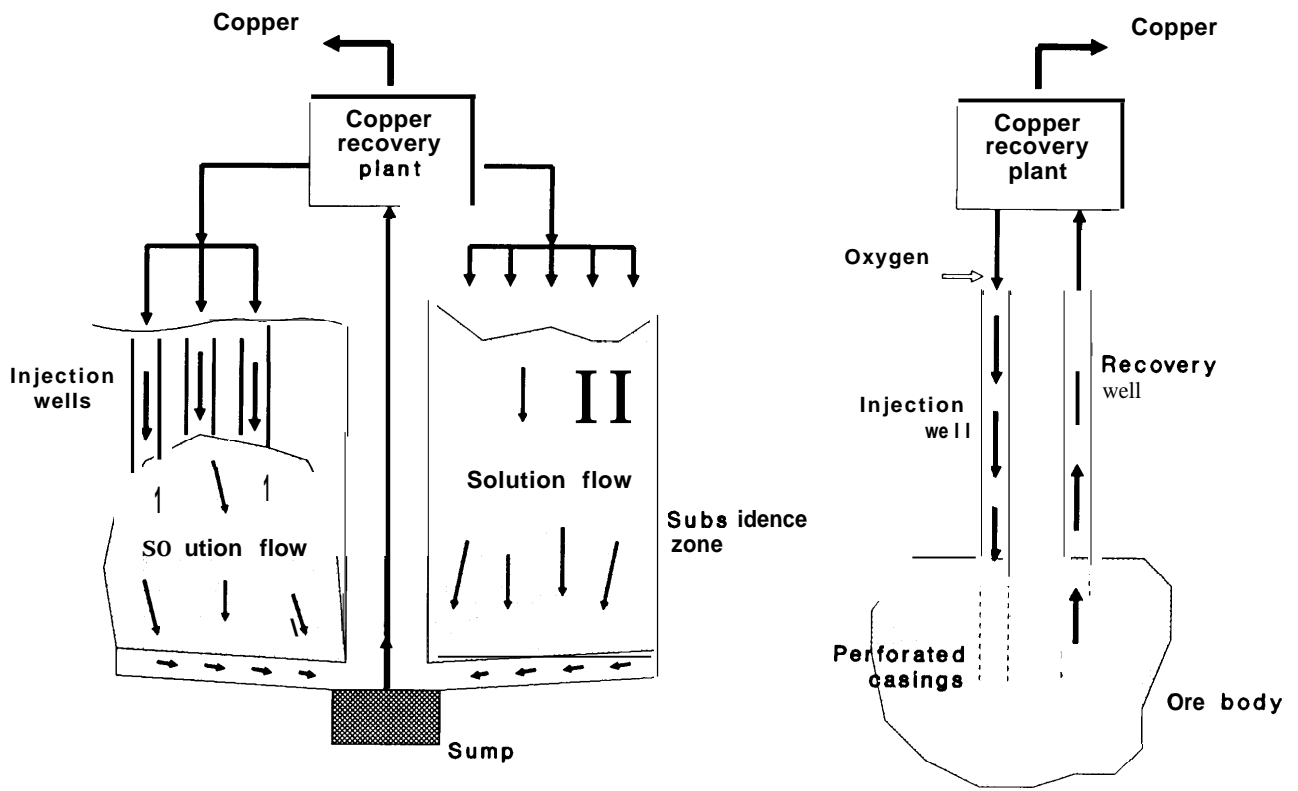


Figure 6-13.-Heap and Dump Leaching



SOURCE J Brent Hiskey, "The Renaissance of Copper Solution Mining," *Fieldnotes* Fall 1986

Figure 6-14.-Types of In Situ Leaching Systems



SOURCE: J. Brent Hiskey, "The Renaissance of Copper Solution Mining," Fieldnotes, Fall 1986

**Table 6-7.—Summary of in Situ Copper Mining Activities**

Mine	Cu produced (lb/day)	Average ore grade (%)	Principal Cu minerals	Ore preparation	Solution/ application	Solution recovery	Cu in solution (gpl)	Cu recovery method	Active dates
Big Mike (NV)	5,000 <sup>a</sup>	1.18	Cuprite, tenorite, chalcocopyrite	Blasted pit walls, terraced	Dilute H <sub>2</sub> SO <sub>4</sub> : sprinklers	Recovery well	2.0, then 0.8	Precipitation on scrap iron	1973-74. 1978-79
Bingham (UT)	20,000 <sup>b</sup>	0.3	Chalcocite	None, leached block-caved area	Water, launder	Tunnel	2.02	Precipitation on scrap iron	1922-? (now part of open pit)
Burro Mt. (NM)	NA	NA	Chalcocite	None, leached block-caved area	Water	Underground workings	NA	Precipitation on scrap iron	1941-49
Butte (MT)	33,000 <sup>b</sup>	0.8	Chalcocopyrite, chalcocite	None, leached backfilled slopes	Very dilute H <sub>2</sub> SO <sub>4</sub> : rejection	Tunnel	0.5-0.75	Precipitation on scrap iron	1930s-1964
Consolidated (NV)	NA	0.3	Sulfides	None, leached block-caved area	Water	Underground workings	1.0	Precipitation on scrap iron	1925-?
Copper Queen (AZ)	5,800 <sup>a</sup>	0.29	Chalcocite	None, leached pit and underground workings	Water; sprinklers	Underground workings	0.6	Precipitation on scrap iron	1975-present
Emerald Isle (AZ)	250 then 750 <sup>b</sup>	1.0	Chrysocolla	Blasted pit bottom	Dilute H <sub>2</sub> SO <sub>4</sub> , perforated pipe	Recovery wells	0.59, then 0.65	Precipitation on scrap iron	3/74-6/74, then 12/74-6/75
Inspiration (AZ)	5,200 <sup>b</sup>	0.5	Azurite, malachite, chrysocolla	None, leached block-caved area	Dilute H <sub>2</sub> SO <sub>4</sub> ; injection holes	Underground workings	1.8, then 0.7	Precipitation on scrap iron	1967-74
Kimbly (NV)	NA	0.32	Chalcocite	None	Dilute H <sub>2</sub> SO <sub>4</sub> ; injection	Recovery well	0.15b	NA	1970-71
Medler (AZ)	NA	0.38	Sulfides	None	Water; flooded drifts	Drifts	0.2-0.6	Precipitation on scrap iron	1906-09
Miami (AZ)	30,000-35,000 <sup>b</sup>	0.88 <sup>c</sup>	Chalcocite	Glory hole over block-caved area	Dilute H <sub>2</sub> SO <sub>4</sub> ; pipe spray and injection holes	Drifts	0.835	Precipitation on scrap iron, then SX-EW	1942-present
Mountain City (NV)	4,800 <sup>b</sup>	0.93-1.1	Chalcocite	Block caving	Dilute H <sub>2</sub> SO <sub>4</sub> ; injection wells	Drift	0.5-0.6	Precipitation on scrap iron	1974
Ray (AZ)	20,000 <sup>b</sup>	1.0	Chalcocite	None, leached block-caved area	Water, sprinklers	Drifts	9.23	Precipitation on scrap iron	1941-49
San Manuel (AZ)	NA	0.47-0.72	Chrysocolla, cuprite	None, leached block-caved area	Dilute H <sub>2</sub> SO <sub>4</sub>	Underground workings	NA	SX-EW	1986-present
Van Dyke (AZ)	NA	0.5	Chrysocolla	Wells drilled and hydrofraced	Dilute H <sub>2</sub> SO <sub>4</sub> , rejection well	Recovery well	NA	SX-EW	1976-80
Zonia (AZ)	5,000 <sup>a</sup>	0.2	Chrysocolla	Blasted pit walls and bottom	Dilute H <sub>2</sub> SO <sub>4</sub> , sprinklers	Recovery well in pit bottom	2.0, then 0.8	Precipitation on scrap iron	1973-75

NA = not available.

<sup>a</sup>Maximum.

<sup>b</sup>Design capacity.

<sup>c</sup>Original ore body; caved stopes unknown.

SOURCE: Jon K. Ahlness and Michael G. Pojar, *In Situ Copper Leaching in the United States: Case Histories of Operations* (Washington, DC: U.S. Department of the Interior, Bureau of Mines Circular IC 8981).

### Box 6-A.—The Lakeshore Mine In Situ Project

The Lakeshore Mine, near Casa Grande, Arizona, originally was a combination underground/leaching operation. Beginning in the mid-1970s, Hecla Mining Co. developed an underground operation in which sulfide ore was mined, crushed, and concentrated; copper sulfates were vat leached and electrowon; and oxide ores were vat leached and precipitated. Underground mining was very expensive because the surrounding rock was weak and the tunnels needed extraordinary support. Therefore, the mine shut down after around two years of operation.

Noranda purchased the property in 1979. Because of the problems with the ground, they focused on the larger oxide ore body, using block caving techniques. As the price of copper dropped, however, development of the deeper portions of the ore body became prohibitively expensive, and they began leaching the block caved areas, Noranda drilled injection holes through the caved areas, ran the solution into blocked off underground haulage drifts, and then pumped it to the surface.

As the remaining ore in these areas became depleted, Noranda developed a plan for in situ leaching of the deeper, virgin ore bodies. This plan involved injecting leach solution into the "solid" ore under pressure, with the assumption that the solution would rise to the zone of least pressure—the dammed drifts—through the recovery wells. With an oxide ore body averaging 1.5 to 3 percent copper, this scheme, if it worked, would provide 30 years of leach production.<sup>1</sup> The U.S. Bureau of Mines awarded a contract for study of in situ techniques at Lakeshore (as well as at a less developed property nearby) in 1986.

Cyprus Minerals purchased the property in mid-1987, changing the name to Cyprus Casa Grande. Cyprus hopes technologies for in situ leaching will enable it to exploit 50 million tons of oxide ore containing slightly less than 1 percent copper, or around 10 million lb/yr copper leach production from the rubblized ore.<sup>2</sup>

<sup>1</sup> Paul Musgrove, General Manager, Noranda Lakeshore Mine, personal communication to OTA, April 1986.

<sup>2</sup> "Cyprus Expands Operations via Lakeshore Acquisition," *Engineering & Mining Journal*, September 1987, at p. 19.

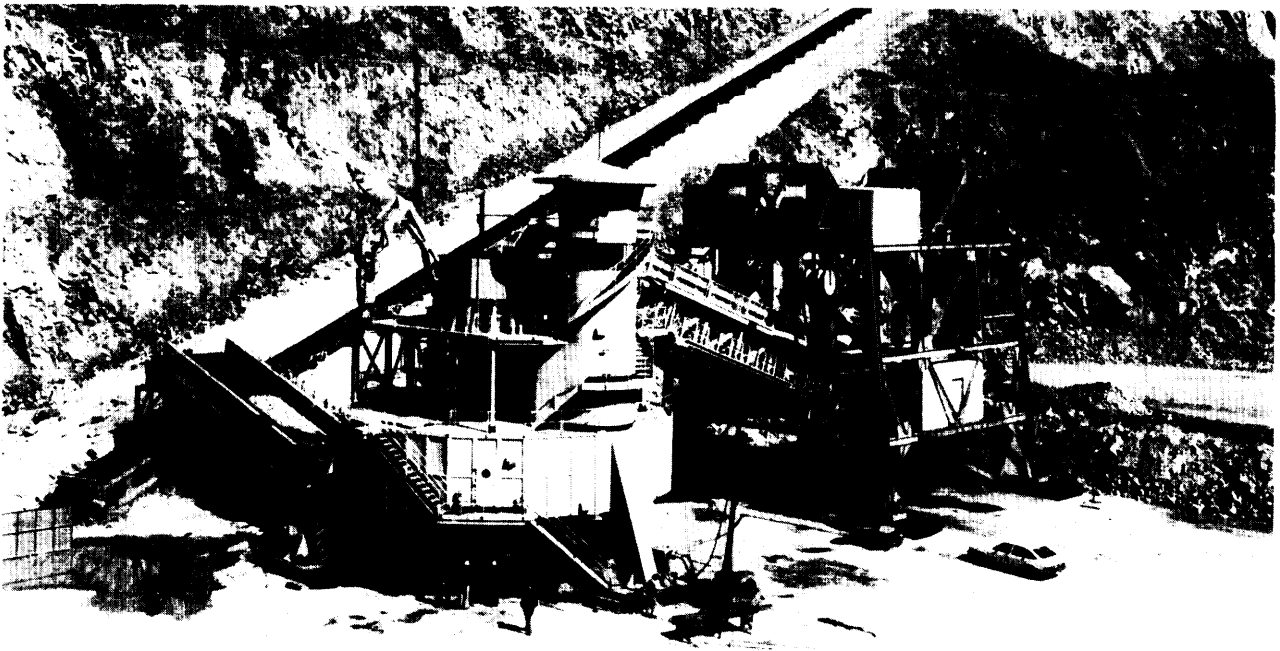


Photo credit: Manley-Prim Photography, Tucson, AZ

Crushing the ore in the pit and using conveyor belts to haul the crushed ore to the mill greatly reduces haulage costs.

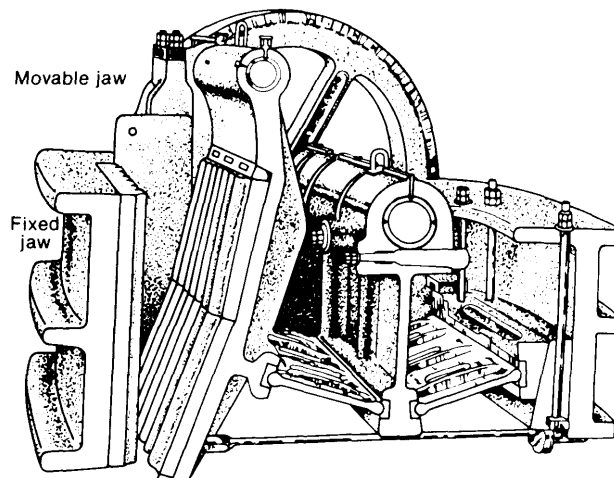
## COMMINUTION AND SEPARATION<sup>30</sup>

The first step in separating copper from other minerals in ore mined by underground or open pit methods is comminution (pulverization) of the ore chunks—essentially from boulders to grains of sand. (Mining is actually the first stage of size reduction, accomplished with explosives.) Primary, secondary, and tertiary crushing reduce the ore to about 25 mm, and grinding accomplishes finer reductions. Separators (e.g., screens, cyclones<sup>31</sup>) are used between stages to control the size of particles going on to the next stage. Together, comminution / separation and flotation/dewatering (beneficiation; see below), are known as milling.

In terms of time, energy, and materials used per tonne of copper produced, comminution is expensive because the ore is still very low in grade. Crushing and grinding consume around 33 to 40 percent of the total energy required to produce refined copper (see ch. 7).<sup>32</sup> There also are significant materials costs and downtime for maintenance. Dust control in mill buildings is another cost factor. **Therefore, improvements in the energy, materials, or operating efficiency of crushing could make a significant difference in production costs.** For example, autogenous<sup>33</sup> grinding, if technically feasible, could save around 10 to 20 cents per ton of ore milled.<sup>34</sup>

**Crushing** often is accomplished in jaw, gyratory, and cone crushers, which fracture rocks by compression (see figure 6-15). Jaw or gyratory crushers are usually used for the first stage (primary crushing), and cone crushers for secondary and tertiary crushing. The choice is determined by feed size (jaw crushers handle larger

Figure 6-15.—Jaw Crusher



SOURCE: Gordon L. Zucker and Hassan E. El-Shall, *A Guide to Mineral Processing*, Montana College of Mineral Science and Technology, Special Publication 85, 1982

pieces) and capacity (gyratory crushers handle 3 to 4 times more rocks of a given feed size). A pneumatic or hydraulic impact breaker (similar to a jackhammer) is used to break up rocks too large for the primary crusher.

The crushed ore is transported, usually on conveyor belts, to the grinding mills. Grinding mills can be operated wet or dry. In general, when subsequent processing is to be carried out wet (e.g., flotation), wet grinding is the logical choice. Wet grinding requires less power per tonne of ore, less space, and does not need dust control equipment. However, it uses more steel grinding media and mill lining material due to corrosion, and may be limited by the availability of water. If wet grinding is used, the crushed ore is mixed with water to form a slurry of around 40 percent solids.

**Grinding mills** work by tumbling the ore with steel rods or balls, or particles of the ore itself (autogenous and semi-autogenous grinding). Because the grinding media eventually wear down, new media must be added regularly. Mill liners, which cushion the mill shell, also wear away and must be replaced periodically. For liner replacement, the individual mill has to be taken out of

<sup>30</sup>Unless otherwise noted, the material in this section is from Errol G. Kelly and David J. Spottiswood, *Introduction to Mineral Processing* (New York, NY: John Wiley & Sons, 1982).

<sup>31</sup>A cyclone is a centrifugal device for separating materials according to weight or size.

<sup>32</sup>Charles H. Pitt and Milton E. Wadsworth, *An Assessment of Energy Requirements in Proven and New Copper Processes*, report prepared for the U.S. Department of Energy, contract No. EM-78-S-07-1743, Dec. 31, 1980.

<sup>33</sup>Autogenous or "self" grinding uses only pieces of ore as the grinding media. Semi-autogenous grinding uses a few large steel balls to break the ore down into intermediate size particles.

<sup>34</sup>A.K. Biswas and W.G. Davenport, *Extractive Metallurgy of Copper* (New York, NY: Pergamon Press, 1980).

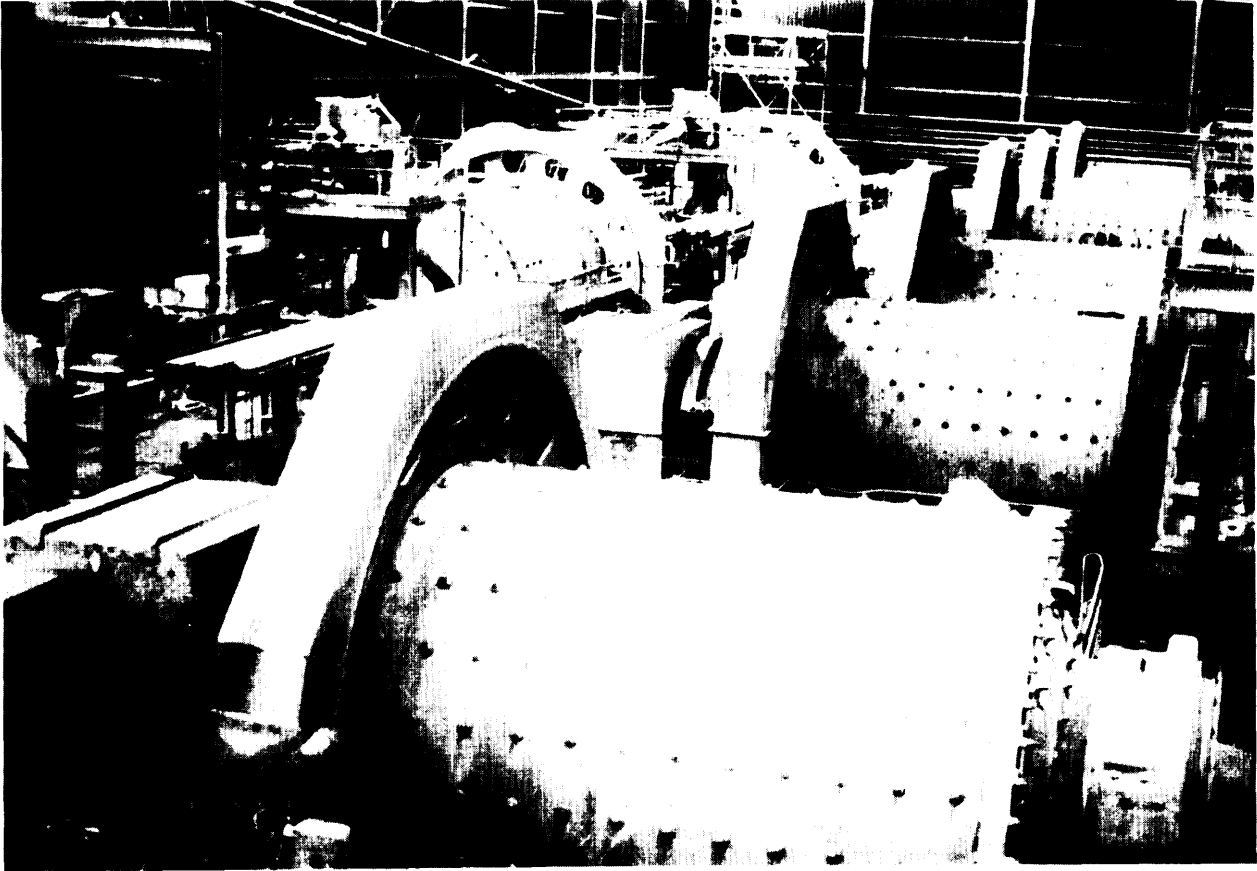


Photo credit: Jenifer Robison

Ore is tumbled in large cylindrical mills with steel balls or rods, or chunks of hard ore (autogenous grinding), until it is pulverized.

production. Even so, mills usually can achieve 99 percent operating time.

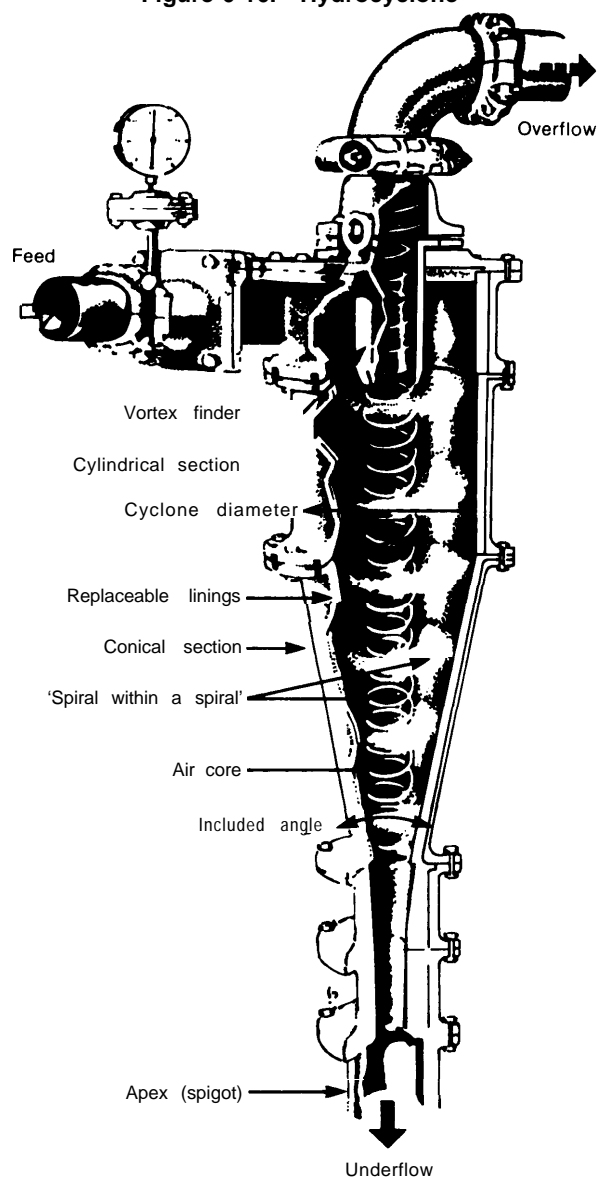
**Size separators control both the size of material fed to crushers or grinders and the size of the final product. Thus they control both under- and overgrinding.<sup>35</sup> There are two types of separators:**

<sup>35</sup>There is an Optimum mix between crushing and grinding. Any breakage produces a range of product sizes, and when the reduction ratio (feed size/product size, or amount of reduction achieved) is comparatively low, some of the feed is already as fine as the product of that or the next phase (e.g., fines that sift out of a primary crusher). By screening this material out and bypassing the next reduction stage, the size of the machine can be reduced because throughput is lower. Also, removal of finer particles will make the equipment more efficient by reducing cushioning effects inside the mill. Overgrinding also can be avoided by operating the final stages in closed circuit with high circulating loads, so that material is sized frequently and thus has little chance of being ground unnecessarily before it is removed from the circuit.

screens for coarse materials, and classifiers for fines. Screens separate ore sizes mechanically using a slotted or mesh surface that acts as a “go/no go” gauge. Classifiers are based on particles’ settling rate in a fluid (usually water). The hydrocyclone (figure 6-16) is the industry standard for classifying because of its mechanical simplicity, low capital cost, and small space requirements. Often the hydrocyclone gives relatively inefficient separations, however, resulting in recycling of some concentrates for regrinding and final concentration.

**Recent technological advances in comminution have increased the size and efficiency of both crushing and grinding equipment. instrumentation and controls have improved throughput rates and the consistency of particle size in**

Figure 6-16.—Hydrocyclone



SOURCE: Errol G. Kelly and David J. Spottiswood, *Introduction to Mineral Processing* (New York, NY: John Wiley & Sons, 1982).

crushing and grinding mills.<sup>36</sup> Size separation, in contrast, has seen few significant innovations since the basic screen was invented.

Research has improved the capacity, energy utilization, and availability of cone crushers,

<sup>36</sup>Biswas and Davenport, *Supra* note 34.

which make finer feed for ball mills. This has reduced the amount of grinding media consumed, and in some cases eliminated the need to use both rod and ball mills.<sup>37</sup> Autogenous and semi-autogenous grinding can eliminate the need for secondary and tertiary crushing, allow larger mill diameters, and reduce the amount of grinding media consumed. Autogenous mills already have lower maintenance and capital costs than conventional mills. However, they only operate efficiently within narrow ranges of ore grade and hardness of feed material. Before autogenous grinding can be used more widely, additional work is needed to develop an improved understanding of ore properties such as hardness, moisture content, and shattering characteristics; and to develop more durable mechanical/electrical components.<sup>38</sup>

**Areas that could especially benefit from R&D include: 1) better classification in closed circuit grinding, to avoid over- and undergrinding; 2) the use of pebble milling instead of autogenous or steel grinding media; 3) evaluation of optimal energy consumption in size reduction by trade-offs among blasting, crushing, grinding, and re-grinding; 4) evaluation of alternative grinding devices (such as attrition mills and the Schenert roller) that might have higher grinding efficiencies; and 5) stabilizing control strategies in grinding and classification.**<sup>39</sup> Solution mining (discussed previously) bypasses grinding, and often crushing, entirely; improvements in this area therefore would eliminate these costs.

<sup>37</sup>C.A. Rowland, "Innovations in Crushing and Grinding Technology," paper presented at the 1986 American Mining Congress International Mining Show, Las Vegas, NV, Oct. 5-9, 1986.

<sup>38</sup>Mineral Systems Inc., *supra* note 26.

<sup>39</sup>*Id.*

## BENEFICIATION

The second step in separating copper from other minerals in mined ore is beneficiation, or concentration. The purpose of concentration is to eliminate as much of the valueless material as possible to avoid further expense in materials handling, transportation, and smelting. Froth flotation is the prevalent concentration method in the copper industry; it separates the pulverized ore (containing around 0.6 to 2.0 percent copper) into concentrates (with 20 to 30 percent copper) plus tailings (wastes of 0.05 to 0.1 percent copper) .<sup>40</sup>

A flotation cell resembles a large washing machine (see figure 6-1 7) that keeps all particles in suspension through agitation. The ore is first conditioned with chemicals that make the copper minerals water repellent (hydrophobic) without affecting the other minerals.<sup>41</sup> Then air is bubbled up through the pulp; with agitation, the hydrophobic copper minerals collide with and attach to the air bubbles and float to the top of the cell. As they reach the surface, the bubbles form a froth that overflows into a trough for collection. The other minerals sink to the bottom of the cell for removal .<sup>42</sup>

The simplest froth flotation operation is the separation of sulfide minerals from waste oxide minerals (e. g., limestone, quartz). The separation of different sulfide minerals (e. g., chalcopyrite from pyrite) is more complex, because the surfaces of the minerals have to be modified so that the reagent attaches specifically to the mineral to be floated .<sup>43</sup>

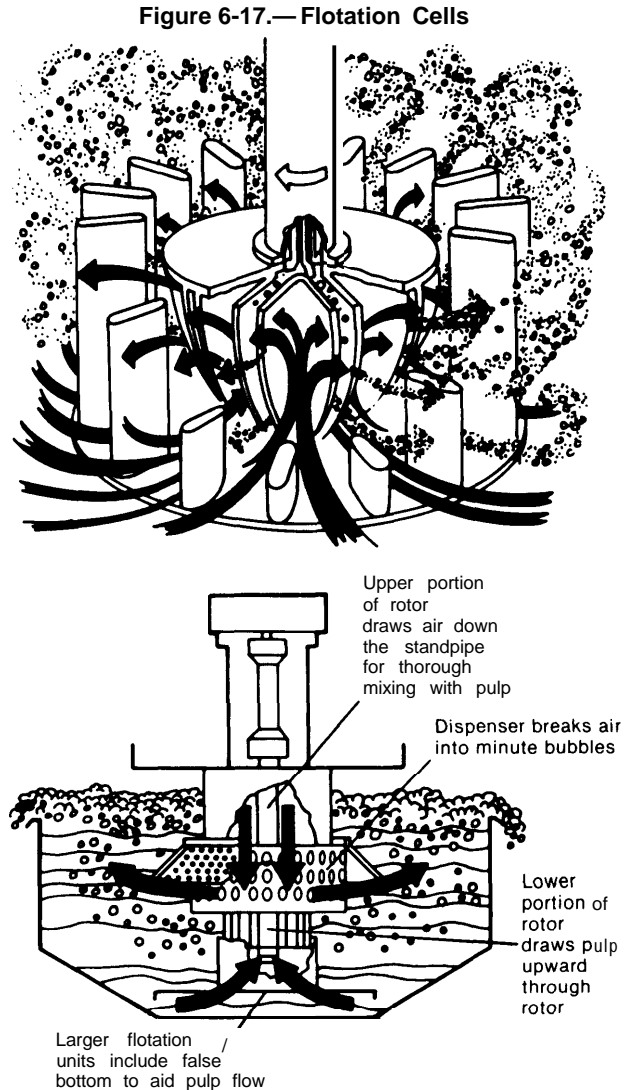
in practice, each ore is unique. Therefore there are no standard concentration procedures. A thorough knowledge of the mineralogy of the ore is essential for the design of a plant. Once a mill

<sup>40</sup>Biswas and Davenport, *supra* note 34.

<sup>41</sup> The principal chemical reagent used is the collector, which attaches (adsorbs) preferentially to the mineral to be recovered. To improve the degree of selective adsorption, other chemicals may be added to the slurry, including activators, which modify the surface properties of a mineral so that it becomes more amenable to flotation; depressants, which reduce the floatability of one or more mineral constituents; dispersion agents to help the selective reaction of other reagents; and pH regulators.

<sup>42</sup>Biswas and Davenport, *supra* note 34.

<sup>43</sup>*Ibid.*



SOURCE: Errol G. Kelly and David J Spottiswood, *Introduction to Mineral Processing* (New York, NY: John Wiley & Sons, 1982).

is in operation, continued appraisal of the mineralogy is critical to fine tuning to maintain efficiency. This arises because ore bodies are not homogeneous; variations in feed mineralogy are normal and may occur to such an extent that major circuit modifications are required.<sup>44</sup>

Conventional flotation is carried out in stages, the purpose of each depending on the types of

<sup>44</sup>Kelly and Spottiswood, *supra* note 30.





Photo credit: US. Bureau of Mines

In flotation, the copper attaches to bubbles and floats to the top, where it forms a froth that overflows into a trough for collection,

minerals in the ore (see figure 6-18). Selective flotation for copper sulfide-iron sulfide ores uses three groups of flotation cells (figure 6-1 8a):

- **roughers use a moderate separating force to float the incoming ore to produce a high copper recovery with a concentrate grade of 15 to 20 percent;**
- **cleaners use a low separating force** to upgrade the rougher concentrate by removing misplaced waste material, resulting in a final high-grade copper concentrate of 20 to 30 percent and;
- scavengers provide a final strong flotation treatment for the rougher tailings (with a large concentration of reagent and vigorous flotation) to recover as much copper as possible.

As shown in figure 6-1 8a, the tailings from the cleaner flotation and the “float” from the scav-

enger flotation (middlings) are returned to the start of the circuit. A regrind often is necessary for this to be effective. Alternatively, there may be a regrind between rougher and cleaner flotation,<sup>45</sup>

For more complex ores, the first stage often is a bulk float, similar to the rougher, in which much of the waste and some of the byproduct metals are eliminated (figure 6- 18b). The bulk concentrate then goes to roughers, which float the copper and eliminate the remaining metals, and then to cleaners. Again, there may be a regrind and second rougher cycle.<sup>46</sup>

The product of froth flotation contains 60 to 80 percent water, most of which must be removed before the concentrate can be transported or smelted. Dewatering is accomplished first by settling in large vats, known as thickeners. The solids settle by gravity to the bottom of the vat, where they are scraped to a discharge outlet by a slowly rotating rake.<sup>47</sup> Filters are used for final dewatering.

**Over the last 10 to 20 years, advances have been made in flotation chemicals, flotation cell design, and automated circuits.** Automated flotation monitoring and control systems improve metal recovery and reduce reagent consumption. Most U.S. operations have now installed these systems. Continued improvements in sensitivity would enhance the potential savings, however.

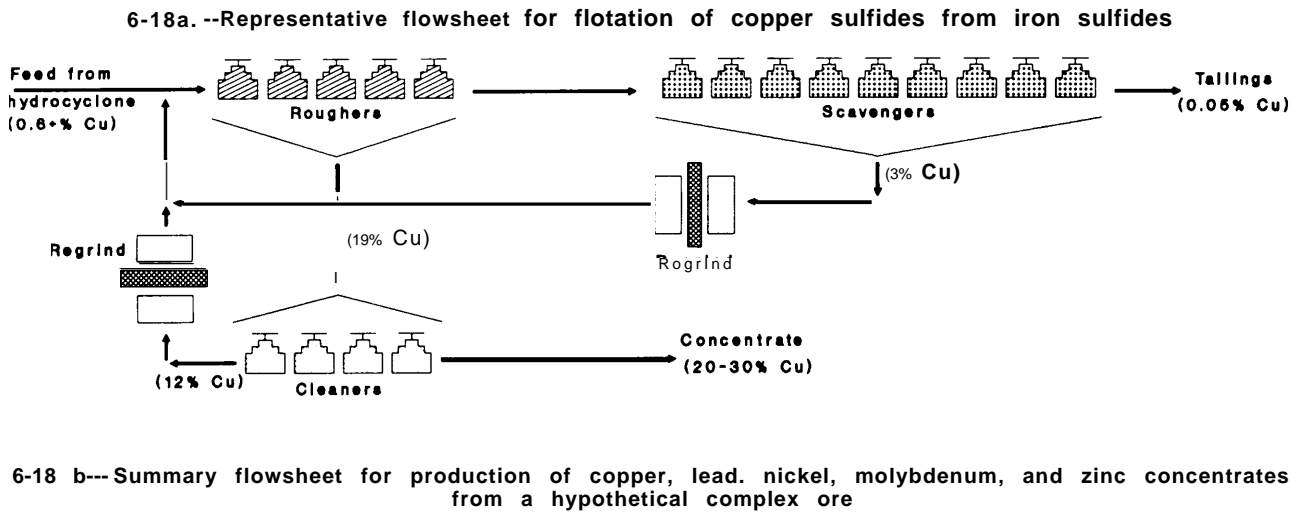
In flotation chemistry, a major development was the recognition that adsorption of sulfide minerals on air bubbles is an electrochemical process. Changing the electrochemical potential (by varying the chemical reagents) activates or depresses the various minerals, making them float or not float, and thus improves flotation efficiency. This offers significant savings—perhaps \$1 million annually—in reagent costs. Other potential benefits of electrochemical control include higher recoveries and lower operating costs. Even

<sup>45</sup>Biswas and Davenport, *supra* note 34.

<sup>46</sup>*ibid.*

<sup>47</sup>The liquid from the thickeners usually is recycled to the grinding and flotation circuits. This prevents adverse environmental impacts from the trace metals in the liquid (e.g., copper, arsenic, cadmium, lead, and zinc; see ch. 8). Water recycle systems also reduce water use, an important consideration in the arid regions where much of the world's copper is produced.

Figure 6-18.-Flowsheets for Copper Flotation



\* PbS may also be floated from copper sulfides  
 \* MoS<sub>2</sub> is floated off at this point.

SOURCE A K. Biswas and W.G Davenport, *Extractive Metallurgy of Copper* (New York, NY: Pergamon Press, 1980).

a 1 percent improvement in copper recovery (with no decrease in grade) could represent from \$1 million to \$5 million of additional income annually.<sup>48</sup>

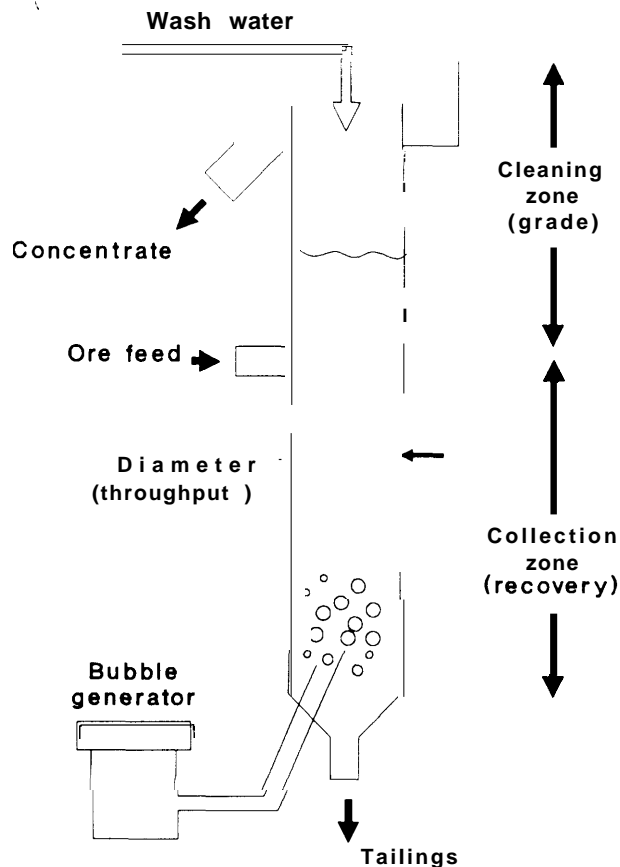
An important trend in cell design is the tendency toward larger cells. In the 1960s, newly installed cells had a volume of 3 or 4 cubic meters; today, flotation cells may have a volume of 85 cubic meters.<sup>49</sup> Experiments also are proceeding with the use of column cells, which use pneumatic agitation (see figure 6-19). Therefore

they can be more energy efficient and less costly to maintain than mechanical agitators. Other potential advantages of column cells include better recovery of fine particles (and thus fewer cleaning circuits), simpler control of electrochemical potential, and simpler automated process controls. Moreover, one column cell will replace several banks of mechanical flotation cells. Although these benefits have not been quantified, the improved recovery and capital and operating cost savings could add up to several millions of dollars annually. so

<sup>48</sup>Garret R, Hyde and Alexander Stojic, "Advances in Froth Flotation," paper presented at the 1986 American Mining Congress International Mining Show, Las Vegas, NV, Oct. 5-9, 1986.

<sup>49</sup>Biswas and Davenport, supra note 34.

Figure 6-19.-Column Cell



SOURCE J D McKay et al "Column Flotation," U.S. Bureau of Mines pamphlet, undated

Column cells already are used for molybdenum concentration, and are being tested in copper milling. Experience with a column cell at San Manuel, Arizona showed a concentrate grade of 29.83 percent copper with a sulfide copper recovery of 90.36 percent, compared to the conventional San Manuel flotation circuit with 29.99 percent copper in the concentrate and a recovery of 90.12 percent.<sup>51</sup>

<sup>51</sup>13. V. Clingan and D. R. McGregor, "Column Flotation Experience at Magma Copper Company," *Minerals and Metallurgical Processing*, vol. 4, No. 3, August 1987, p. 121.

## PYROMETALLURGY

Pyrometallurgical processes employ high-temperature chemical reactions to extract copper from its ores and concentrates.<sup>52</sup> These processes generally are used with copper sulfides and, in some cases, high-grade oxides. The use of high temperatures for metallurgical processing has several advantages: chemical reaction rates are rapid, some reactions that are impossible at low temperature become spontaneous at higher temperature, and heating the mineral to a liquid facilitates separation of the metal from the residue. Depending on the copper minerals and the type

<sup>52</sup> Pyrometallurgical processes typically operate at temperatures ranging from 500° C to 1250° C.

of equipment, pyrometallurgical recovery may take as many as four steps: roasting, smelting, converting, and fire refining.

Smelting is a relatively small component in the total cost of copper production—about 17 percent of gross U.S. production costs. In relative terms, however, the United States is least competitive in smelting. This is primarily attributable to high U.S. labor and energy costs. Thus, improvements in smelter labor productivity and energy efficiency would enhance domestic industry competitiveness. Domestic smelters also are at a disadvantage compared to some other coun-

tries due to the high level of environmental control required in the United States (ch. 10).

**Roasting prepares ores and concentrates** for either pyrometallurgical or hydrometallurgical processing. For the former, it dries, heats, and partially removes the sulfur and volatile contaminants (e. g., arsenic) from the concentrate to produce a calcine suitable for smelting. In hydrometallurgical processing, roasting converts sulfide minerals to more easily leachable oxides and sulfates.<sup>53</sup>

<sup>53</sup> Biswas and Davenport, *supra* note 34.

**In smelting**, concentrates or calcines are processed at high temperatures to produce a liquid copper-rich matte for converting, plus slag and sulfur dioxide ( $\text{SO}_2$ ). The heat required to melt the concentrate is generated from three sources: 1) retained heat from roasting, 2) external energy sources such as fossil fuels and electricity, and 3) the heat produced by the chemical combination of iron sulfides with oxygen. The slag is discarded, either directly or after further copper recovery in an electric furnace or flotation cell. The  $\text{SO}_2$  is captured for pollution control (see ch. 8).

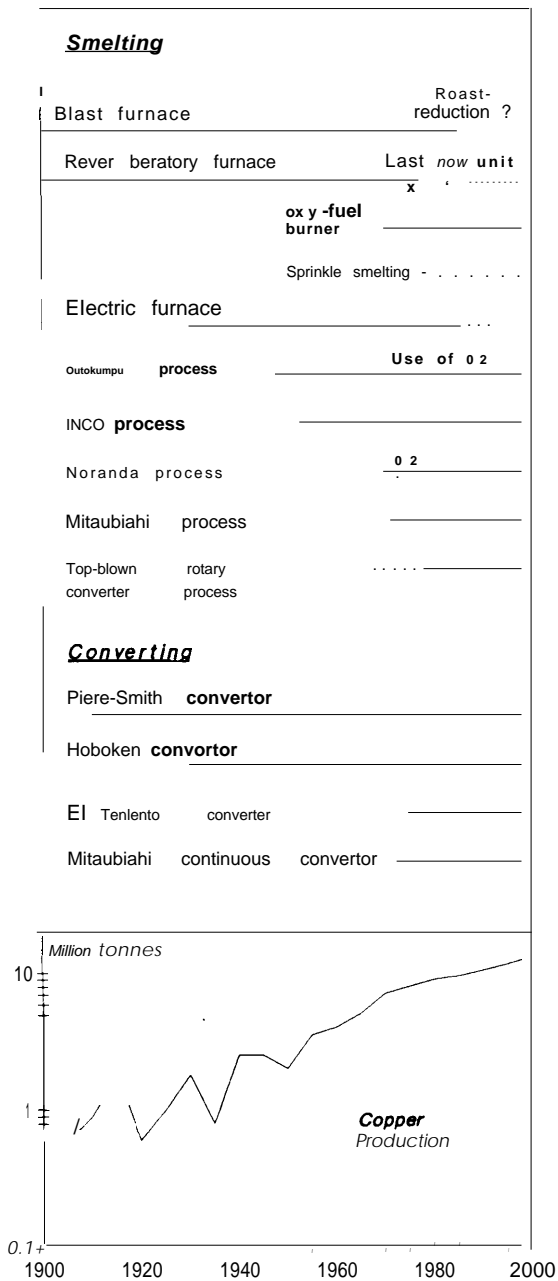
Figure 6-20 shows changes in smelting technology along with the increase in copper produc-



*Photo credit: Manley-Prim Photography, Tucson, AZ*

Tapping the smelter.

**Figure 6-20.-Development of Smelting Technology Compared with World Copper Production**



SOURCE United Nations Industrial Development Organization

tion. The earliest large-scale method of producing copper matte was in blast furnaces, which could handle ores containing 5 to 20 percent copper. With the decline in ore grades, direct smelt-

ing became too expensive, and the industry shifted to concentration followed by hearth or reverberatory smelting (see box 6-B). Flash furnaces, which combine roasting and hearth smelting and are more efficient than reverberatories, were introduced in the 1940s.

In recent years, concerns about the air quality impacts of reverberatory furnaces have led to the widespread adoption of electric and flash furnaces in the United States. As table 6-8 shows, almost all of the domestic smelters that are still operating upgraded their furnaces from reverberatories to more modern technology within the last 15 years. Most furnaces that were not upgraded were closed permanently (e.g., Phelps Dodge's Douglas, Morenci, and Ajo smelters; Kennecott's Ely and Ray smelters; Anaconda's Butte smelter; Asarco's Tacoma plant) .54

**Copper matte converting is the final stage in smelting; it usually is carried out in a Pierce-Smith converter (figure 6-25), which separates the matte into blister<sup>55</sup> copper (at least 98.5 percent copper) and slag. After the molten matte is poured into the converter, air is blown into the matte through nozzles (called "tuyeres"). First, the iron sulfide in the matte oxidizes into iron oxide and SO<sub>2</sub>; silica is added and the iron oxide forms an iron silicate slag, which is poured off after each blow. This leaves molten copper sulfide (white metal or chalcocite, Cu<sub>2</sub>S). The remaining sulfur in the white metal is then oxidized to SO<sub>2</sub>, leaving blister copper. Converter slags contain from 2 to 15 percent copper, and generally are recycled to the smelting furnaces, where their high iron content often serves as a smelting flux.<sup>56</sup>**

**Continuous production of blister copper has long been a goal of copper producers. Continuous reactors combine roasting, smelting, and converting in one operation that produces blister copper directly from concentrates, while taking advantage of the heat generated by the oxidation of sulfides. The benefits of continuous**

<sup>54</sup>The decline in domestic smelter capacity is discussed in ch. four.

<sup>55</sup>The term "blister" refers to the bumps on the surface of the copper created when the oxygen and sulfur that remain dissolved at high temperatures form gases when the copper is solidified.

<sup>56</sup>A flux is a substance that facilitates the separation of the smelter charge into matte and slag.

### Box 6-B.—Smelting Furnaces

The **reverberatory furnace** (figure 6-21) consists of a large, refractory-lined chamber. Fuel-fired burners melt the concentrates, forming an upper layer of slag (composed of iron silicate with less than 0.5 percent copper) and a lower layer of matte (30 to 45 percent copper). The reverberatory furnace was widely favored by the copper industry over the last 50 to 60 years because of its versatility; all types of material, lumpy or fine, wet or dry, could be smelted. However, the reverberatory furnace has relatively high fuel requirements, and its sulfur dioxide gas is too dilute for economic conversion into sulfuric acid or treatment with other pollution control methods (see ch. 8).

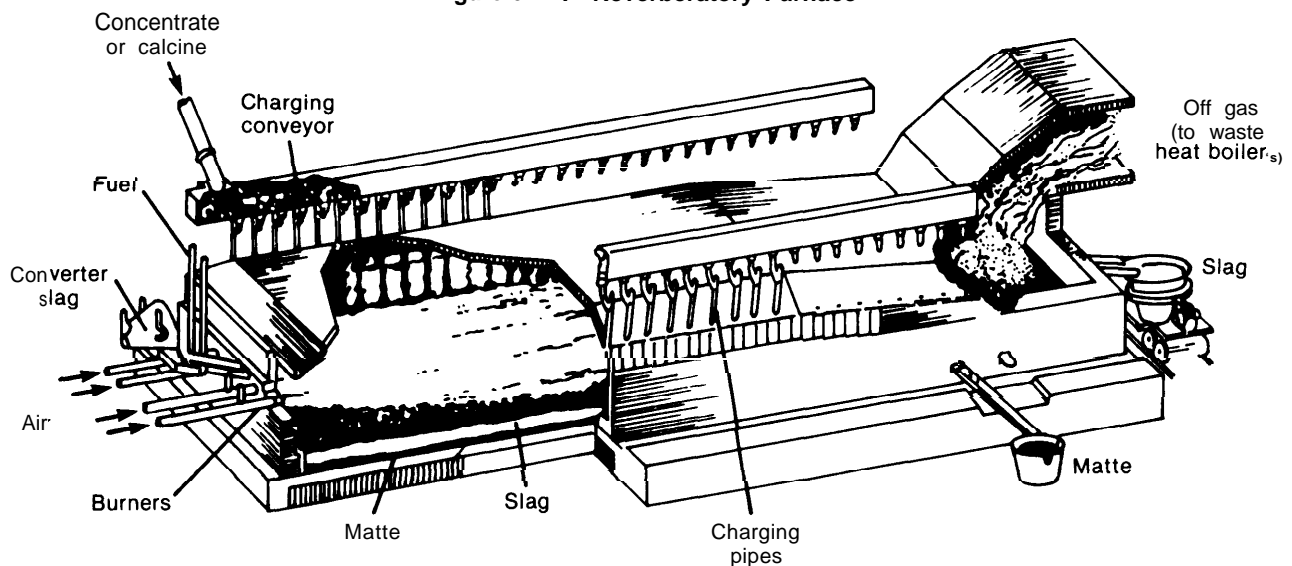
The **electric furnace** is an electrically heated hearth furnace (figure 6-22) that is similar in operation to the reverberatory furnace, but with more advantageous environmental control conditions for the effluent gases. The heat for smelting is generated by the flow of electric current between electrodes submerged in a slag layer. Although electric furnaces use electrical energy efficiently because of low heat loss, heat generation from sulfide oxidation is limited. The heavy reliance on external energy and the high price of electricity can result in relatively high energy costs,

In **flash furnaces**, concentrates are blown, together with oxygen or an air/oxygen mixture, into a hot furnace. The sulfide particles in the concentrates react quickly with the oxygen and combustion is extremely rapid. This produces enough heat to provide a large proportion of the thermal energy needed for smelting. As a result, flash furnaces have relatively low fuel costs. Their production rates also are high due to the rapid rate at which the mineral particles are heated, and the matte is relatively rich (50 to 75 percent copper). Further, their waste gases are rich in SO<sub>2</sub>, permitting economic pollution control. The principal disadvantage of flash furnaces is the high copper content of the slag (around 0.7 to 1.0 percent copper). This means that the furnaces cannot be used efficiently to recover copper from converter slags, and in some cases, the smelter slag must be recycled through the comminution and beneficiation plants.

There are two basic types of flash furnaces: 1) the INCO process (figure 6-23) uses commercial oxygen and requires no external energy (i.e., is autogenous); 2) the Outokumpu process (figure 6-24) uses pre-heated air or oxygen-enriched air. The Outokumpu flash furnace can be autogenous if the air is enriched to about 40 percent oxygen; otherwise it requires external fuel.

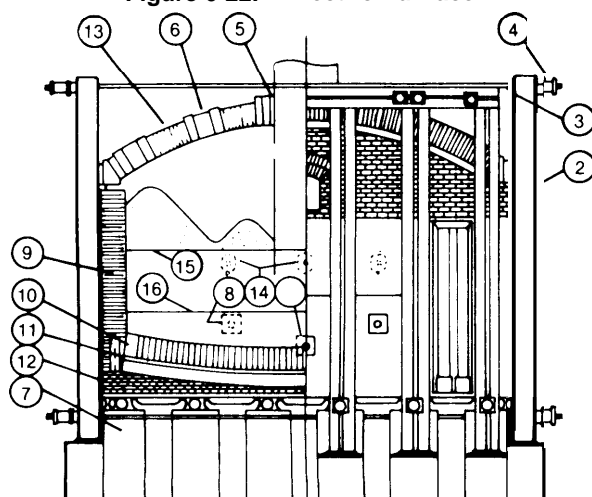
<sup>1</sup> Refractories are heat-resistant materials, usually made of ceramic.

Figure 6-21.—Reverberatory Furnace



SOURCE: McGraw Hill Encyclopedia of Science and Technology.

Figure 6-22.— Electric Furnace



## Legend

- |                                |                                    |
|--------------------------------|------------------------------------|
| 1. Drain out taphole           | 10 Magnesite hearth and sub-hearth |
| 2. Buckstay                    | 11 Magnesite castable              |
| 3. Tie-rod                     | 12 Fire-clay bricks                |
| 4. Tie-rod spring              | 13 Firebrick roof                  |
| 5. Electrode openings          | 14 Slag tapholes                   |
| 6. Furnace inspect ion ports   | 15 Average slag level              |
| 7. Furnace support pillars     | 16 Average matte level             |
| 8. Matte tapping blocks        |                                    |
| 9. Magnesite refractory bricks |                                    |

SOURCE A K Biswas and W G. Davenport, *Extractive Metallurgy of Copper* (New York, NY Pergamon Press, 1980)

blister copper production include lower capital cost, reduced materials handling, low heat losses, very low energy requirements, economical SO<sub>2</sub> gas recovery, and the ability to apply online computer controls to the entire copper-making process.

Two types of continuous reactors are in limited use: the Noranda process and the Mitsubishi process. The Noranda reactor (see figure 6-26) is a single-step process that always contains three liquid phases—slag, matte, and blister copper. The Mitsubishi reactor (figure 6-27) has three interconnected furnaces through which matte and slag flow continuously by gravity.

Neither of these processes has yet proven to be truly continuous. First, the slag contains as much as 10 percent copper. Slag from the Noranda reactor is recycled through comminution and beneficiation. Mitsubishi slag is reprocessed in the intermediate electric settling furnace. Sec-

ond, the blister copper from the Noranda reactor contains more impurity metals (e. g., antimony, arsenic, bismuth) than blister produced by conventional smelting/converting. This requires either more expensive electrorefining or the restriction of single-step continuous smelting to rather pure concentrates. Third, while the Noranda reactor operates more efficiently with oxygen-enriched air, oxygen levels above about 30 percent greatly increase equipment wear. As a result, the Noranda reactor typically is used to produce a very high-grade matte (70 to 75 percent copper), which is then treated in a converter.

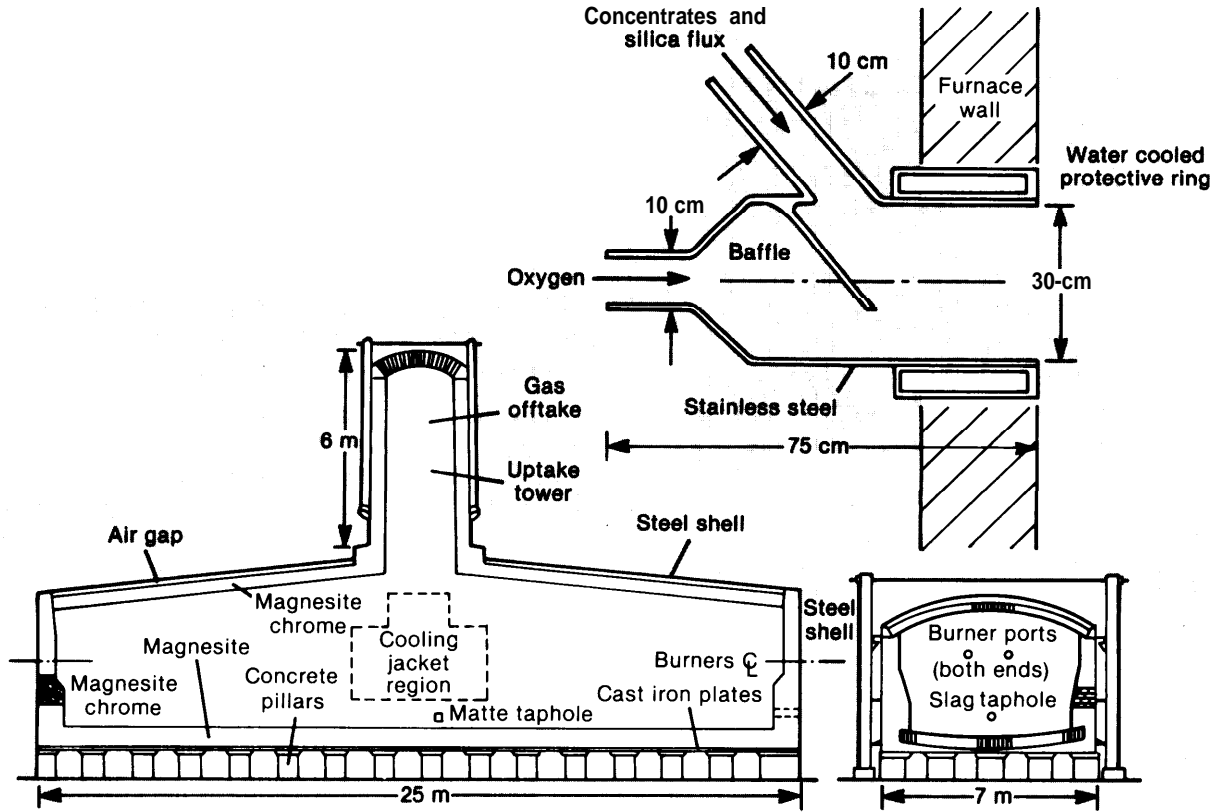
**Fire refining** further purifies blister copper to produce anodes pure enough for electrorefining. The residual sulfur is removed by blowing air through the molten blister (in a furnace similar to a Pierce-Smith converter) to form SO<sub>2</sub>, until the sulfur content has been lowered to 0.001 to 0.003 percent. The oxygen is then removed by blowing natural gas or propane through the tuyere until oxygen concentrations have dropped to 0.05 to 0.2 percent.

The molten copper is then poured into an anode casting wheel—a circular arrangement that is rotated to bring the molds under the furnace mouth. The anodes are cooled with water sprays as the wheel rotates. The critical parameters in anode casting are smoothness, straightness, and uniform thickness to ensure efficient electrorefining.

**Recent improvements in pyrometallurgical processing of copper concentrates** have focused on reducing energy requirements (see ch. 7) and on producing fewer gaseous emission streams with higher SO<sub>2</sub> concentrations for more cost-effective air pollution control (ch. 8). Better quality control of the product to reduce materials re-handling also has been a factor. Most domestic smelters now have on-line computer controls for greater throughput with better matte quality and almost automatic operation.

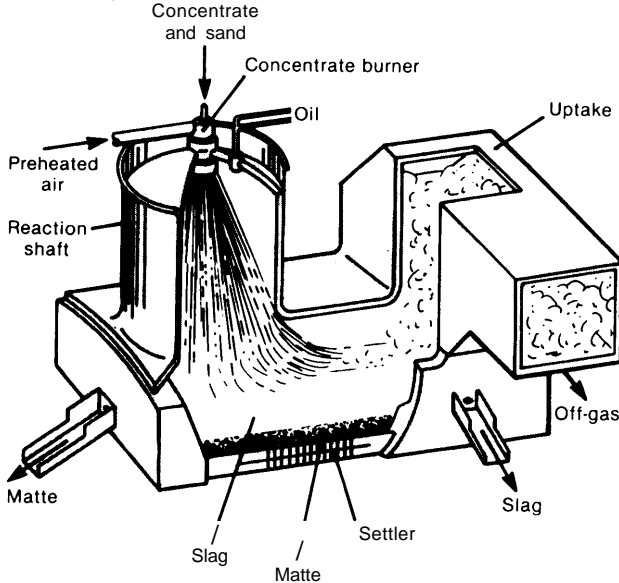
**One area in which further improvements would greatly assist the United States is continuous smelting**, because it would decrease materials handling and therefore increase labor productivity, would decrease energy use, and

Figure 6-23.—INCO Flash Furnace



SOURCE: A.K. Biswas and W.G. Davenport, *Extractive Metallurgy of Copper* (New York, NY: Pergamon Press, 1980).

Figure 6.24.—Outokumpu Flash Furnace



SOURCE: McGraw Hill Encyclopedia of Science and Technology.

Table 6.8.—Smelter Technology in the United States

Smelter	Type
Hayden (Arizona)	INCO flash furnace
Inspiration (Arizona)	Electric furnace
Morenci (Arizona)*	Reverberatory furnace
San Manuel (Arizona)	Outokumpu flash furnace
White Pine (Michigan)	Reverberatory furnace
Hidalgo (New Mexico)	INCO flash furnace
Hurley (New Mexico)	INCO flash furnace
Great Falls (Montana)*	Electric furnace
Copperhill (Tennessee)*	Electric furnace
El Paso (Texas)	Reverberatory furnace
Garfield (Utah)	Noranda reactor

\*Not operating.  
SOURCE: Office of Technology Assessment, 1988.

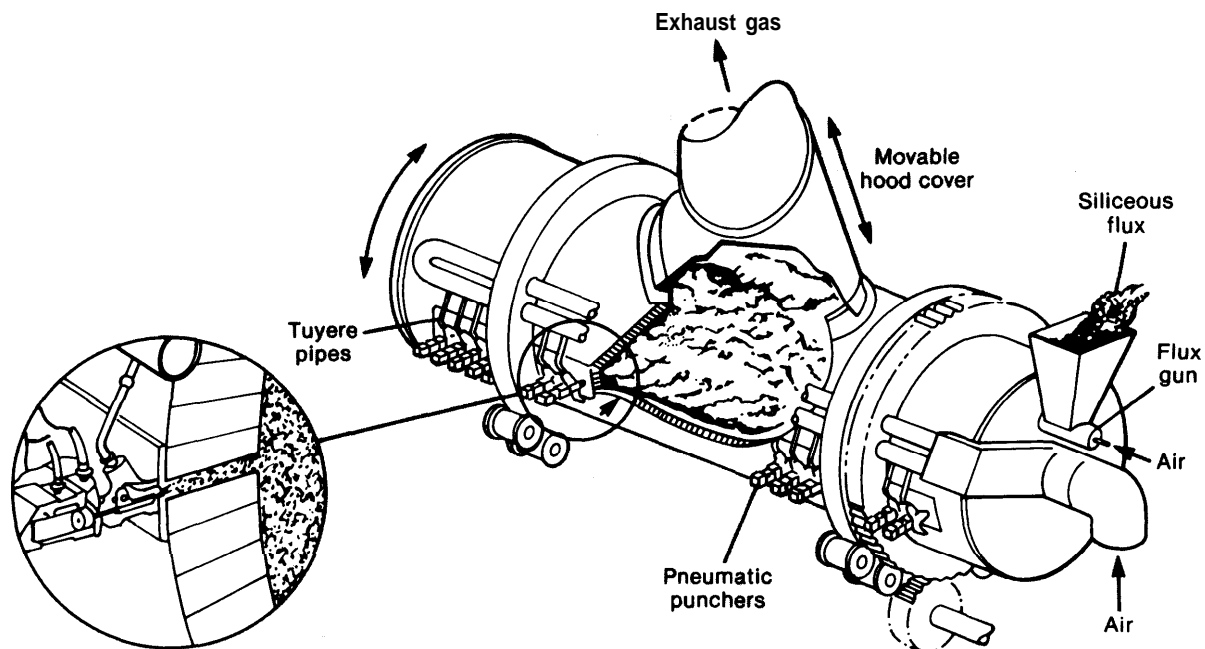
would make environmental control more cost-effective. However, installation of an entirely new smelting system has a high capital cost. Because most U.S. smelters already installed new furnaces within the last 15 years, it is unlikely that they



would undertake another such investment without a clear demonstration of substantial cost advantages, and without a very favorable business

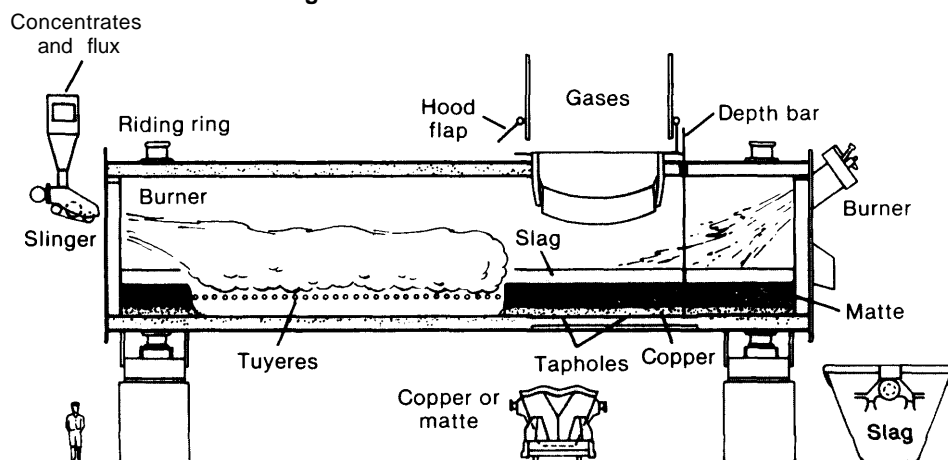
climate. Instead, U.S. companies will increase the proportion of copper they produce with hydro-metallurgical methods

Figure 6-25.—Pierce Smith Converter



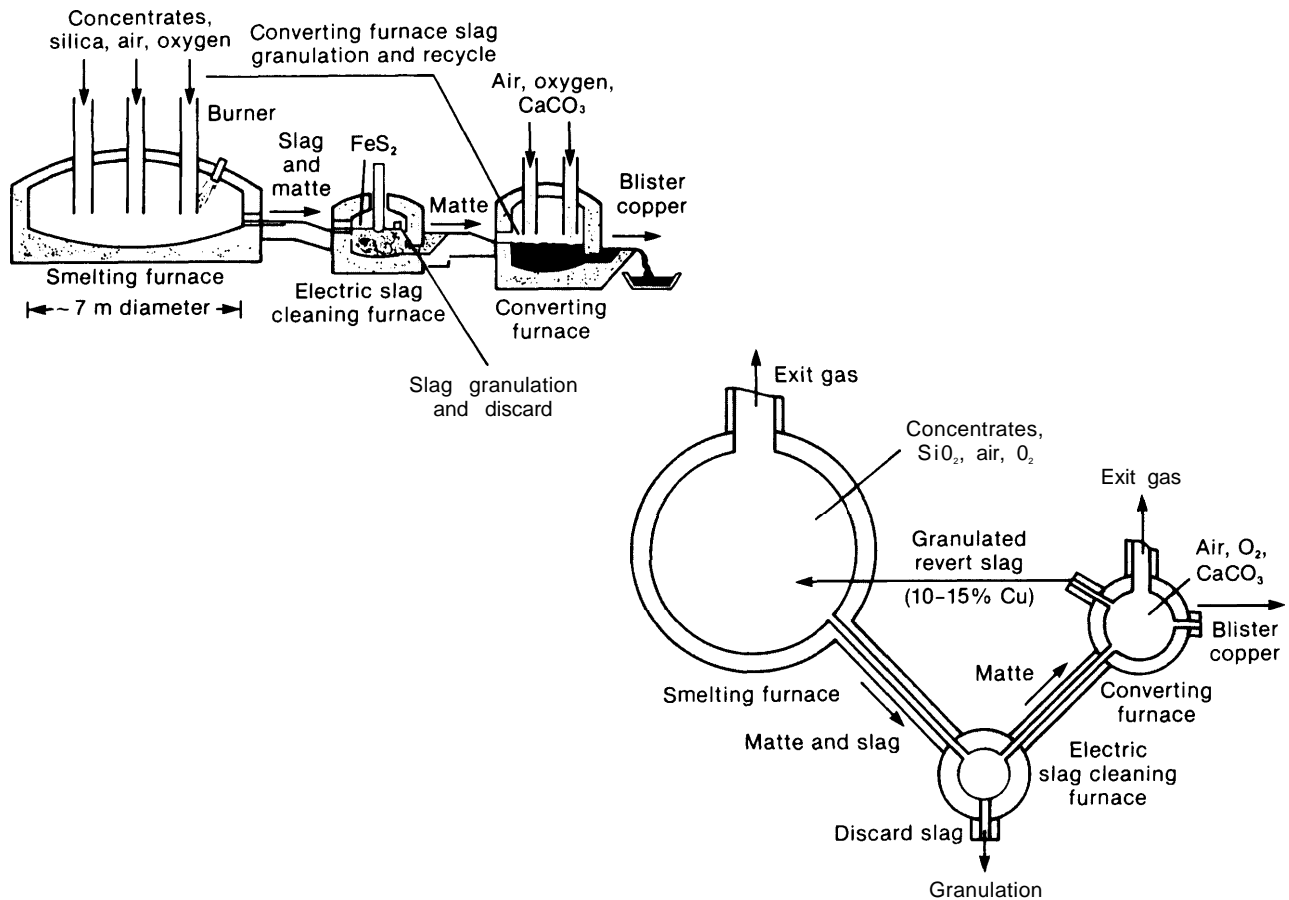
SOURCE: McGraw Hill Encyclopedia of Science and Technology

Figure 6.26.—Noranda Reactor



SOURCE: McGraw Hill Encyclopedia of Science and Technology

Figure 6-27.—Mitsubishi Continuous Smelting System



SOURCE: McGraw Hill Encyclopedia of Science and Technology.

## HYDROMETALLURGY

Hydrometallurgical copper recovery is the extraction and recovery of copper from ores using aqueous (water-based) solutions. Hydrometallurgical processes are applied mainly to oxide ores, and to low-grade oxide and sulfide mine wastes. As discussed in the section on mining, above, and in chapter 4, about 25 percent of domestic copper production is now through the use of solution mining techniques. Once the ore has been leached, the copper is recovered from the pregnant leachate through precipitation or solvent extraction.

<sup>57</sup>Chemical solutions also can be used to process copper concentrates. While several of these solutions are commercially available, their materials and energy costs are higher than for conventional smelting or leaching (see ch. 7).

These processes have several advantages over pyrometallurgical copper recovery methods, including the ability to treat lower grade ores (even waste dumps) economically, flexibility in scale of operations, simplified materials handling, and good operational and environmental control. Copper can be produced from dump leaching plus solvent extraction and electrowinning for around 30 cents per pound.<sup>58</sup> This is a clear cost advantage over pyrometallurgical production.

Solvent extraction is still largely confined to copper oxides. Hydrometallurgical techniques for

<sup>58</sup>Edward E. Malouf, "New Developments in Hydrometallurgy," paper presented at the American Mining Congress Mining Convention, San Francisco, CA, Sept. 22-25, 1985.

sulfides and complex ores are being developed. These will greatly aid the United States in overcoming its low ore grade disadvantage. It should be made clear, however, that dump leaching—exploitation of low-grade mine wastes—is primarily a means of lowering average production costs. It is not a substitute for conventional copper production by pyrometallurgical or other leaching methods.

In **iron precipitation**, or cementation, the pregnant leach solution flows through a pile of scrap iron/steel, and the copper precipitates onto the steel surfaces. Precipitation works through an electrochemical reaction: there is a transfer of electrons between the iron, which dissolves into

the solution, and the copper, which precipitates out of the solution. Cement copper detaches from the steel surfaces as flakes or powder under the force of the flowing solution. There are numerous precipitator designs and configurations (see, for example, the Kennecott cone precipitator shown in figure 6-28).

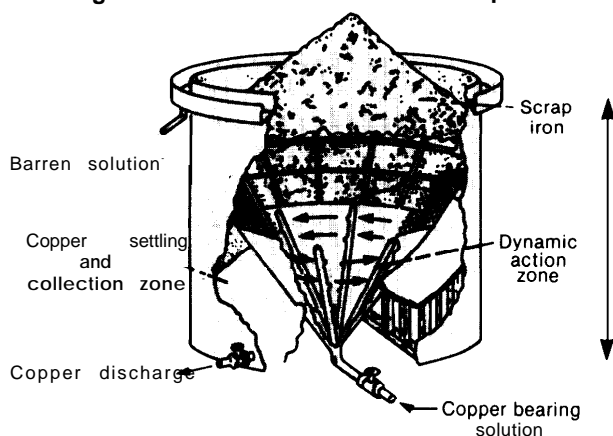
The principal advantage of precipitation is that virtually all of the copper is recovered from the leachate. Cement copper is still relatively impure, however, and subsequent treatment is required, usually through normal smelting/refining. Typically, cement copper contains around 85 to 90 percent copper, 0.2 to 2 percent iron, plus trace amounts of silica and aluminum oxides, and oxygen.



*Photo credit Manley-Prim Photography, Tucson, AZ*

A solvent extraction-electrowinning plant. The pregnant leachate flows to the collection ponds upper left). The solvent extraction tanks are shown at center, and the electrowinning plant at lower right.

Figure 6-28.—Kennecott Cone Precipitator



SOURCE: A K. Biswas and W.G. Davenport, *Extractive Metallurgy of Copper* (New York, NY: Pergamon Press, 1980).

In solvent extraction, an organic chemical that dissolves copper but not impurity metals is mixed with the pregnant leachate from solution mining. The copper-laden organic solution is separated from the leachate in a settling tank. Sulfuric acid

( $H_2SO_4$ ) is then added to the pregnant organic mixture, which strips the copper into an electrolytic solution for electrowinning (see below).

Solvent extraction is advantageous in that the electrolyte has almost no impurities and few environmental problems. Solvent extraction also makes relatively efficient use of the various solutions used: the spent leachate is returned to the leaching operation, the barren solvent is recycled to the pregnant leachate, and the spent electrolyte to the loaded solvent (see figure 6-29).<sup>59</sup>

New developments in hydrometallurgy have resulted primarily from a better understanding of the chemical and biological processes that occur in leaching; from improved heap and dump construction methods that speed up the leaching process; from automated controls and improved solvent recycling rates in solvent extraction; and from advancements in electrowinning (see below).

<sup>59</sup>Biswas and Davenport, *supra* note 34.

## ELECTROMETALLURGY<sup>60</sup>

Electrometallurgy deals with the use of electricity to refine metals. Virtually all primary copper receives electrolytic treatment, either through electrorefining of copper anodes or electrowinning of solvent extraction solutions. In essence, an electric current is used to bring about chemical changes that extract (electrowin) or purify (electrorefine) the copper.

Refining is the stage of copper production in which the United States is most cost competitive. This is due in part to low delivery costs and in part to major improvements in refinery labor productivity. More widespread use of automated controls and materials handling systems should enhance our refining cost position further. Because refining is only around 8 percent of the total cost of copper production, however, it provides little leverage in overall competitiveness.

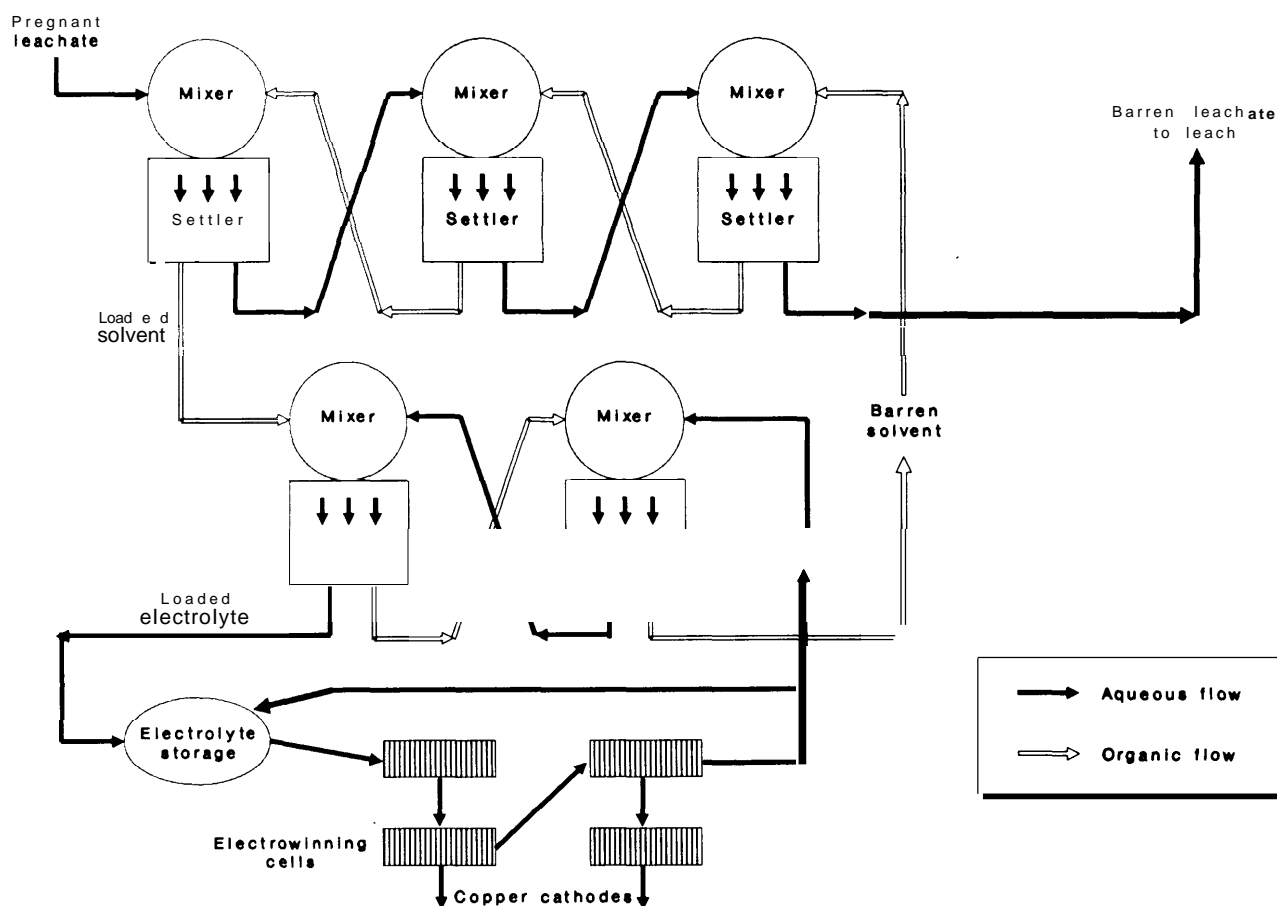
Electrorefining virtually eliminates the oxygen, sulfur, and base metals that are harmful to copper's properties (e.g., reduce its electrical conductivity) and decrease its value. At the same time, electrorefining allows the recovery of valuable impurities such as gold and silver. The end product, cathode copper, is 99.99+ percent pure, with less than 0.004 percent metallic and other impurities (including sulfur).

In electrorefining, the fire-refined copper anodes are hung vertically in between cathode starter sheets in long tanks, or cells, filled with an acidic copper sulfate solution. Usually the cathode starter sheets are themselves thin pieces of copper, which become incorporated into the cathode. An electric current is run through the solution and the copper gradually corrodes from the anode and plates onto the cathode. The cathode copper is shipped to the rod mill or fabricator for melting and casting.

Electrowinning is the recovery of copper from the loaded electrolyte solution produced by sol-

<sup>60</sup>The material in this Section is from Biswas and Davenport, *Supra* note 34, unless otherwise noted.

Figure 6-29.-Flowsheet for Solvent Extraction



SOURCE: A. K. Biswas and W.G. Davenport, *Extractive Metallurgy of Copper* (New York, NY: Pergamon Press, 1980).

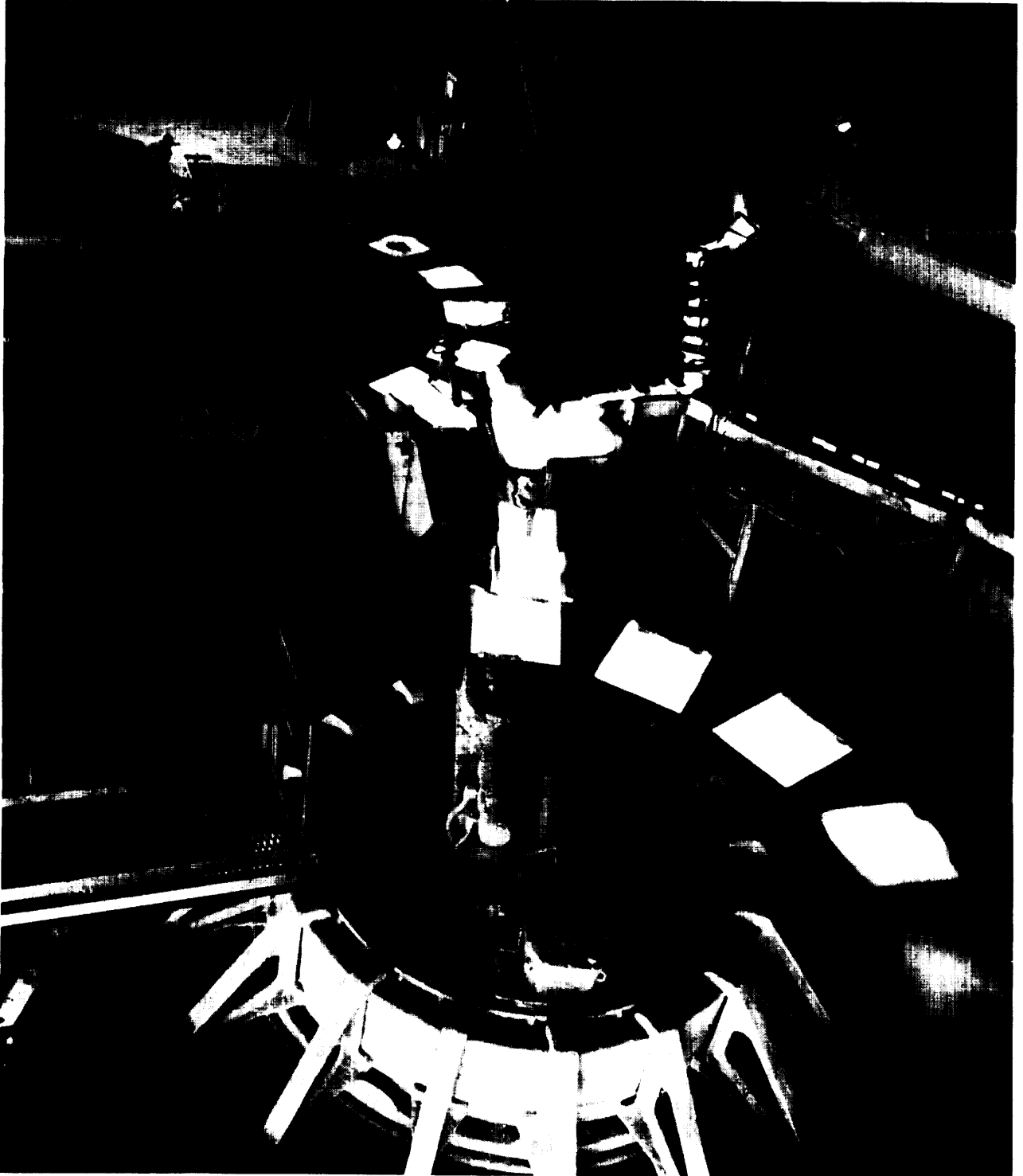
vent extraction. The basic difference between electrowinning and electrorefining is that in the former, the copper is already in the electrolyte. Therefore, electrowinning uses inert (non-dissolving) anodes, typically made of lead alloyed with calcium and tin, or of stainless steel. These react electrochemically to produce oxygen gas and sulfuric acid. The cathode copper is stripped from the starter sheets (which are reused), and then shipped to the rod mill or fabricator. The acid is recycled to the leaching operation. The cells and electrical circuitry are otherwise similar to those used in electrorefining, although voltages are higher.

**Recent innovations in electrorefining and electrowinning** have focused on increased produc-

tivity through automation and periodic current reversal. Automation of electrometallurgy operations includes computer monitoring of cell voltages, infrared scanning of cells to locate and correct short-circuits, robotic cathode stripping, programmable robotic cranes for automated anode and cathode handling, and machine straightening of cathode starter sheets.<sup>61</sup> Periodically reversing the direction of the direct current for a brief period can increase refinery capacity by as much as 15 percent.<sup>62</sup>

<sup>61</sup> Mineral Systems Inc., *supra* note 26.

<sup>62</sup> Biswas and Davenport, *Supra* note 34.



*Photo credit: Manley-Prim Photography, Tucson, AZ*

Anode casting wheels.

## MELTING AND CASTING

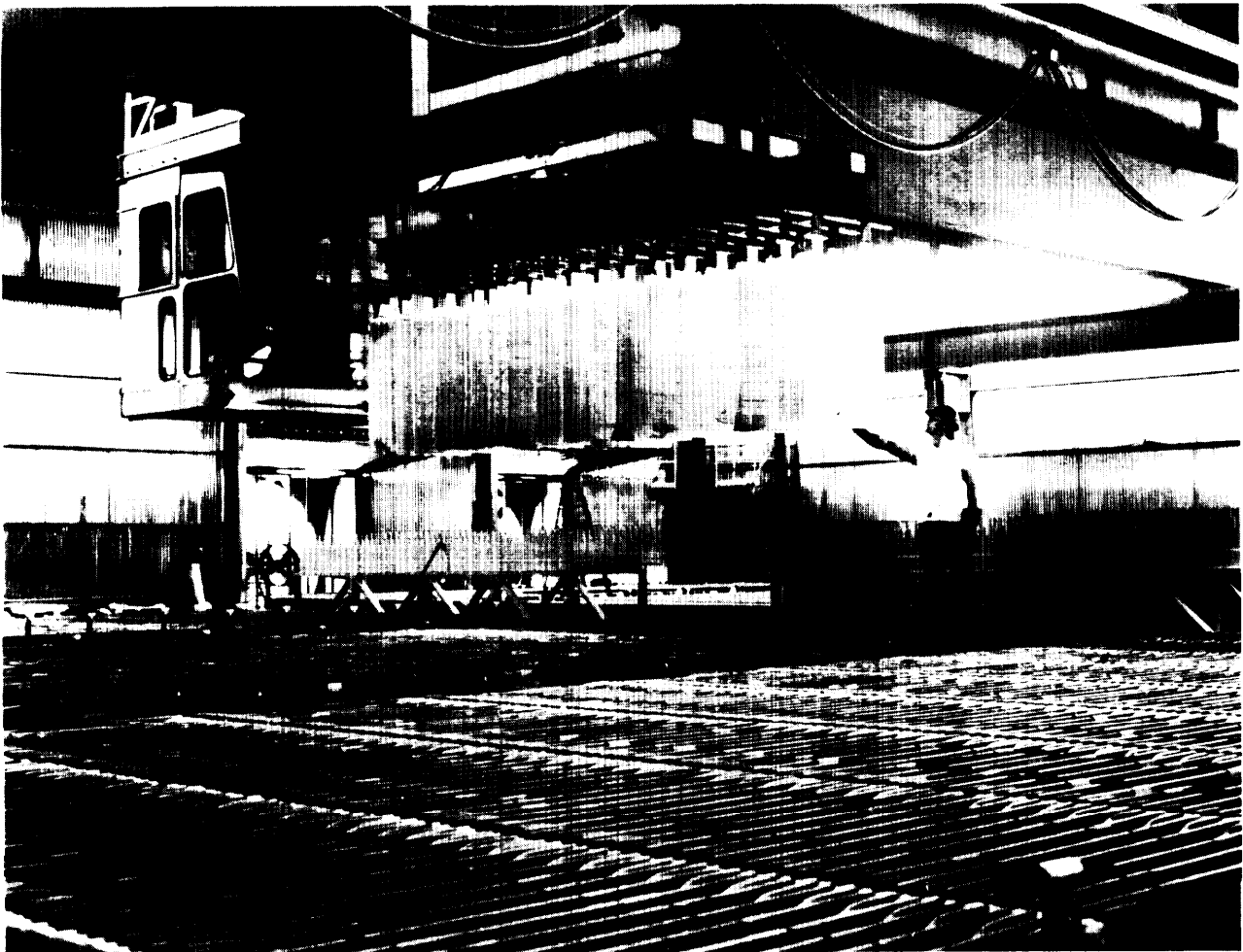
Cathode copper is melted and cast into continuous rod or wirebars for wire manufacture, into slabs or billets for mechanical use, or ingots for alloying. The three major forms of copper are:

- **electrolytic tough pitch copper** (less than 0.001 percent sulfur, 0.0015 to 0.03 percent oxygen) for wire and other electrical uses;
- **phosphorus deoxidized copper** (begins with a 90 percent copper and 10 percent phosphorus alloy, removes the oxygen as  $P_2O_5$ , leaving 99.95 to 99.99 percent copper and 0.01 to 0.05 percent phosphorus) for plumbing, radiators, and other uses requiring welding; and

● **oxygen-free copper**, which combines the high electrical conductivity of electrolytic tough pitch copper and the weldability of phosphorus deoxidized copper, for finely-drawn wire and electronic components.

The cathodes typically are melted in a shaft furnace. They are placed in an opening near the top of the furnace and melt as they descend the shaft. The liquid copper flows immediately into a separate gas-fired or induction-heated holding furnace, and then to casting.

Most mills making electrolytic copper now use continuous casting machines that integrate the



*Photo credit Manley Prim Photography, Tucson, AZ*

Cathode starter sheets above the electrorefining cells.

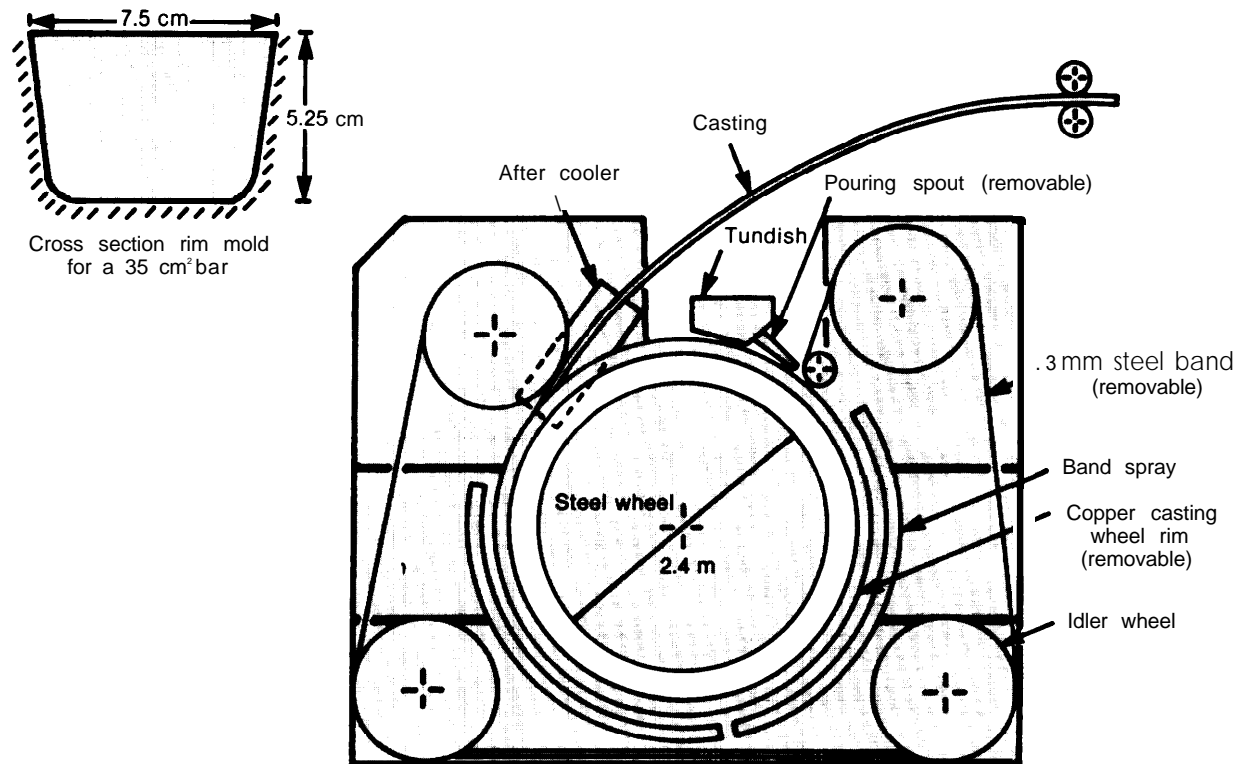
casting and subsequent fabrication of 5/16-inch rod in one continuous operation. In the continuous casting wheel patented by Southwire Corp., the liquid copper is poured onto a wheel with a bar-shaped well in the rim (figure 6-30). As the wheel turns, a belt covers the copper and it is partially cooled with a water spray. It exits the other end of the wheel as a red-hot but solidified continuous bar that then enters a single-pass rod-rolling mill (see figure 6-31). In the mill, the bar is extruded in several stages until it is the required thickness. When nearly cool, it is coiled automatically.

Before shipping to customers, the rod is tested in a metallurgy lab for surface quality, electrical

conductivity, chemical composition, and physical properties such as hardness, tensile strength, and elongation failure. Any batch that does not meet standards is remelted and recycled through the rod mill.

Continuous cast rod—now the industry standard—brought substantial improvements in productivity in melting and casting, through both automation and significant increases in the quality of the final product and thus fewer batches that have to be reprocessed.

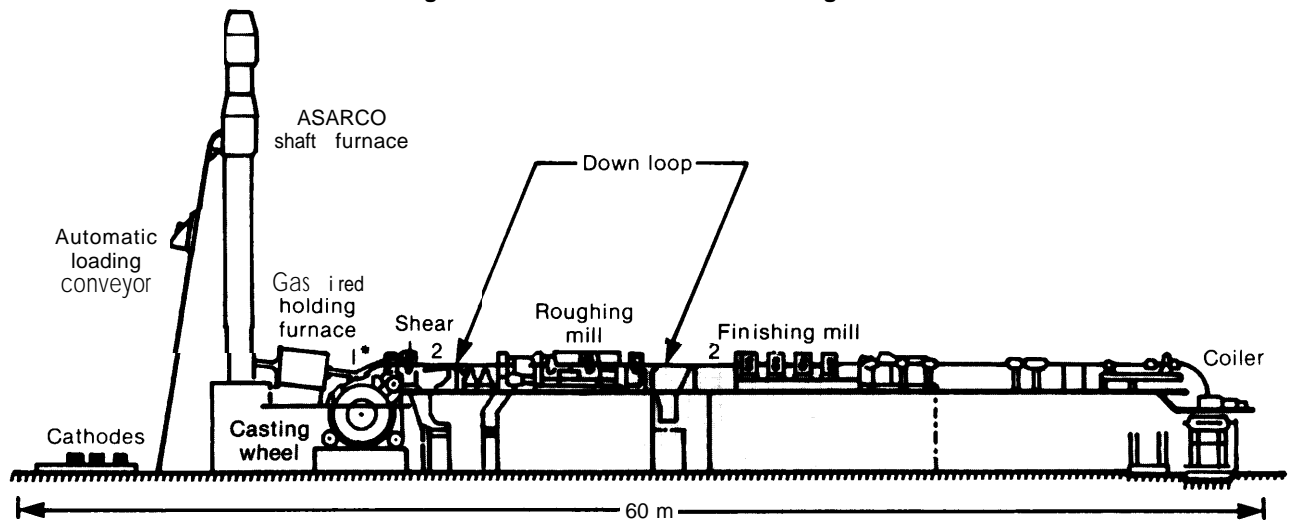
Figure 6-30.—Continuous Casting Wheel



SOURCE: A.K. Biswas and W.G. Davenport, *Extractive Metallurgy of Copper* (New York, NY: Pergamon Press, 1980).



Figure 6-31.—Continuous Rod Rolling Mill



\*NOTE The numbers refer to sensor positions for automatic control

SOURCE A K Biswas and W G Davenport, *Extractive Metallurgy of Copper* (New York, NY: Pergamon Press, 1980)

Chapter 7

# **Energy Use in the Copper Industry**

# CONTENTS

	<i>Page</i>
Mining . . . . .	152
Mineral Processing . . . . .	154
Pyrometallurgical Processes . . . . . \$ . . . . .	155
Air Quality Control . . . . .	156
Hydrometallurgical Processing . . . . .	157
Electrometallurgy. . . . .	157

## Figure

<i>Figure</i>	<i>Page</i>
7-1. Open-pit Mine Energy Use.....	152

## Tables

<i>Table</i>	<i>Page</i>
<b>7-1</b> Energy Requirements for Copper Production . . . . .	151
<b>7-2</b> Hypothetical Copper Operation for Analyzing Energy Use.....	<b>152</b>
7-3 Effect of Varying Cut-off Grade . . . . .	153
7-4 Energy Requirements for Pyrometallurgical Processes . . . . .	156
7-5 Reduction in Fuel Consumption Due to Oxygen Enrichment . . . . .	156
7-6 The Direct and Electrowinning Energy Demand of Selected Hydrometallurgical Processes for Treating Concentrates . . . . .	158

# Energy Use in the Copper Industry

All aspects of copper production require energy, whether in the form of electricity, explosives, or hydrocarbon fuels (diesel, gasoline, natural gas, fuel oil, coal, coke), or as the energy equivalent of materials consumed (e. g., chemicals and steel grinding media). In 1977, the primary copper industry purchased 121 **trillion** Btu of energy, or around 85 million Btu per short ton of cathode copper produced. <sup>1</sup>This compares to around 15 million Btu/ton for iron mining and steel production, 24 million Btu/ton for lead production, and 64 million Btu/ton for zinc,

**Mining uses about 20 percent of the total energy requirement; milling around 40 percent; and smelting, converting, and refining the remaining 40 percent.** Actual requirements vary widely depending on the mine characteristics and type of smelter, however. Table 7-1 shows one estimate of energy requirements in Btu equivalents for a hypothetical copper operation. It is interesting to note that pollution control equals a large percentage of the energy demand for smelting. In countries where pollution control is not required or is less stringent than in the United States, smelter energy demand could be as much as fifty percent lower. The significance of this difference would depend on the comparative energy costs, and the importance of energy for the total operating cost (see ch. 9).

A number of technological changes have reduced energy use in recent years. For example, automatic truck dispatching makes more efficient use of haulage and decreases diesel consumption. In-pit crushing and conveying can eliminate the need for truck haulage altogether, substituting electricity for diesel fuel. Computer control of other processes improves operating efficiency by maintaining operations as close to the ideal as possible. Changing from reverberatory to flash

<sup>1</sup>Michigan Technological University, *Effects of Increasing Costs on the Future Relation between Open Pit and Underground Mining*, report prepared for the U. S. Bureau Of Mines, December 1982, vol. 1.

**Table 7-1.—Energy Requirements for Copper Production**

Operation	10 <sup>6</sup> Btu/ton	Total	Percent of total
Open-pit mining: . . . . .		20.13	19-25
Drilling . . . . .	0.61		
Blasting . . . . .	3.90		
Loading . . . . .	1.85		
Hauling . . . . .	13.14		
Ancillary . . . . .	0.64		
Milling: . . . . .		42.73	40-52
Comminution . . . . .	0.16		
Beneficiation . . . . .	42.57		
Smelting: <sup>a</sup> . . . . .		6.2-22.7	8-21
Electric furnace . . . . .	22.68		
INCO flash . . . . .	6.27		
Outokumpu flash . . . . .	9.20		
Mitsubishi reactor . . . . .	12.21		
Noranda reactor . . . . .	10.41		
Converting: . . . . .		0.9-6.5	1-6
Electric furnace . . . . .	6.50		
INCO flash . . . . .	0.94		
Outokumpu flash . . . . .	2.13		
Mitsubishi reactor <sup>b</sup> . . . . .	3.02		
Noranda reactor <sup>b</sup> . . . . .	1.77		
Gas cleaning: . . . . .		6.3-8.2	8
Electric furnace . . . . .	7.73		
INCO flash . . . . .	7.76		
Outokumpu flash . . . . .	8.16		
Mitsubishi reactor . . . . .	6.25		
Noranda reactor . . . . .	7.36		
Electrorefining: . . . . .		5.6-6.3	6-7
Electric furnace . . . . .	5.61		
INCO flash . . . . .	6.29		
Outokumpu flash . . . . .	6.29		
Mitsubishi reactor . . . . .	6.29		
Noranda reactor . . . . .	6.29		
<b>Total . . . . .</b>		<b>81.9 -106.5</b>	

<sup>a</sup>Includes roasting and heat recovery, and all materials

<sup>b</sup>Includes slag cleaning.

SOURCE: Charles H. Pitt and Milton E. Wadsworth, *An Assessment of Energy Requirements in Proven and New Copper Processes* report prepared for the U.S. Department of Energy, contract no EM-78 -S-07.1 743, December 1980.

furnaces cuts total smelting and refining energy requirements by one-third. The use of leaching and solvent extraction eliminates smelting and converting altogether, Further conservation is possible, however.

This chapter reviews the energy requirements for the various stages of copper production, in-

**Table 7-2.—Hypothetical Copper Operation for Analyzing Energy Use**

Vertical depth below rim. . . . .	750'
Dynamic slope angle of sidewalls. . . . .	30°
Average slope of haul roads in pit . . . . .	6 %
Surface haul to dumps . . . . .	2,500 (6% grade)
Surface haul to primary crushers . . . . .	2,500 (level)
Overburden/ore body stripping ratio . . . . .	1.25
Mill head value of ore . . . . .	0.55 % Cu
Value of flotation concentrate . . . . .	25 % Cu
Value of flotation tails. . . . .	0.069 % Cu
Recovery factor ore to concentrate. . . . .	87.455 %
Recovery factor concentrate to cathode copper. . . . .	98.67%
Recovery factor ore to cathode . . . . .	86.29%
Primary cathode copper produced per year. . . . .	100,000 tons

SOURCE Charles H. Pitt and Milton E. Wadsworth, *An Assessment of Energy Requirements in Proven and New Copper Processes*, University of Utah, report prepared for the U.S. Department of Energy, contract no. EM-78-S-07-1743, December 1980, p. 25

cluding the type and amount of energy used, the variables that affect energy demand, and possible means of reducing demand. In each case, the estimates of energy demand are based on the hypothetical operation described in table 7-2.<sup>2</sup>

<sup>2</sup>Unless otherwise noted, the material in this chapter is drawn from Charles H. Pitt and Milton E. Wadsworth, *An Assessment of Energy Requirements in Proven and New Copper Processes*, report prepared for the U.S. Department of Energy, contract no. EM-78-S-07-1 743, December 1980.

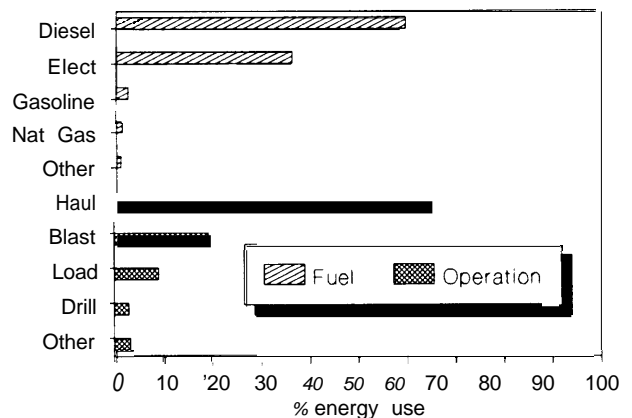
## MINING

The hypothetical open-pit mine described in table 7-2 uses an average of 20 million Btu of energy per ton of cathode copper produced, or about 21 percent of the energy consumed in producing copper (see figure 7-1 ). Approximately 59.7 percent of the energy is in the form of diesel or light fuel, **36.1** percent electricity, 2.4 percent gasoline, 1.0 percent natural gas, and 0.7 percent in some other form.<sup>3</sup>Hauling operations account for around 65 percent of the total energy consumed in open-pit mining, assuming conventional rock hauling by diesel-fueled dump trucks.<sup>4</sup> Blasting is the next largest use—about 19 percent—in the form of explosive energy. Electricity for shovel loaders and for drilling account for 9 percent and 3 percent, respectively. Finally, ancillary operations use around 3 percent of the total energy used in open-pit mining; these include auxiliary mobile equipment that consumes diesel fuel, gasoline, and lube oil; electrical pumping for pit dewatering; reclamation equipment such as scrapers, dozers, and graders, which use diesel and lube oil; and electrical sprinklers for revegetation.

<sup>3</sup>L. L. Gaines, *Energy and Material Flows in the Copper Industry*, Argonne National Laboratory, prepared for U.S. Department of Energy, December 1980.

<sup>4</sup>This estimate also includes the lube oil used by the trucks.

Figure 7-1. -Open-pit Mine Energy Use



Underground mines use electricity for generating compressed air, pumping, lighting, ventilation, and hauling miners and materials. They also use diesel fuel for surface hauling of ore to the mill. Approximately 155 pounds of explosives are used for every short ton of copper produced in underground mines.<sup>5</sup>

The average grade of the ore mined, the ratio of overlying dirt and rock (overburden) to the ore body (stripping ratio), and the depth of the pit

<sup>5</sup>Gaines, supra note 3.

below the surface rim all affect the amount and form of energy used in open-pit mining (and processing). There is a trade-off between energy conservation and resource recovery. The cut-off grade<sup>6</sup> used in mining determines: 1) how much ore and waste have to be transported, 2) how much ore is milled or waste is available for dump leaching operations, and 3) from the ore that is milled, how much copper is recovered and what volume of tailings is produced (see table 7-3).

The stripping ratio also affects where and in what form energy is consumed, because it de-

<sup>6</sup>As discussed in ch 5, the cut-off grade is the mineral value that must be present in the ore for it to be mined and processed economically. Material below that grade is left in situ or discarded as waste.

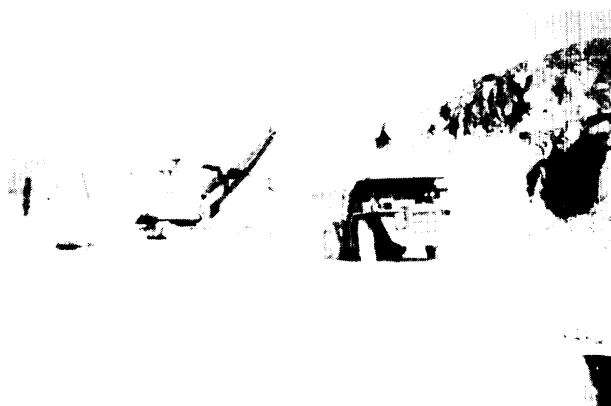


Photo credit: Jacques LeGross

Hauling accounts for around 65 percent of the total energy used in open pit mining.

termines how much material is handled as waste. In general, as the stripping ratio increases, the amount of mine energy per ton of cathode copper also increases. Similarly, as the pit depth below the surface rim increases, the vertical and horizontal distances that the waste rock and ore must be hauled also increases. This increase is reflected in greater energy use, primarily for hauling.

Much of the energy consumed in conventional hauling is used to move the heavy dump trucks, which are empty 50 percent of the time. Many mines today are replacing trucks with conveyor belt systems that run primarily on electricity. Truck haulage costs are around 4 times those of belt haulage costs.<sup>7</sup> One mine realized an energy savings of 30 percent with the partial use of conveyor systems.<sup>8</sup> Conveyers will not be feasible at all mines. **Because rock hauling accounts for such a large portion of the energy consumed in mining, however, it is one area where further research and development may result in large savings.**

optimization of the use of explosives for fragmentation versus increased crushing or grinding energy also can minimize energy use and lead to savings.<sup>9</sup>

<sup>7</sup>Assuming diesel fuel cost of 30 cents per liter and electricity at 5 cents per kWh.

<sup>8</sup>Robert J.M. Wyllie, "In-Pit Crushing Still Gaining Ground in Open Pit Mines," *Engineering and Mining Journal*, June 1987, pp. 76-80.

<sup>9</sup>See the discussion of comminution in ch. 6.

Table 7-3.—Effect of Varying Cut-off Grade<sup>a</sup>

Cut-off grade (% Cu)	Millhead grade (% Cu)	Tons milled (x 10 <sup>3</sup> )	Million Btu/ton cathode copper produced			
			Mining	Concentrating	Refining	Total
0.00	0.45	26.600	17.4	53.7	35.2	106.3
0.22	0.50	23.515	18.3	47.5	35.2	101.0
0.29	0.55	21.070	20.1	42.6	35.2	97.9
0.34	0.60	19.086	22.2	38.6	35.2	95.9
0.40	0.65	17,444	24.7	35.2	35.2	95.1
0.45	0.70	16.061	28.1	32.4	35.2	95.8

<sup>a</sup>It should be noted that the possible recovery of metal by means of dump leaching is not included in this table.

SOURCE: Charles H. Pitt and Milton E. Wadsworth. An *Assessment of Energy Requirements in Proven and New Copper Processes*, report prepared for the US Department of Energy, contract no. EM-78-S-07-1743. December 1980

## MINERAL PROCESSING

Grinding and concentration together consume about 45 percent of the energy used in the production of cathode copper. Assuming an ore grade of 0.55 percent and a recovery rate of **87.5** percent copper in the concentrate, concentrating 1 ton of copper ore requires over 200 billion Btu, or approximately 42 million Btu/ton of cathode copper.<sup>10</sup> Grinding accounts for roughly 60 percent of the total energy consumed in processing, and crushing 12 percent. Pumping new and recycled water, operating the flotation equipment, and regrinding and filtering account for the remainder.

<sup>10</sup>This includes the electrical energy to operate the equipment as well as the energy equivalent for the flotation chemicals, grinding media, and liners.

Crushing and grinding also consume a considerable amount of steel. The energy equivalent of these materials is sometimes included in energy analyses, and is about **6.4** million Btu. Similarly, flotation chemicals consumed have an energy equivalent of about 3.18 million Btu.

Two basic parameters affect the energy demand of processing mills: the amount of grinding needed to liberate the metal from the ore, and the hardness of the ore. The finer the grind, and the harder the ore, the higher the energy requirements. Hardness also dictates how much steel or other grinding media is consumed during ore processing.

**present crushing and grinding processes are extremely inefficient in their use of energy. Only**

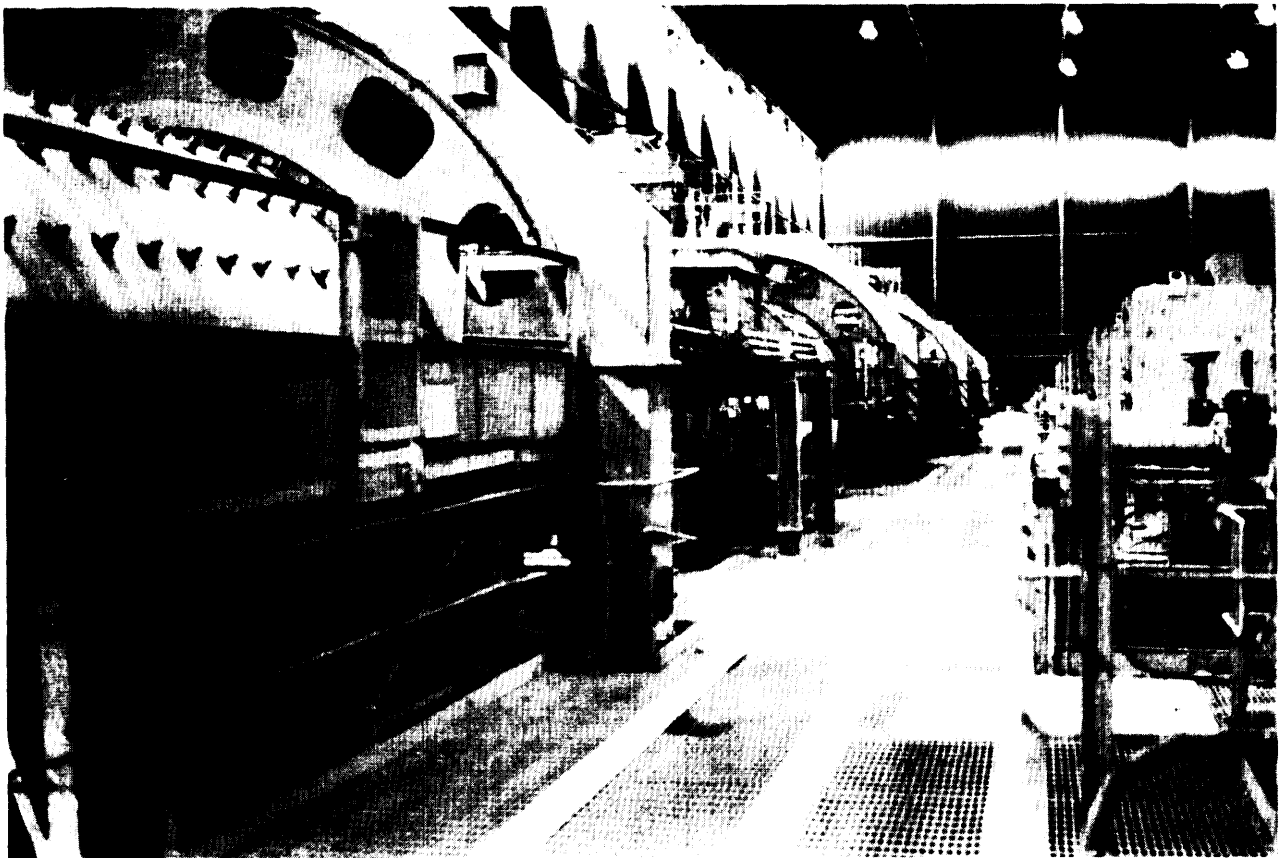


Photo credit: Jenifer Robison

Grinding accounts for approximately 60 percent of the energy used in milling.

1 to 2 percent of the energy input is used to create new surfaces on the mineral particles. Methods that could improve energy efficiency include installing automated controls (to optimize the throughput at a fixed energy input), using alternative types of grinding mills, and allocating energy among blasting, crushing, grinding and regrinding.

Controlling the size and content of ore entering the plant can improve energy efficiency 5 to 10 percent. Additional improvements could be realized with better classification devices to avoid regrinding fine material. Development of integrated control strategies for the entire comminution-beneficiation plant ultimately will lead to savings in both energy use and operating costs,

In some cases, steel grinding media can be replaced by pebbles or pieces of the ore itself (**autogenous grinding**). **Pebble** and autogenous grinding save materials costs, but are inefficient in direct energy use compared to conventional tumbling mills. The trade-off between materials conservation and energy efficiency is determined by the characteristics of the ore being processed and the difference between the prices of steel and energy. Therefore, the merits of autogenous or pebble grinding must be evaluated on a site-specific basis. Alternative grinding devices such as attrition mills which might have higher grinding efficiencies need additional research.

## PYROMETALLURGICAL PROCESSES<sup>11</sup>

Energy requirements vary widely for the different pyrometallurgical processes. Table 7-4 compares the energy requirements for seven smelter types, including the energy equivalents of the materials consumed by each process. Flash furnaces make the most efficient use of the thermal energy released during the oxidation of sulfides; they generate sufficient heat to provide a large proportion of the thermal energy for heating and melting the furnace charge.<sup>12</sup> Although electric furnaces use electrical energy efficiently because of the low heat loss through the effluent gas, they make limited use of the heat produced during oxidation of the sulfide minerals, and their energy costs are high because of the high price of electricity.

**Continuous smelting processes** theoretically would be more energy efficient than conventional smelting and converting because heat loss in transferring the matte to the converter would be eliminated. The potential for heat loss in fugitive emissions also would be reduced. As noted

in chapter 6, however, neither the Noranda nor the Mitsubishi process has yet proven truly continuous in practice. A genuine one-step process **could result in a savings of 10 to 20 percent of the energy used in smelting and converting.**

Although replacing an existing furnace is an expensive proposition, it is the surest way to cut energy consumption and control emissions. Most domestic smelters replaced their furnaces in the last 10 to 15 years, however. Thus, today's smelting energy conservation techniques rely on incremental improvements in fuel use, and on reducing heat loss.

Increasing the oxygen content of the air in the furnace is one way of improving fuel efficiency. Oxygen enrichment results in more complete oxidation, and thus a more efficient transfer of heat from the gas to the charge. This lowers the fuel requirements for reverberatory, Noranda, and flash furnace smelters (see table 7-5). Because of the higher thermal efficiency, less heat is lost through the stack gases. Oxygen enrichment also reduces the amount of nitrogen in the combustion air; nitrogen is capable of carrying off about 20 percent of the heat input to a furnace.<sup>13</sup>

<sup>11</sup>Pyrometallurgical recovery of copper is its extraction from ores and concentrates through processes employing chemical reactions at elevated temperatures (see ch. 6).

<sup>12</sup>Chemical reactions that produce more heat than they consume are termed "exothermic"; smelting processes that are exothermic and do not require additional energy once the furnace has been heated are called "autogenous."

<sup>13</sup>Gaines, supra note 3.



**Table 7.4.—Energy Requirements for Pyrometallurgical Processes** (million Btu/ton)

Process	Reverb- wet charge	Reverb- dry charge	Electric furnace	INCO flash	Outokumpu flash	Noranda reactor	Mitsubishi reactor
Materials handling . . . . .	0.73	0.73		0.73	0.57	0.79	0.66
Dry or roast. . . . .		0.66	2.67	1.86	1.23	0.80	1.29
<b>Smelting:</b>							
Fuel . . . . .	25.01	14.50			0.80	3.72	6.46
Electricity . . . . .	0.64	0.64	19.03	0.05		1.26	1.58
Surplus steam . . . . .	-10.00	-4.35			-3.43	-1.82	-8.00
<b>Converting:</b>							
Electricity . . . . .	1.63	1.26	2.92	0.94	0.64	0.37	1.42
Fuel . . . . .	0.54	0.32	3.58			0.09	0.25
Slag Cleaning . . . . .					1.49	1.31	1.35
<b>Gas cleaning:</b>							
Hot gas . . . . .	4.03	2.83	0.78	0.59	0.42	0.69	0.86
Cold gas . . . . .	0.25	0.40	2.21	0.31	0.21		0.32
Fugitive emissions . . . . .	3.57	3.57		3.57	3.57	3.57	0.89
Acid plant . . . . .	2.27	3.87	4.74	3.19	3.86	3.10	4.08
Water . . . . .	0.10	0.10		0.10	0.10		0.10
Anode furnace . . . . .	5.82	5.82	5.10	5.82	5.82	5.82	5.82
<b>Materials:</b>							
Miscellaneous . . . . .					0.04	0.65	0.63
Oxygen . . . . .				3.53	3.04	3.17	1.29
Electrodes . . . . .			0.86				0.16
Fluxes . . . . .	0.04	0.03	0.12	0.02	0.01	0.02	0.06
Water . . . . .	0.08	0.08		0.08	0.08		0.08
Anode furnace . . . . .	0.47	0.47	0.51	0.47	0.47	0.47	0.47
<b>Total . . . . .</b>	<b>35.18</b>	<b>30.93</b>	<b>42.52</b>	<b>21.26</b>	<b>18.92</b>	<b>24.01</b>	<b>19.77</b>

SOURCE: Charles H Pitt and Milton E. Wadsworth, *An Assessment of Energy Requirements in Proven and New Copper Processes*, report prepared for the US Department of Energy, contract no EM-78-S-07-1743, December 1980.

**Table 7-5.—Reduction in Fuel Consumption Due to Oxygen Enrichment**

Process	Oxygen enrichment	Reduction in fuel consumption
Reverberatory. . . . .	27%	20%
Outokumpu flash . . . . .	30-75%	autogenous <sup>a</sup>
INCO flash . . . . .	95.99 %	autogenous <sup>a</sup>
Noranda . . . . .	36%	34%
Mitsubishi . . . . .	58.3%	84%

<sup>a</sup>Autogenous means that no additional fuel is required to maintain the melt. The furnace uses the heat evolved from the exothermic oxidation of the metal sulfides to melt the charge. Therefore, fuel is only required initially to start the oxidation reactions

SOURCE Charles H. Pitt and Milton E. Wadsworth, *An Assessment of Energy Requirements in Proven and New Copper Processes*, report prepared for the U S Department of Energy, contract EM 78-S-07.1743, Dec. 31, 1980

Waste heat is recovered from both flash and reverberatory furnaces and used to preheat the combustion air and/or to generate electrical power (cogeneration) to drive the blowers in the acid plant and blow air in the converters. Waste heat also can be used to dry the furnace charge before smelting, because moisture can carry off the heat in the furnace and increase fuel requirements. Drying also helps to homogenize the

charge. Dryers usually are fueled with natural gas or oil and require from 1 to 3 million Btu/ton of cathode copper; using waste heat could save 0.7 million Btu/ton.

Roasting also dries the charge, and reduces the fuel requirements and effluent gas volume of the furnace. Like flash smelting, roasting can be an autogenous process that uses the exothermic heat generated by oxidation to continue the roast, so it does not require additional fuel.

## Air Quality Control

Sulfur dioxide emission controls account for 6 to 11 million Btu/ton of cathode copper (see table 7-4). The hot gases from the roaster, smelting furnace and converter are cleaned separately to recover copper metal entrained in the dust. The gas streams are then combined and cold gas cleaning is employed to remove dust that might foul the acid plant. Methods and energy requirements for controlling fugitive emissions vary based on the type of furnace and the building

enclosure, especially in the area of the converter aisle. The Mitsubishi reactor uses the least energy for controlling fugitive emissions because the molten matte transfer area is enclosed. Energy re-

quirements for acid plants are a function of the gas volume and sulfur dioxide concentration (see ch. 8).

## HYDROMETALLURGICAL PROCESSING<sup>14</sup>

Heap and vat leaching both require removal of the ore by conventional blasting and haulage (see ch. 6), and therefore would consume approximately the same amount of energy as mining, plus any electricity needed to pump the leach solution and the pregnant leachate. The main variables in the cost of pumping are the concentration of copper in the leachate (i.e., how much has to be pumped), and the vertical and horizontal distances between the leachate recovery area and the precipitation or solvent extraction facility.

Dump leaching exploits the waste remaining after conventional mining. Assuming that the costs are charged to the mining operation, dump leaching will have a relatively low energy cost. The energy is used primarily to drive the pumps, but can also include the energy equivalent of the chemical leaching solutions. Electricity for the pumps is estimated at around 13.5 million Btu/ton of cathode copper produced. In situ leaching energy consumption will vary depending on whether the ore needs to be drilled or otherwise fractured to provide enough permeability prior to pumping of the solution and leachate.

In dump leaching, energy savings can be achieved by optimizing the cut-off grade, taking into account the trade-off between conventional

processing and leaching. potential energy savings using this strategy are estimated at 20 to 25 million Btu/ton of cathode copper. Also, improving aeration, maintaining even fracture and porosity in the dump, and making more efficient use of the natural heat given off during oxidation will increase leachate-mineral contact and improve oxidation. These steps could save 10 to 20 million Btu/ton of cathode copper by making the most of each cycle of the leachate through the dump and thus reducing the amount of pumping necessary to recover the copper.

The pregnant leachate is processed through either precipitation or solvent extraction. Solvent extraction<sup>15</sup> is an extremely low energy process. Precipitation of copper on scrap iron consumes a small amount of electricity (50,000 Btu/ton of cement copper) for pumping the solution through the precipitation cell. The scrap iron's energy equivalent has been estimated to be 45 million Btu/ton of cathode copper. The primary difference in energy cost between the two processes is that cathode copper can be produced directly from the electrolyte from solvent extraction, but cement copper usually must be smelted, converted, and fire refined before it can be refined into cathodes.

<sup>14</sup>Hydrometallurgy is the recovery of copper from ore using water or water-based chemical solutions (see ch. 6).

<sup>15</sup>Solvent extraction uses a nonactive organic reagent that preferentially extracts copper ions from the leachate in order to increase the concentration of copper ions in the process solution.

## ELECTROMETALLURGY

Electricity is used to produce copper cathodes, either by transferring the copper from the electrolyte produced in solvent extraction onto cathode starter sheets (electrowinning), or by purifying copper anodes from smelting/converting by

electroplating (electrorefining). Electrowinning uses around 24 million Btu/ton of cathode copper—the electrical energy required to overcome voltage differences in the electrowinning cells, allowing copper to deposit on the starter sheets.

Electrorefining (including fire refining) requires approximately 6 million Btu/ton of cathode copper produced.

Other hydrometallurgical techniques are used to process concentrates (rather than leaching ore). These methods are not competitive with state-of-the-art smelting/refining on the basis of energy requirements, primarily due to the difference in energy use in electrowinning versus electrorefining. Table 7-6 shows the total direct and electrowinning energy demand of various hydrometallurgical methods for processing concentrates, and indicates to what extent electrowinning affects the total energy used.

Reducing the energy required for electrowinning requires decreasing the cell voltage while simultaneously maintaining a high current efficiency.<sup>16</sup> There is a critical current density at

which an acceptable cathode deposit can be expected. If this value is exceeded, the cathode becomes less dense, less pure, rough, and in general unacceptable as a commercial product. The critical current density can be increased by bubbling air through the cells (or other means of agitation).<sup>17</sup> Periodically reversing the current also can improve energy use (see ch. 6).

Electrowinning copper from cuprous (Cu<sup>+</sup>) as opposed to cupric (Cu<sup>2+</sup>) electrolytes is another means of reducing the energy demand. Cuprous electrolytes have shown an energy savings potential of 70 percent. They exhibit performance problems, however, primarily with regard to inadequate separation of impurities, and the cathodes are of lower quality than those from conventional electrorefining or electrowinning.

<sup>16</sup>W.C. Cooper, "Reduction in the Energy Requirements in Copper Electrowinning," *Metall.*, vol. 39, No. 11, November 1985, pp. 1049-1055.

<sup>17</sup>Ibid.

<sup>18</sup>Alan P. Brown et al., "The Electrorefining of Copper from a Cuprous Ion Complexing Electrolyte," *Journal of Metals*, July 1981, pp. 49-57, see also Cooper, supra note 16.

**Table 7-6.—The Direct and Electrowinning Energy Demand of Selected Hydrometallurgical Processes for Treating Concentrates**

Operation or process	Direct energy requirement (10 <sup>6</sup> Btu/ton cathode Cu)	Materials energy equivalent (10 <sup>6</sup> Btu/ton cathode Cu)	Electrowinning energy requirement (10 <sup>6</sup> Btu/ton cathode Cu)	Electrowinning energy as percent of the total energy demand
Arbiter ammonia leach <sup>b</sup> . . . . .	37.9	24.2	24.0	38.60/o
Roast leach electrowin <sup>bc</sup> . . . . .	28.8	1.6	22.4	73.6
Cymet ferric chloride leach <sup>b</sup> . . . . .	23.8	7.1	NA	
Sherritt-Cominco <sup>c</sup> . . . . .	38.7	9.4	24.0	49.8
Nitric-sulfuric acid leach <sup>b</sup> . . . . .	62.4	12.1	24.2	32.4
Electroslurry-Envirotech . . . . .	31.2	8.4	19.4	48.9
Roast/sulfite reduction . . . . .	17.8	5.9	NA	
Ferric sulfate acid leach <sup>b</sup> . . . . .	39.4	10.1	25.7	51.9

MM = million

NA indicates that electrowinning is not part of the process

<sup>a</sup>Processes that have been used Commercially.

<sup>b</sup>All hydrometallurgical processes

<sup>c</sup>Combination processes, using both pyrometallurgical and hydrometallurgical steps

SOURCE Charles H. Pitt and Milton E. Wadsworth. *An Assessment of Energy Requirements in Proven and New Copper Processes*, report prepared for the U S Department of Energy, contract no EM-78-S-07-1743, December 1980

Chapter 8

# **Environmental Aspects of Copper Production**

# CONTENTS

	<i>Page</i>
Air Quality . . . . .	162
Pollutants of Concern and Their Regulation . . . . .	162
Smelter Pollution Control . . . . .	163
Costs and Benefits of Pollution Control . . . . .	168
Water Quality and Waste Disposal . . . . .	170
Pollutants of Concern . . . . .	173
Waste Management Practices . . . . .	...174

## Boxes

<b>Box</b>	<i>Page</i>
8-A. Alternative Byproducts From the Control of Strong SO <sub>2</sub> Emissions . . . . .	165
8-B. Collecting Converter Gases . . . . .	168
8-C. The Resource Conservation and Recovery Act... . . . .	173
8-D. Factors Affecting the Potential for Contamination . . . . .	175

## Figures

<i>Figure</i>	<i>Page</i>
8-1. Environmental impacts of Copper Production . . . . .	161
8-2. Gas Cleaning in Copper Smelting . . . . .	165
8-3. Copper Converter Operation . . . . .	167
8-4. Air Curtain Control System . . . . .	169
8-5. Cost of SO <sub>2</sub> Removal With an Acid Plant . . . . .	171
8-6. Sulfur Dioxide Control . . . . .	172
8-7. Wasteland Management Practices . . . . .	176

## Tables

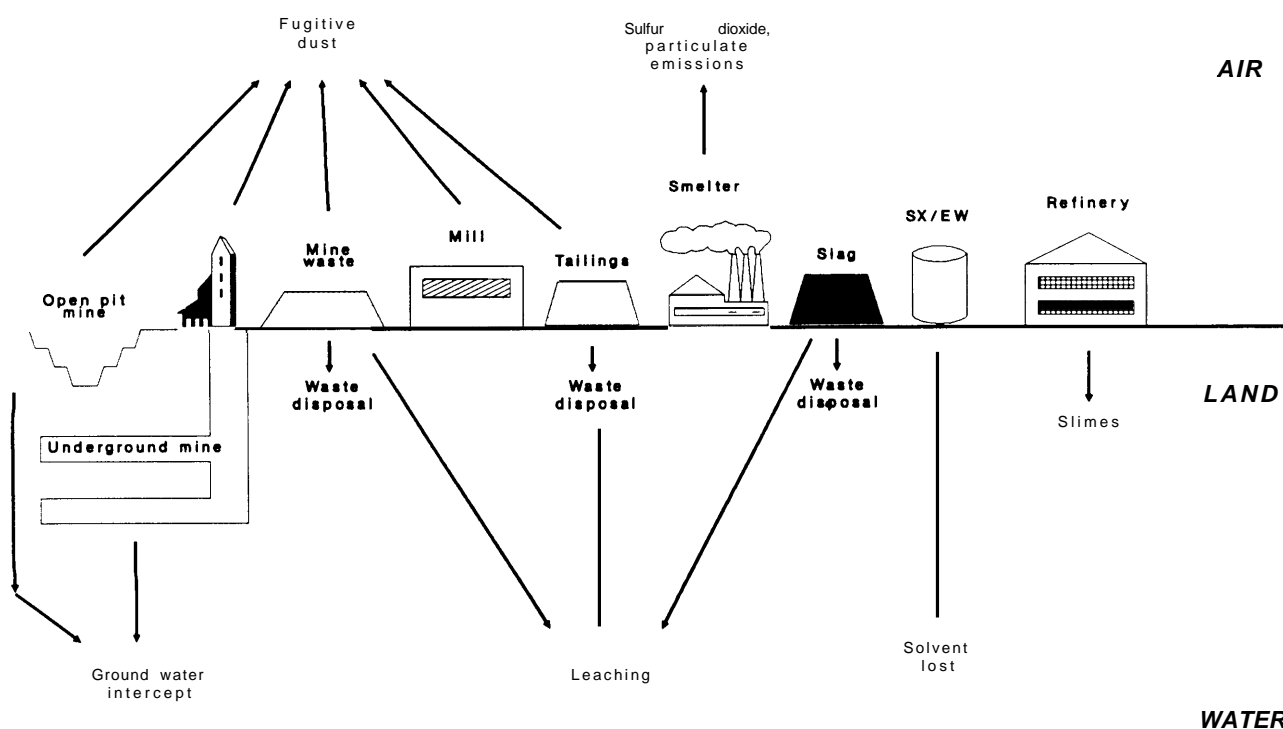
<i>Table</i>	<i>Page</i>
8-1. 1980 Sulfur Dioxide Emissions in the United States . . . . .	162
8-2. State and Federal Primary Ambient SO <sub>2</sub> Standards . . . . .	163
8-3. Smelting Technology and Associated Emissions . . . . .	164
8-4. Effluent Limitations on Discharges From Mines, Mills, and Leach Operations. . . . .	172

# Environmental Aspects of Copper Production

Copper production is not an environmentally benign activity. From mining and milling through hydro- and pyrometallurgical processing to refining, copper production can have significant adverse impacts on air quality, surface and ground-water quality, and the land (see figure 8-1). While these impacts can be severe when the materials handled include toxic or hazardous substances (e.g., ores with a relatively high concentration of arsenic), they also can be modest due to technological and other pollution controls, and because of mitigating features of the climate, geology, and ecology of most copper-producing areas in the United States.

As with all other industrial activities in the United States, **copper production is subject to extensive environmental regulation related to air and water quality, and materials handling and disposal practices. This regulation has had significant impacts on the mode and cost of domestic copper production.** For example, sulfur dioxide emission limitations resulted in the replacement of domestic reverberatory smelting furnaces with flash, electric, or continuous furnaces connected to plants that convert the sulfur dioxide to sulfuric acid. Operation of the acid plant increases smelter costs. For some domestic producers, the sulfuric acid is a salable by-

Figure 8-1.-Environmental Impacts of Copper Production



SOURCE: Office of Technology Assessment

product or usable at a nearby mine for leaching. It also can be a "red ink" item if there are no markets within an economical transportation distance.

**Operational changes resulting from environmental regulation have conferred significant (but less easily quantifiable) benefits for human health and the environment, but also have had a substantial adverse impact on the competitiveness of U.S. copper producers.** Any tightening

of the present air quality or waste management requirements would result in further closures of domestic copper operations.

This chapter reviews the environmental aspects of copper production. It presents a brief overview of the rationale for regulation, the technological controls, and the impact of those controls on domestic competitiveness. Further analysis of environmental regulation and its impact on the U.S. copper industry may be found in chapter 10.

## AIR QUALITY

### Pollutants of Concern and Their Regulation

Uncontrolled copper smelting processes emit large quantities of particulate matter, trace elements, and sulfur oxides, which can have adverse effects on human health. Sulfur dioxide (SO<sub>2</sub>), and the sulfates and sulfuric acid aerosols it forms in the atmosphere, can be lung irritants and aggravate asthma. Estimates of the magnitude of health risks and the influence of SO<sub>2</sub> and secondary pollutants from *all* emission sources range from 0 to **50,000** premature deaths per year in the United States and Canada.<sup>1</sup> Sulfur dioxide emissions from smelters also have been linked to visibility degradation and acid deposition.<sup>2</sup> Al-

<sup>1</sup>U.S. Congress, Office of Technology Assessment, *Acid Rain and Transported Air Pollutants: Implications for Public Policy*, OTA-O-204 (Washington, DC, U.S. Government Printing Office, June 1984), p. 13.

<sup>2</sup>Robert A. Eldred et al, "Sulfate levels in the Southwest during the 1980 Copper Strike," *Journal of Air Pollution Control*, vol. 33,

though fossil-fueled electric powerplants are the major source of SO<sub>2</sub> emissions in the United States, smelters contribute significantly to total emissions in the sparsely populated copper-producing areas of the West (see table 8-1).

Fugitive emissions from furnaces and converters can cause health problems in the work place and/or result in elevated levels of toxic pollutants such as lead and arsenic in the immediate vicinity of the smelter. Generally, employees are exposed to the highest concentrations of toxic elements because they work in enclosed areas. However,

No. 2, 1983; John Trijonis, "Visibility in the Southwest—An Exploration of the Historical Data Base," *Atmospheric Environment*, vol. 13, 1979, pp. 833-843, and sources cited therein; see also Robert Yuhnke and Michael Oppenheimer, *Safeguarding Acid Sensitive Waters in the Intermountain West*, Environmental Defense Fund, November 1984; see also "Acid Deposition in the Western United States," *Science*, July 4, 1986, pp. 10-14.

<sup>3</sup> Fugitive emissions are those that escape capture by normal air pollution control equipment.

**Table 8-1.—1980 Sulfur Dioxide Emissions in the United States (million metric tonnes)**

Source	National		East		West	
	Tons	Percent	Tons	Percent	Tons	Percent
Electric utilities . . . . .	15.8	65.6	14.6	73.5	1.2	28.6
Nonferrous smelters <sup>a</sup> . . . . .	1.4	5.8	0.2	0.8	1.2	29.0
Transportation . . . . .	0.8	3.3	0.5	2.5	0.3	7.3
Other . . . . .	6.1	25.3	4.6	23.2	1.5	35.1
Total <sup>c</sup> . . . . .	24.1	100.0	19.8	100.0	4.3	100.0

<sup>a</sup>Includes 28 nonferrous smelters, of which 27 were operating in 1980. Sixteen of the 28 are copper smelters—13 are in the

West. Eight of the copper smelters are still in operation

<sup>b</sup>Industrial, commercial, and residential sources

<sup>c</sup>Totals may not add due to rounding

SOURCE U S Congress, General Accounting Office, *Air Pollution Sulfur Dioxide Emissions from Nonferrous Smelters Have Been Reduced*, report to the Chairman, Subcommittee on Oversight and Investigations, Committee on Energy and Commerce, House of Representatives, GAO/RCED-86-91, April 1986.

contamination of the soil surrounding a smelter also is of concern. Fortunately, toxic metals are present only in very small concentrations in most domestic copper ores.<sup>4</sup> Only Asarco's El Paso smelter currently treats concentrates that are considered to have high levels of volatile impurities. The Anaconda-Butte and Asarco-Tacoma smelters used to treat such concentrates, but they closed in 1980 and 1985, respectively,

The Clean Air Act established National Ambient Air Quality Standards for six pollutants (see table 8-2). The Act requires that these standards be met throughout the United States, including the improvement of air quality in "dirty" areas and the prevention of significant deterioration of air quality in "clean" areas. These goals are achieved through emission limitations on various types of sources (including non-ferrous smelters) that require the use of technology-based controls. The Act also regulates emissions of hazardous pollutants. Substantial financial penalties are imposed for non-compliance.

<sup>4</sup>State of Arizona, Bureau of Air Quality Control, *Third Annual Report on Arizona Copper Smelter Air Pollution Control Technology*, April 1979.

<sup>a</sup>A "high level of volatile impurities" means a total smelter charge containing more than 0.2 percent arsenic by weight, 0.1 percent antimony, 4.5 percent lead, or 5.5 percent zinc, on a dry basis. Code of Federal Regulations, Title 40, Part 60.161. July 1, 1986.

**Table 8-2.—State and Federal Primary Ambient SO<sub>2</sub> Standards**

Federal . . . . .	0.03 ppm	annual average
	0.14 ppm <sup>a</sup>	24-hour average
	0.50 ppm <sup>a</sup>	3-hour average
Arizona . . . . .	0.03 ppm	annual average
	0.14 ppm	24-hour average
	0.50 ppm	3-hour average
Montana . . . . .	0.02 ppm	annual average
	0.10 ppm <sup>b</sup>	24-hour average
	0.05 ppm <sup>c</sup>	3-hour average
New Mexico . . . . .	0.02 ppm	annual average
	0.10 ppm	24-hour average
Utah . . . . .	0.03 ppm	annual average
	0.14 ppm	24-hour average
	0.50 ppm	3-hour average

KEY: 1 ppm SO<sub>2</sub> = 2620 µg/m<sup>3</sup>  
 ppm = parts per million  
 µg/m<sup>3</sup> = micrograms per cubic meter.

NOTE The 3-hour average is an annual geometric mean, to be used in assessment of plans to achieve the 24-hour standard

<sup>a</sup>No more than 1 violation/year

<sup>b</sup>No more than 2 violations/year

<sup>c</sup>No more than 19 violations/year

SOURCE Federal Code of Regulations, Title 40, Part 57102, July 7 1986

## Smelter Pollution Control

All stages of pyrometallurgical processing emit gases of varying content and volume (see table 8-3). Most technological methods of control involve collecting the gases and converting the SO<sub>2</sub> to some other product. The characteristics of the gases dictate the type of control technology, which in turn determines the kind of byproducts produced. For example, acid plants—the most widely used control technology—require a relatively high (at least 4 percent) SO<sub>2</sub> concentration in the off-gas for economical operation and compliance with pollution limitations. Roasters, flash furnaces, electric furnaces, continuous smelting furnaces, and converters all produce gases that can be treated in an acid plant. Weak gases, such as those from reverberatory furnaces and fugitive emissions, must be treated by alternate means. b

### Strong Sulfur Dioxide Emissions

Acid plants (figure 8-2) convert the sulfur dioxide in emissions to sulfuric acid (H<sub>2</sub>SO<sub>4</sub>). Other conversions, including to gypsum, elemental sulfur, and liquid SO<sub>2</sub> are technologically feasible, but usually not economically viable (see box 8-A).

In making sulfuric acid, the hot gases are first collected from the roasters, furnaces, and converters (see box 8-B). The gases are cooled, cleaned (through three series of dust collection systems) to recover copper from the dust and prevent fouling of the acid plant, and then treated with sulfuric acid to remove any water vapor. Catalysts convert the SO<sub>2</sub> gas to sulfur trioxide (SO<sub>3</sub>), which is absorbed in a circulating stream of 98.5 percent sulfuric acid and 1.5 percent water, and reacts with the water to form more concentrated acid.

There are two basic types of acid plants. In single contact/single absorption (SC/SA) plants, the gas goes through the system once; such plants average conversion (SO<sub>2</sub> to H<sub>2</sub>SO<sub>4</sub>) efficiencies of 96 to 98 percent. Double contact/double absorption (De/DA) plants maximize SO<sub>2</sub> capture

<sup>b</sup>In the conventional roasting-reverberatory smelting-converting sequence, only 50-70 percent of the SO<sub>2</sub> produced by the smelter can be captured with an acid plant.



Table 8-3.—Smelting Technology and Associated Emissions

Technology	Off gases (% SO <sub>2</sub> by volume)	Fugitive emissions
Multihearth roaster . . . . .	5-10	Leakage through the shell and open ports and during the filling of the transfer car (to transport matte to the furnace).
Fluid bed roaster . . . . .	10-12	
Reverberatory furnace . . . . .	0.5-2.5	Emissions escape through openings in the brickwork, during charging of calcine or green concentrate, during addition of converter slag, at slag and matte launders during tapping, at uptake and waste heat boilers.
Pierce-Smith converter:		
during blowing . . . . .	15-21	Emissions escape through the primary hooding system and are emitted directly from the mouth of the converter during charging and pouring.
during charging (change due to dilution with air) . . . . .	1-7	
Continuous smelting:		
Noranda process . . . . .	16-20	Noranda emissions from between the primary uptake hood and furnace mouth, from the mouth when in the rolled out position, around matte tapping, and at the port for feeding concentrates and fluxes.
Mitsubishi process . . . . .	11	
Electric furnace . . . . .	5 +	Fugitive emissions lower than most reverberatories; if not properly maintained, brickwork could be a source of emissions. Emissions may occur during slagging, matte tapping, converter slag return, around the electrodes, and the calcine handling.
Flash smelting:		
30% oxygen enriched . . . . .	10-20	Fugitive emissions at launders and ladles and from leakage through the furnace walls and roof.
tonnage oxygen . . . . .	70-80	
Hoboken Converter . . . . .	8-9	This converter has no primary hood, so any emissions from the mouth of the converter are fugitive emissions; properly designed, operated, and maintained, there are minimal fugitive emissions. Fugitive emissions occur during the hot metal matte charging or hot blister metal pouring.

SOURCE: Timothy W. Devitt, *Control of Copper Smelter Fugitive Emissions*, PEDCo-Environmental, Inc., May 1980, p. 14

by returning the gas stream to the converters through an intermediate absorption tower. These plants are capable of 99.7 to 99.8 percent conversion efficiencies.<sup>7</sup>

The design of an acid plant is unique to each smelter. The key variables affecting the efficiency and economics of acid production are the total gas volume; and the SO<sub>2</sub> concentration, water vapor concentration, and free oxygen content of the treated gases. The physical dimensions and energy requirements of the acid plant are largely determined by the maximum volume and minimum concentration of SO<sub>2</sub> gas.<sup>8</sup>

There are several reasons why acid plants are so widely used by the U.S. copper industry. The technology is well proven and is the least expen-

sive method of smelter SO<sub>2</sub> control. Sulfuric acid is used in solution mining, and also is the most common form in which other industries consume sulfur; thus it can be a salable byproduct rather than a waste. However, non-leaching markets for sulfuric acid generally are a long way from the smelters in the United States, and the resulting transportation costs can turn the byproduct credit into a deficit. Moreover, it often is cheaper for industrial consumers to buy sulfur and produce the sulfuric acid themselves than to purchase acid produced elsewhere.<sup>9</sup>

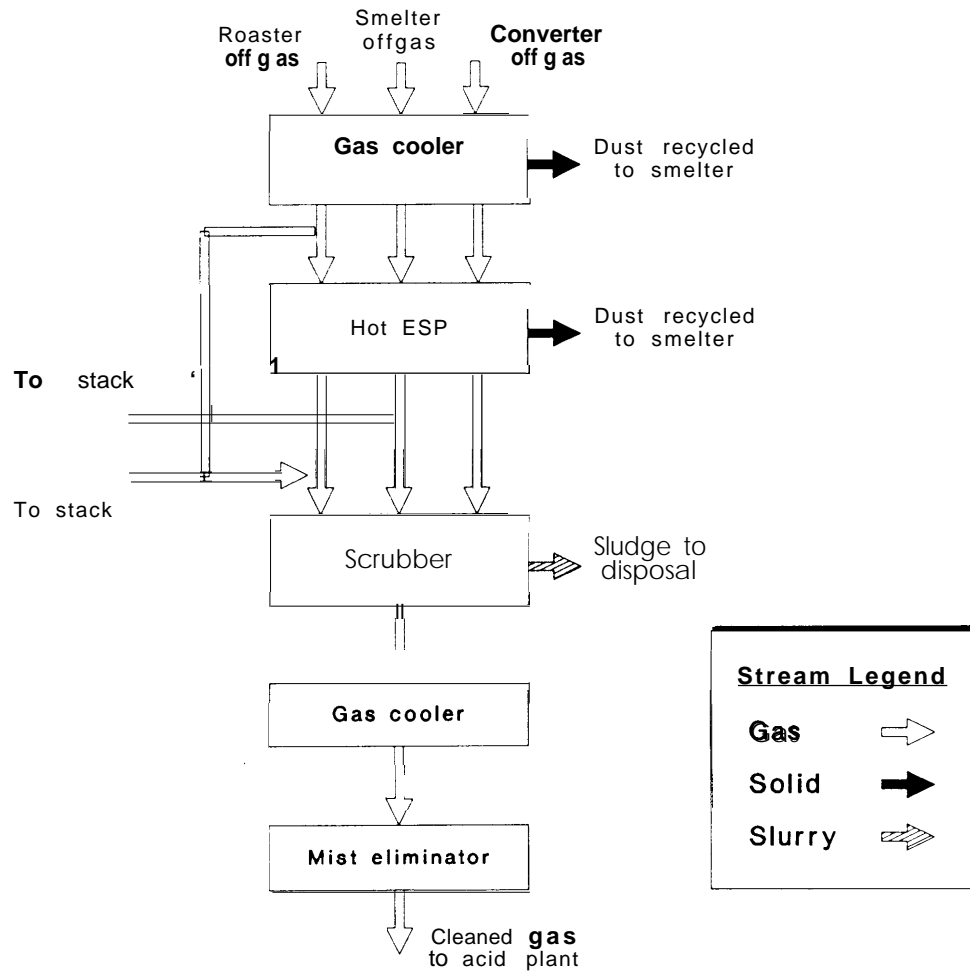
In some countries, such as Japan, a very high level of SO<sub>2</sub> control is achieved by copper smelters as part of a government policy to provide sulfuric acid for industrial development (see ch. 4). In less developed areas, such as the copper-producing countries of Africa and Latin America, there are

<sup>7</sup>Charles H. Pitt and Milton E. Wadsworth, *An Assessment of Energy Requirements in Proven and New Copper Processes*, report prepared for the U.S. Department of Energy, contract no. EM-78-S-07-1 743, December 1980.

<sup>8</sup>Ibid.

<sup>9</sup>Michael Rieber, *Smelter Emissions Controls, The Impact on Mining and the Market for Acid*, prepared for U.S. Department of the Interior, Bureau of Mines, March 1982.

Figure 8-2.-Gas Cleaning in Copper Smelting



SOURCE: Charles H. Pitt and Milton E. Wadsworth, *An Assessment of Energy Requirements in Proven and New Copper Processes*, report prepared for the U.S. Department of Energy, contract EM 78. S-07-1 743 Dec. 31, 1980

### Box 8-A.—Alternative Byproducts From the Control of Strong SO<sub>2</sub> Emissions

**Elemental Sulfur.** The reduction of sulfur dioxide to elemental sulfur is technically complex and requires an extremely high concentration of SO<sub>2</sub> in the off gases. Therefore, elemental sulfur production is feasible only with the INCO flash furnace, which uses tonnage oxygen (rather than oxygen-enriched air) and has emissions of up to **75** to **80** percent SO<sub>2</sub>. This conversion also requires large amounts of hydrocarbon fuel, such as coke, which reacts chemically with the SO<sub>2</sub> to form elemental sulfur. The fuel is relatively expensive and more than triples the energy requirement of the SO<sub>2</sub> control system.<sup>1</sup> However, elemental sulfur can be transported economically much greater distances than either sulfuric acid or liquid sulfur dioxide, and is more easily stored when demand is low.

**Liquid Sulfur Dioxide.** Liquid sulfur dioxide production also works best with a highly concentrated gas stream like that emitted by the INCO furnace. Liquid SO<sub>2</sub> has a very limited demand in the United States, but, owing to its relatively high price per unit weight, it can be shipped long distances. It is still extremely expensive to transport, however, because it requires special pressurized tank cars that usually return empty. The market is too small to justify cost saving measures such as unit trains or special ocean tankers.<sup>2</sup>

<sup>1</sup> D. A. Schultz, "Pollution Control and Energy Consumption at U.S. Copper Smelters," *Journal of Metals*, January 1978, p. 20.

<sup>2</sup> Michael Rieber, *Smelter Emissions Controls: The Impact on Mining and the Market for Acid* prepared for U.S. Department of the Interior, Bureau of Mines, March 1982.

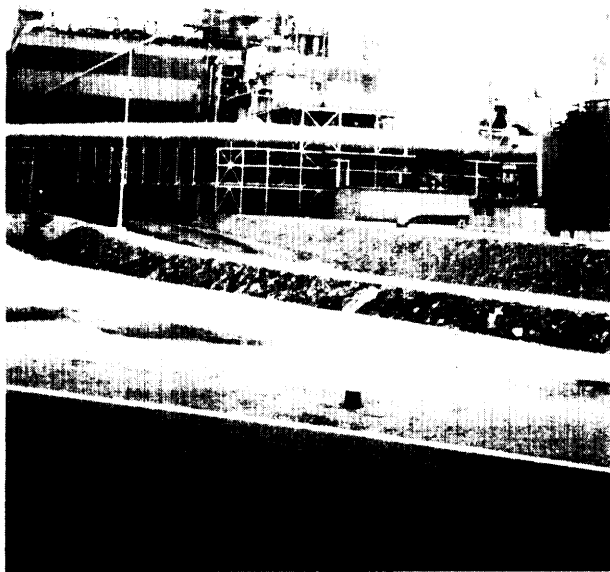


Photo credit: Robert Niblock

Acid plants entail extensive gas collection systems.

few industrial markets for acid, and  $\text{SO}_2$  control is minimal (see figure 8-6, below).

It is important to note that not all of the  $\text{SO}_2$  produced in a smelter is processed in the acid plant. Some of the sulfur dioxide gas is too weak to treat in the acid plant and some escapes as fugitive emissions. Gases from the acid plant itself contain unreacted sulfur dioxide and unabsorbed sulfur trioxide and usually are treated to remove acid mist before being vented to the atmosphere.

### Weak Sulfur Dioxide Emissions

Weak gas streams, with an  $\text{SO}_2$  concentration of less than 4 percent by volume, constitute a more difficult and costly problem than stronger streams. These include both smelter gases and fugitive emissions. For smelters, the three available control options are flue gas desulfurization,

modifying the furnace to produce stronger gas streams, and replacing the equipment with newer technology. All but two of the operating domestic smelters chose the third option.

In flue gas desulfurization (FGD), the  $\text{SO}_2$  is chemically removed through reactions with lime, magnesium oxide, ammonia, or dimethylaniline (DMA, an organic liquid). Regenerative FGD systems upgrade the sulfur dioxide content of the gases so that they may be further treated in an acid plant. Non regenerative systems result in a waste product (scrubber sludge). Although FGD is a well proven technology in fossil-fueled powerplants, and the Environmental Protection Agency (EPA) considers it adequately demonstrated in nonferrous smelters, very few smelters have actually installed scrubbers.<sup>10</sup> In early trials, smelters experienced frequent scaling and plugging problems with scrubbers. Phelps Dodge installed an experimental DMA system at their Ajo, Arizona smelter; it was operated intermittently and is no longer in use.<sup>11</sup> Currently, the White Pine, Michigan smelter is using gas scrubbers without an acid plant, and is in compliance with emission limitations.<sup>12</sup>

A broad range of reverberatory furnace modifications are available. The furnace can be sealed tightly to prevent infiltration of air and the subsequent dilution of the gases. oxygen-enriched smelting can increase the  $\text{SO}_2$  content of the off gases while it reduces the overall volume of gas. Weak or intermittent gas streams can be blended with stronger gas streams to produce a stream amenable to  $\text{SO}_2$  control. Supplemental sulfur can be burned in conjunction with a sulfuric acid plant to generate a supply of sulfur dioxide that can be used to beef up weaker gas streams.

Finally, reverberatory furnaces can be replaced with newer technology, resulting in the greatest improvements in sulfur capture. Although a complete smelter retrofit involves large capital costs

<sup>10</sup>A V Slack, "Application of Flue Gas Desulfurization in the Non-ferrous Metal Industry," *Sulfur Dioxide Control in Pyrometallurgy*, The Metallurgical Society of AIME, Chicago, Illinois, February 1981, p. 92.

<sup>11</sup>Pitt and Wadsworth, *supra* note 7.

<sup>12</sup>Janice L. W. Jolly and Daniel Edelstein, "Copper," preprint from 1986 *Bureau of Mines Minerals Yearbook* (Washington, DC: U.S. Department of the Interior, 1987).

(see ch. 9), the newer furnaces comply more easily with air quality standards and are more efficient. Another alternative involves replacing or augmenting smelting with hydrometallurgical processes. Leaching and solvent extraction do not produce sulfur dioxide gas, but they can fall under water quality and waste disposal regulation. Moreover, only oxide ores and oxidized waste material currently can be leached economically.

The Pierce-Smith converter is the major source of fugitive emissions in a smelter building. Fugitives are emitted directly when the converter is rolled for the addition of matte (figure 8-3). They escape the primary hood (box 8-B) when it is moved to provide clearance for the overhead crane and matte ladle. Significant amounts of gases also escape from the hood during air injection (blowing). Moreover, the fan in the hood shuts down during charging, but, before the converter has completely rolled back to the vertical position and the hood and fan are fully operational, blowing resumes, allowing fugitives to escape.<sup>13</sup>

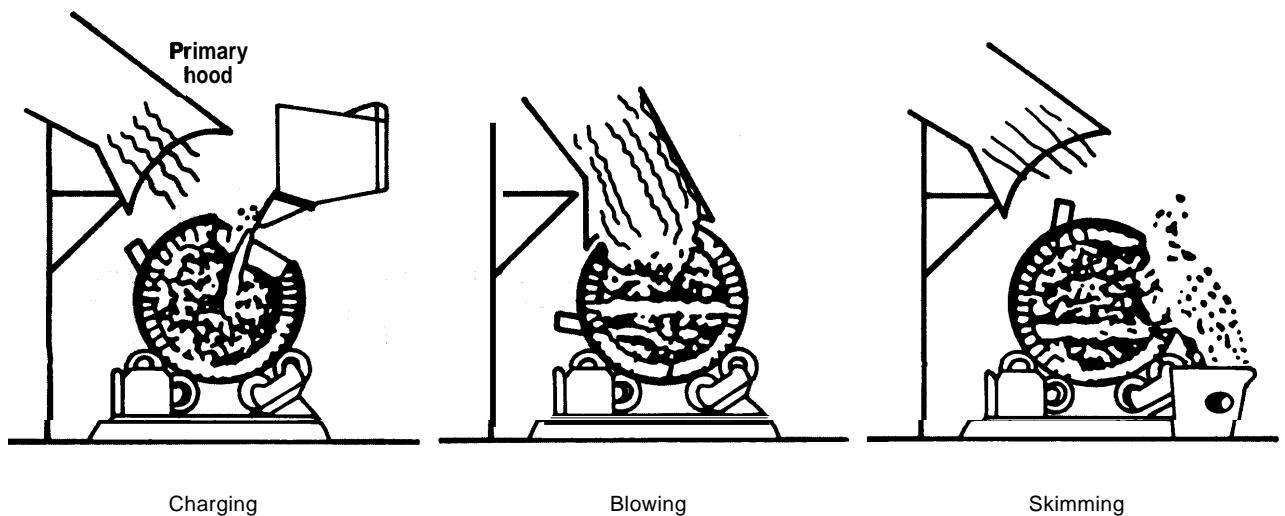
<sup>13</sup>Timothy W. Devitt, *Control of Copper Smelter Fugitive Emissions*, PEDCo-Environmental, Inc., May 1980, p. 14.



Photo credit: Manley Prim Photography, Tucson, AZ

Skimming from a converter.

Figure 8-3.—Copper Converter Operation



SOURCE: John O. Burckle et al., *Evaluation of an Air Curtain Hooding System for a Primary Copper Converter*, Vol. 1, Prepared for U S Environmental Protection Agency, Industrial Environmental Research Laboratory, by PEDCo Environmental, Inc., February 1984

### Box 8-B.—Collecting Converter Gases

Converter gas streams are more difficult to collect than those from roasters and smelters. A hood is lowered to the converter mouth to capture the gases and particulate matter that are emitted while air is being blown into the matte. The primary hooding system on most converters consists of a fixed hood with a sliding gate located above and slightly away from the converter (see figure 8-3). During blowing, the gate is lowered to the converter mouth to help guide the emissions and reduce the intake of cool ambient air.

Primary hoods are not 100 percent efficient because the gate does not form a perfectly tight seal with the converter mouth. At plants where the gates were retrofitted rather than designed and installed as part of the original smelter, the gate often does not completely cover the converter mouth. Contact with the crane and ladles also can damage the hooding system, and preventive maintenance is required to repair leaks due to normal wear and tear.

A secondary hood that slips over the primary hood affords some additional emissions capture during the critical times of charging and skimming. Double hood systems have exhibited operational problems, however. They can become warped to the point that they no longer fit over the primary hood, and at times they do not supply enough draft or are too far from the mouth of the converter to be effective. }

<sup>1</sup>Carl H. Billings, *Second Annual Report on Arizona Copper Smelter Air Pollution Control Technology*, State of Arizona, Bureau of Air Quality Control, April 1978, p. 40

Methods of capturing fugitive emissions from converters include secondary hoods, air curtains, ventilation systems, and alternative converter technologies. Air curtains use a row of nozzles to create a stream of air that captures around 90 percent of the gaseous emissions and particulate over the converter (see figure 8-4).<sup>14</sup> As with primary hoods, however, contact with cranes and

<sup>14</sup>John O. Burckle, et al., *Evacuation of an Air Curtain Hooding System for a Primary Copper Converter, Volume I*, Prepared for U.S. Environmental Protection Agency, Industrial Environmental Research Laboratory, by PEDCo Environmental Inc., February 1984, p. 4.

ladles can damage or misalign air curtains. This sort of technology could be effective at fugitive emissions control if design changes could make it more adaptable to the smelter environment.

Another option for fugitive emissions control is a total building ventilation and collection system. Such a system did prevent high ambient air readings at monitoring stations around one smelter in which it was tried, but created dead spots inside the building where there were increased concentrations of SO<sub>2</sub> and elevated temperatures, largely due to inadequate fan capacity. Total ventilation may also create heating problems during cold spells as most of the heat is evacuated with the emissions.<sup>15</sup>

Alternative converter technologies include continuous reactors and the Hoboken converter. Continuous reactors theoretically combine roasting, smelting, and converting in one operation. In the Mitsubishi continuous reactor, the converter portion is enclosed and the potential for fugitives should be reduced substantially. The Noranda reactor both has a hood and typically is used in conjunction with a Pierce-Smith converter (see ch. 6).

Inspiration Consolidated Copper Company (ICCC) experimented with an induced draft Hoboken Converter, which was supposed to control emissions by maintaining a negative draft at the mouth at all times. Concentrations of 8 to 9 percent SO<sub>2</sub> were achieved in early tests—sufficient for treatment in an acid plant. Subsequently, however, ICCC experienced operational problems, fugitive emissions became progressively worse, and they replaced the converter.<sup>16</sup>

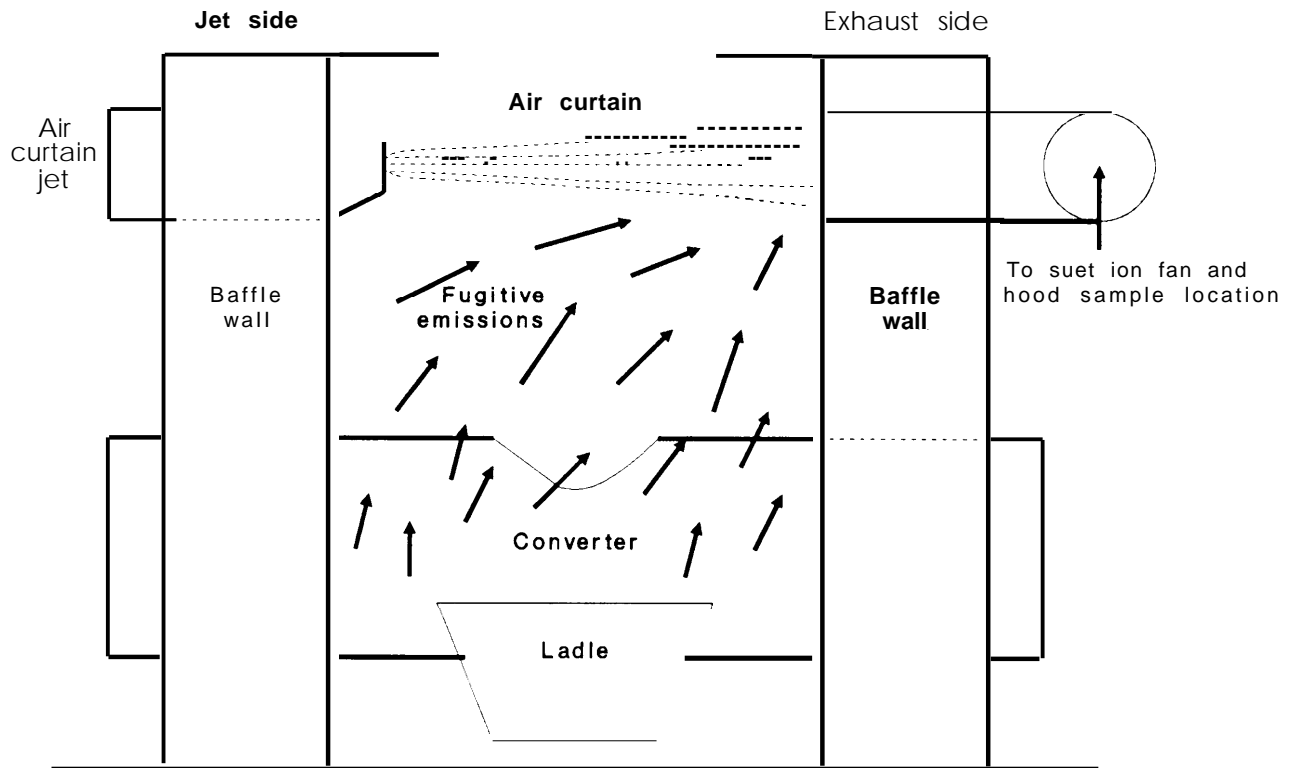
## Costs and Benefits of Pollution Control

**Control strategies have resulted in marked improvements in long term SO<sub>2</sub> levels in the past 15 years, with substantial benefits for public health and the environment.** According to EPA statistics, copper smelters reduced their total sul-

<sup>15</sup>Carl H. Billings, *Third Annual Report on Arizona Copper Smelter Air Pollution Control Technology*, Arizona Bureau of Air Quality Control, April 1979, p. 42.

<sup>16</sup>*Ibid.*

Figure 8-4.-Air Curtain Control System



SOURCE John O Burckle et al., Evaluation of an Air Curtain Flooding System for a Primary Copper Converter, vol. 1, report prepared for U.S. Environmental Protection Agency, Industrial Environmental Research Laboratory, by PEDCO Environmental, Inc., February 1984.

fur dioxide emissions from 3.5 million tons in 1970 to **970,000** tons in 1983—a 72 percent reduction. The percent of input sulfur captured at domestic smelters is currently 90 percent.<sup>17</sup>

**These gains were not easy.** By the very nature of their operation, smelter and converter emissions are difficult and expensive—to capture and control. Before technological means of control became mandatory, smelters used supplemental and intermittent SO<sub>2</sub> controls.<sup>18</sup> While these

<sup>17</sup>Duane Chapman, "The Economic Significance of Pollution Control and Worker Safety Costs For World Copper Trade," Cornell Agricultural Economics Staff Paper, Cornell University, Ithaca, New York, 1987.

<sup>18</sup>Supplemental control systems include the use of very tall stacks to disperse pollutants, thus diluting their ambient concentration. Intermittent control consists of monitoring the ambient weather conditions to identify when wind patterns and temperature inversions could trap the pollutants near the source instead of dispersing the plume. Under these conditions, production is cut back to the point necessary to reduce pollutant emissions to an acceptable ambient concentration,

methods resulted in lower overall SO<sub>2</sub> emissions, they also reduced production.<sup>19</sup> When smelters had to install technological controls, many closed because the capital cost of retrofitting the smelter was too high. The General Accounting Office estimates that between 1970 and 1984, 44 percent of the reduced emissions from non-ferrous smelters (including lead and zinc operations) were due to improvements in control techniques, while 56 percent were due to decreased production.<sup>20</sup> (Smelters that closed during 1984 and 1985 had been responsible for over half of NAAQS violations.)

**Although the need to replace reverberatory with other furnaces plus pollution control devices**

<sup>19</sup>Rieber, supra note 9.

<sup>20</sup>U.S. Congress, General Accounting Office, *Air Pollution, Sulphur Dioxide Emissions From Nonferrous Smelters Have Been Reduced*, April 1986, p.4.

**brought social benefits and increased furnace efficiency, it also cost the domestic industry an enormous amount of money and contributed to the closure of significant domestic capacity.**

The primary copper industry had capital investments totalling \$2.088 billion for air pollution control between 1970 and 1981, with average annual costs of \$3.074 billion.<sup>21</sup> Furthermore, adding an acid plant to the production line increases operating costs without necessarily providing a byproduct credit. Present levels of control entail capital and operating costs of between 10 and 15 cents per pound of copper.<sup>22</sup>

The capital cost of sulfur removal, which includes gas handling of a 4 percent sulfur dioxide gas stream and the sulfuric acid plant at a 50,000 tonne per year copper facility, has been estimated at \$560 per annual tonne of copper produced.<sup>23</sup> This is approximately 20 percent of the total capital costs of the facility. Both the capital investment and the operating cost for SO<sub>2</sub> removal decrease with increasing concentration of SO<sub>2</sub> in

<sup>21</sup> Lawrence J. McDonnell, "Government Mandated Costs: The Regulatory Burden of Environmental, Health, and Safety Standards of U.S. Metals Production," paper prepared for the conference Public Policy and the Competitiveness of the U.S. and Canadian Metals Production, Golden, CO, January 1987.

<sup>22</sup> Everest Consulting, *Air Pollution Requirements for Copper Smelters in the United States Compared to Chile, Peru, Mexico, Zaire and Zambia*, 1985.

<sup>23</sup> Jagdish C. Agarwal and Michael J. Loreth, "Preliminary Economic Analysis of SO<sub>2</sub> Abatement Technologies," *Sulfur Dioxide Control in Pyrometallurgy*, The Metallurgical Society of AIME, February 1981.

the gas stream because of lower costs associated with handling a smaller gas volume (see figure 8-5). Fugitive emissions are the most difficult and expensive to control because they are dilute, have a large volume, and are not easy to capture.

In comparison, copper smelters in Chile, Canada, Peru, Mexico, Zaire, Zambia and Japan—our major foreign competitors—are not faced with similar environmental regulations. In all but Japan, if smelter emissions are controlled at all, it is only to the extent that sulfuric acid is needed at an associated leaching project. Copper smelters in these countries capture between 0 and 35 percent of the input sulfur; on average only about one-fifth of the present level of U.S. control (see figure 8-6). Japanese smelters achieve 95 percent control as part of government policy to subsidize sulfuric acid production. Information regarding the costs of acid production in these countries is not available.<sup>24</sup> However, it is clear that domestic regulation puts U.S. producers at a competitive disadvantage.

Future capital investments in Chile, Peru, Mexico, Zaire, Zambia may be funded in part by the World Bank (see ch. 3). The World Bank requires environmental controls as a condition for financing, but they are less stringent than Clean Air Act standards, and compliance is not monitored.<sup>25</sup>

<sup>24</sup> MacDonnell, *supra* note 21.

<sup>25</sup> Everest Consulting, *supra* note 22.

## WATER QUALITY AND WASTE DISPOSAL

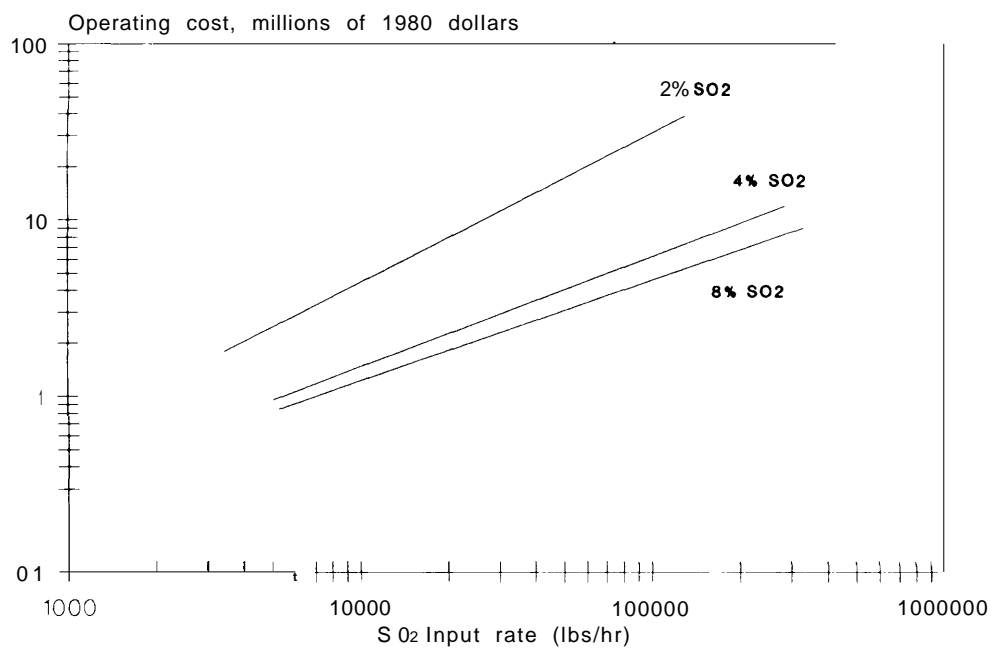
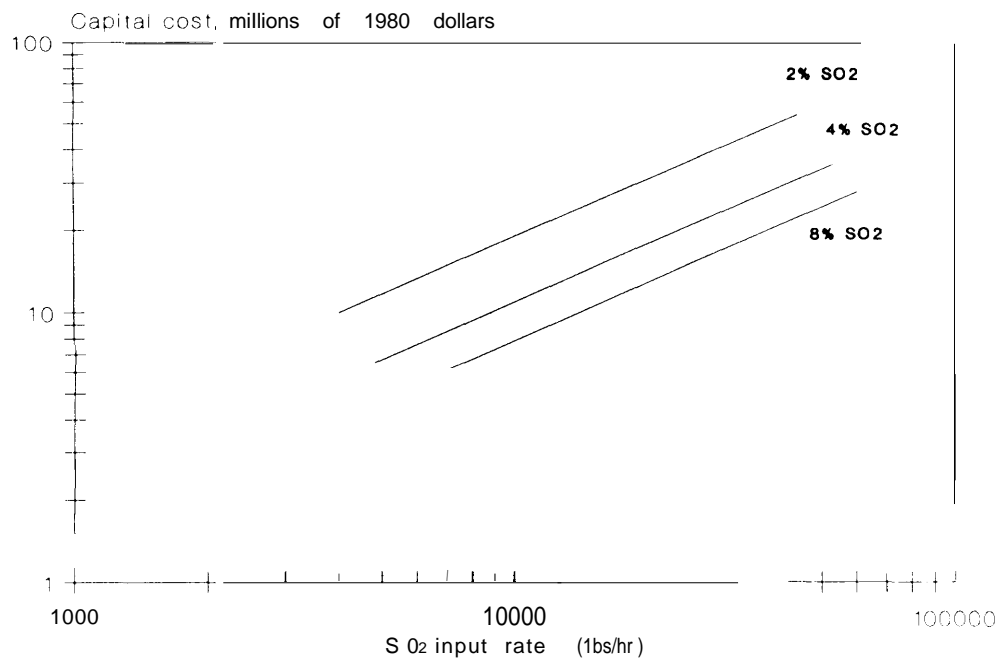
All aspects of copper production—from mining and leaching to milling, smelting, refining and electrowinning—have potential impacts on surface and groundwater quality (see figure 8-1).<sup>26</sup> Adverse water quality impacts are caused primarily by land disposal practices that fail to contain wastes, by run-on and run-off controls that are inadequate to prevent surface water from flow-

<sup>26</sup> surface waters include the various forms of water occurring on the surface of the earth, such as streams, rivers, ponds, lakes, etc. Groundwater is water that flows or seeps downward, saturating soil or rock and supplying springs or wells. The upper level of this saturated zone is called the water table. Aquifers are underground water sources large enough to be used for public water supplies.

ing through impoundments, or by groundwater infiltrating surface impoundments.<sup>27</sup> In addition, the large-scale land disturbances associated with open-pit mining may disrupt the natural flow of surface and groundwaters, and may lower the water table in the mine area. Lowering the water table may cause water shortages, land subsidence, and fracturing; the latter facilitates the transport of contaminants into and through an aquifer.

<sup>27</sup> SCS Engineers, *Summary of Damage Sites from the Disposal of Mining Wastes*, prepared for the U.S. Environmental Protection Agency, January 1984.

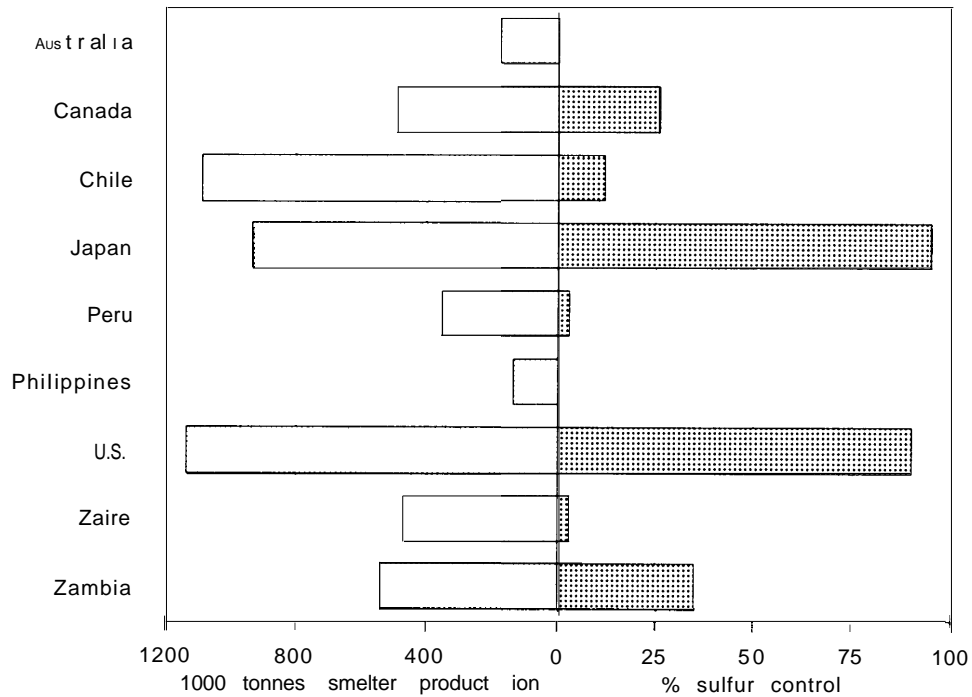
**Figure 8-5.-Cost of SO<sub>2</sub> Removal with an Acid Plant**



SOURCE: Jagdish C. Agarwal and Michael J. Loreth, "Preliminary Economic Analysis of SO<sub>2</sub> Abatement Technologies," *Sulfur Dioxide Control in Pyrometallurgy*, The Metallurgical Society of AIME, February 1981



**Figure 8-6.-Sulfur Dioxide Control**



SOURCE Duane Chapman, "The Economic Significance of Pollution Control and Worker Safety Costs for World Copper Trade," Cornell Agricultural Economics Staff Paper, Cornell University, Ithaca, New York, 1987.

The EPA administers four major legislative programs that could affect water quality control and waste disposal practices at domestic copper mining operations: 1) the Clean Water Act, which imposes effluent limitations on point sources (see table 8-4) and requires permits for the discharge of any effluent under the National Pollution Discharge Elimination System (NPDES); 2) the Resource Conservation and Recovery Act (RCRA), which regulates the generation, transport, and disposal of hazardous and solid wastes (see box 8-C); 3) Superfund, which assigns priorities for, and oversees the cleanup of, polluted sites; and 4) the Safe Drinking Water Act, which is designed to protect the quality of public drinking water supplies. In addition, new or substantially modified copper operations are subject to the National Environmental Policy Act of 1969 (N EPA), which requires Federal agencies to prepare an environmental impact statement (EIS) for any major Federal action (e.g., issuing a permit) that will signifi-

**Table 8-4.—Effluent Limitations on Discharges from Mines, Mills, and Leach Operations<sup>a</sup>**

Effluent characteristic	Effluent limitations (mg/l)	
	Maximum for any one day	Average of daily values for 30 consecutive days
TSS .....	30.00	20.00
Cu .....	0.30	0.15
Zn .....	1.50	0.75
Pb .....	0.60	0.30
Hg .....	0.002	0.001
pH .....	6.0-9.0	6.0-9.0
Cd .....	0.10	0.05

<sup>a</sup>Leaching Operations are expected to achieve zero discharge unless the annual precipitation exceeds the annual evaporation, in which case a volume of water equal to the amount exceeding annual evaporation may be discharged subject to NPDES limitations

SOURCE: *Ore Mining and Dressing Point Source Category Water Pollution Effluent Guidelines*, 40 CFR Ch.1 (7-1-85 edition)

icantly affect the environment. Tailings dams also are subject to Federal design standards to ensure public safety.

**Although water quality control and waste management have not yet had the same finan-**

### Box 8-C.—The Resource Conservation and Recovery Act

Future regulation of mine wastes under the Resource Conservation and Recovery Act (RCRA) is of major concern to the domestic copper industry. Subtitle C of RCRA governs hazardous wastes, while subtitle D provides guidelines for non-hazardous solid and liquid wastes. In 1986, EPA decided that solid wastes from the mining and beneficiation of copper ores should not be regulated under Subtitle C of RCRA as hazardous, even though copper dump leach liquor, copper dump leach wastes, and tailings may exhibit hazardous characteristics of corrosiveness or Extraction Procedure (EP) toxicity.<sup>1</sup> The rationale for this decision was that the large volumes of mine waste would be very difficult to regulate under rules designed to manage much smaller amounts of industrial and municipal waste. Also, EPA reasoned that Subtitle C does not allow considerations of environmental necessity, technological feasibility, and economic practicality, which are important given the magnitude of mine waste.<sup>2</sup>

The cost of mine waste management under Subtitle C of RCRA would result in further closures of domestic mines and mills. EPA believes that concerns about actual and potential releases of hazardous contaminants from mine wastes can be addressed adequately by designing a regulatory program specific to such wastes under the more flexible Subtitle D solid waste management authority. Subtitle D gives EPA the authority to set waste management standards intended to protect surface and groundwater quality and ambient air quality. At the same time, it allows consideration of the varying geologic, hydrologic, climatic, population and other circumstances under which different waste management practices assure reasonable environmental protection.<sup>3</sup>

Critics of this approach argue that Subtitle D regulations do not fully address mine waste concerns, especially for hazardous wastes. In addition, based on information supplied largely by the mining industry, EPA is uncertain whether current waste management practices can prevent damage from seepage or sudden leaks.<sup>4</sup>

<sup>1</sup> The EP toxicity tests are a analytical technique used by EPA to predict the leaching potential of wastes.

<sup>2</sup> U.S. Environmental Protection Agency (EPA), *Wastes from the Extraction and Beneficiation of Metallic Ores, Phosphate Rock, Asbestos, Overburden from Uranium Mining and Oil Shale*, Report to Congress, December 1985, p. ES-13.

<sup>3</sup> Non-Coal Mining Wastes To Be Regulated Under RCRA, But Not All Hazardous, EPA Says, *Environment Reporter*, July 4, 1986, pp 355-356.

<sup>4</sup> Regulatory Determination for Wastes from the Extraction and Beneficiation of Ores and Minerals, *Federal Register*, July 3, 1986.

**cial or capacity impact on the domestic copper industry as air pollution control, their costs are not insignificant.** The U.S. nonferrous ore mining and dressing sector had a total capital investment of \$667 million in water pollution control between 1970 and 1981, with average annual costs of \$708 million.<sup>28</sup> Copper operations handle much larger amounts of material than other metal mining industries and generate considerably more solid waste, and a large share of this cost can be assigned to the domestic copper industry—perhaps as much as half. Data on foreign water pollution control practices were not available.

### Pollutants of Concern

The mining and beneficiation of copper ore produces enormous volumes of liquid and solid

<sup>28</sup> MacDonnell, *supra* note 21.

waste. The EPA estimates that, between 1910 and 1981, all types of metallic ore mining and beneficiation in the United States generated a cumulative total amount of waste of more than 40 billion tonnes. Copper production accounts for roughly half of this total. In 1980, when U.S. copper mine production was 1 million tonnes, the domestic industry generated an estimated 282 million tonnes of mine waste, 241 million tonnes of tailings, and 200 million tonnes dump leach wastes.<sup>29</sup>

Most of the copper mined in the United States comes from sulfide ores such as chalcopyrite and bornite—mineral compounds characterized by the linkage of sulfur with the metal(s) (see ch. 5).

<sup>29</sup> U. S. Environmental Protection Agency (EPA), *Wastes from the Extraction and Beneficiation of Metallic Ores, Phosphate Rock, Asbestos, Overburden from Uranium Mining, and Oil Shale*, Report to Congress, December 1985, p. ES-13.

Mining exposes the sulfides to water and air, causing a reaction that forms sulfuric acid and iron. The acidic effluents can dissolve and transport heavy and toxic metals from the solid waste or surrounding ground. Arsenic, lead, and cadmium are the metals of concern most commonly associated with copper ores. These toxic metals can accumulate in the environment and concentrate in the food chain, reaching levels that are toxic to both human and aquatic life. Removal and fracturing of rock and soil during mining also speeds up normal weathering processes and increases the load of sediments and fine solids transported by wind and water.

The EPA conducted a study to determine whether mine waste facilities leak and, if they do, whether they release contaminants of concern in significant quantities. Surface and groundwaters were monitored at eight active metal mine sites. Results indicated that constituents from impoundments do enter groundwater at most sites, but significant increases in concentrations of hazardous constituents were rarely demonstrated. so

On the other hand, court cases show that runoff and seepage have caused surface and groundwater contamination at active, inactive, and abandoned mine sites. Much of the damage was caused by outmoded disposal practices, but the relatively even distribution among the three types of facility status indicates that the problem is not associated solely with abandoned or inactive mine sites.<sup>31</sup> Some sites may have been active for a long time, however, and while even there the problematic disposal practices are no longer in use, their effects may continue.

The potential for contamination of surface and groundwaters due to the activities of the copper industry varies widely depending on a variety of site-specific factors. The considerations discussed in box 8-D, and the chance that potential problems may not be identified by the current RCRA characterizations of wastes, led the EPA to believe that entirely different criteria may more appropriately identify the mining wastes most likely to be of concern.<sup>32</sup>

<sup>30</sup>Regulatory Determination for Wastes from the Extraction and Beneficiation of Ores and Minerals, Federal Register, July 3, 1986.

<sup>31</sup>SCS Engineers, *supra* note 27.

<sup>32</sup>Federal Register, *supra* note 30.

## Waste Management Practices

**In the great majority of cases, potential adverse impacts from copper wastes can be controlled to acceptable levels with established waste management practices (see figure 8-7).**

These practices can be summarized in three main categories: 1) minimization, collection, and treatment of mine drainage, mill process water, and contaminated surface drainage; 2) handling, storage, and ultimate disposal of tailings and waste rock; and 3) reclamation of the site to minimize long-term environmental effects once active mining has ceased. <sup>33</sup>Waste reprocessing and utilization is a fourth method that could offer many advantages over disposal, but the enormous volumes of waste preclude this from being a viable alternative to disposal.

### Collection and Treatment of Liquid Wastes

Disposal of liquid wastes is rarely a problem as most water can be treated (if necessary to remove contaminants that would interfere with its use) and recycled for drilling, dust control, or process water at the mill. Indeed, such recycling can augment water supplies in the arid and semi-arid Southwest. Water containing relatively high concentrations of soluble metals can be used in the flotation circuits, which will precipitate the metals. Total suspended solids (including metals) in wastewater are controlled by building sediment control ponds, in which the water is held long enough for most of the sediment to settle. Sedimentation ponds must be designed with respect to predicted frequency and volume of discharge; a series of settling ponds can be used to improve the entrapment of sediment.

**Mine Water.**—Water can accumulate in surface mines and underground shafts due to hydraulic backfill operations; groundwater seepage into the mine; water use for machine operations including drilling, dust suppression, cooling, and air conditioning; sanitation and drinking water; and direct rainfall. Volumes vary widely depend-

<sup>33</sup>Alan v. Bell, "Waste Controls at Base Metal Mines, *Environmental Science and Technology*, vol. 10, No. 2, February 1976, pp. 130-135.

### Box 8-D.—Factors Affecting the Potential for Contamination

**The Location of the Site.**—Sites well removed from urban areas, drinking water supplies, surface waters, and sensitive ecosystems are not likely to pose high risks. Most active U.S. copper operations are in sparsely populated, arid areas where the transport of contaminants is limited by the scant annual precipitation.

**The Climate.**—Surface infiltration to groundwater is limited in arid and semiarid regions with little surface water. Almost 80 percent of copper sites are located in areas with a net annual recharge of less than two inches.<sup>1</sup> However, heavy storms could cause some leaching of the waste and result in acid flushes to the surrounding area.

**The Hydrogeology of the Site.**—The geologic structure of subsurface and related surface water systems may prevent contamination by effluents. For example, aquifers may be protected from effluents by thick layers of alluvium deposits or an impervious clay cap. EPA studies indicate that 70 percent of all mine waste sites (including copper) have groundwater depths greater than thirty feet, so there is time for the soil to mitigate any seepage that might occur. Other formations such as bedrock may divert effluents.

**The Buffering Capacity of Soil.**—Some copper ores in the southwestern United States are embedded in host rock of sedimentary limestone (calcium carbonate,  $\text{CaCO}_3$ , is the chief constituent of limestone). As the effluent passes over or through limestone formations, it is partially neutralized, the pH increases, and some of the metals will precipitate out of the solution. The buffering capacity of limestone degrades over time. Other copper ores are formed in acid igneous deposits in which calcareous minerals are rare and acid formation potential is correspondingly high.

**Removal Mechanisms in Surface Waters.**—Alkalinity is described as the ability of water to neutralize acid. Bicarbonate ( $\text{HCO}_3^-$ ) and carbonate ( $\text{CO}_3^{2-}$ ) from adjacent limestone and feldspar formations are the principal sources of alkalinity in most surface waters. Alkalinity also tends to precipitate metals. Conditions may arise later that will re-solubilize the metals, however, and they can become a source of low level, nonpoint pollution for years to come. The real extent of the pollution is determined by the volume and velocity of the receiving waters. As with buffering by soils, the alkalinity of surface waters is finite.<sup>2</sup>

<sup>1</sup>Recharge is the flow of water into subsurface areas, either from infiltration by precipitation or transport from adjacent groundwaters.

<sup>2</sup>Harry W. Martin and William R. Mills, *Water Pollution Caused by Inactive Ore and Mineral Mines—A National Assessment*, prepared for the EPA, December 1976.



Photo credit Jenifer Robison

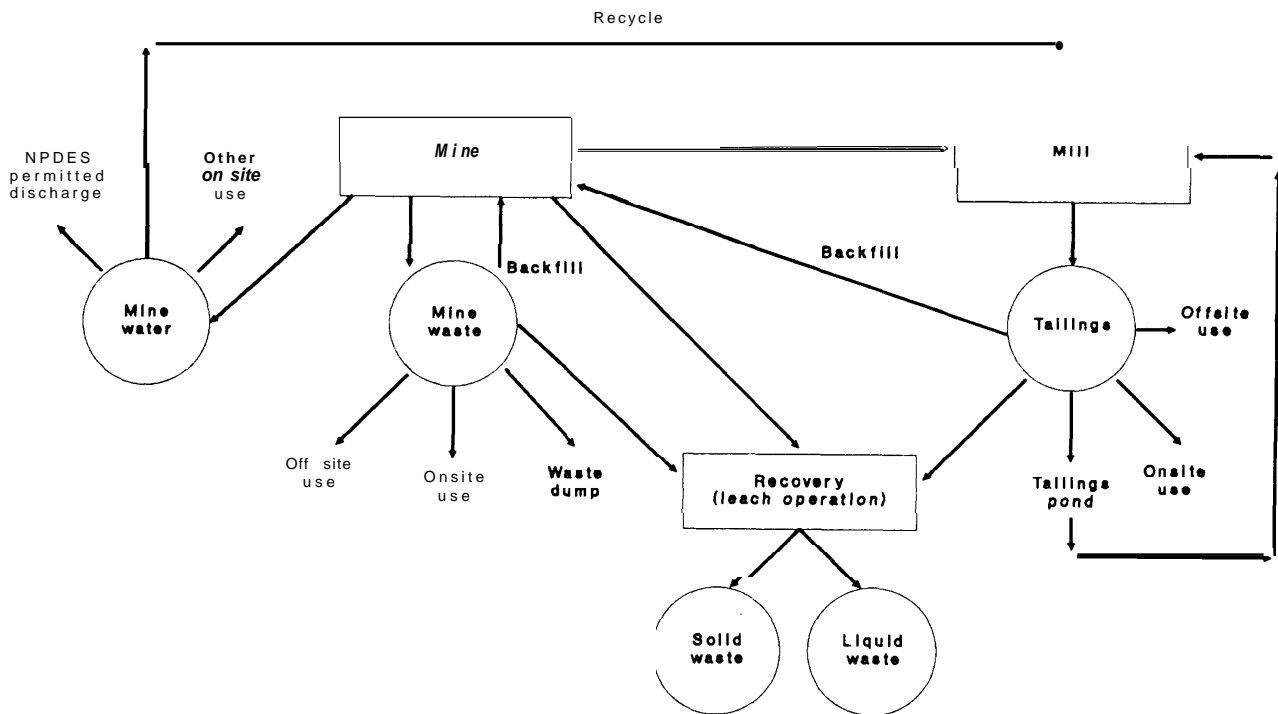
The arid climate, low population density, and other features of the Southwest mitigate the potential for surface and groundwater impacts from copper mining.

ing on mining methods, the climate, and the hydrogeological characteristics of the region.<sup>34</sup> Excess water usually is stored in natural drainage areas or in surface impoundments where it evaporates or is later used as process water.

**Mill Process Water.**—Water use in froth flotation is high (in Arizona, about 126,000 gallons per ton of copper produced); around 80 percent is recycled. Occasionally, a buildup of reagents in the process water will interfere with flotation, and it becomes necessary to discharge and replace the water. Any discharge is required to meet effluent limitations.

<sup>34</sup>Ibid.

Figure 8-7.-Wastes and Management Practices



SOURCE: U.S. Environmental Protection Agency, *Wastes from the Extraction and Beneficiation of Metallic Ores, Phosphate Rock, Asbestos, Overburden from Uranium Mining and Oil Shale*, report to Congress, December 1985.

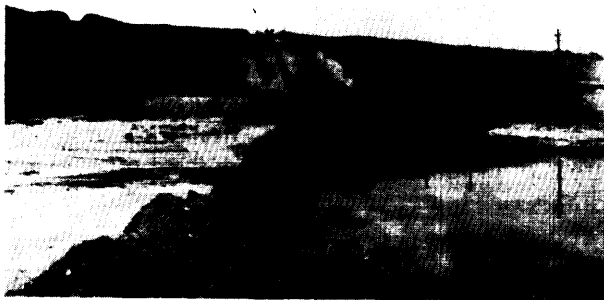


Photo credit: John E. Robison

Sediment control pond

**Smelting and Refining.—Guidelines** are being developed for effluents discharged from primary copper smelters, electrolytic copper refineries, and metallurgical acid plants. These limitations aim to control the amount of arsenic, cadmium,

copper, lead, zinc, and nickel in effluents; the pH of the discharge; and the concentration of total suspended solids. Treatment of wastewater from these sources is similar to that described above for mines and mills.

**Leachate.—The seepage and leaking of sulfuric acid solutions could contaminate both surface and groundwater.** However, this potential is offset by the miner's interest to collect as much of the copper-bearing leachate as possible. Leachate collection systems include hydraulic draws that exploit the natural slopes of the area, sumps located beneath the heap/dump, or a more sophisticated pumping system with secondary leachate collection to control contamination. Older operations generally do not have protective liners, and experience some loss of leachate. New leaching operations use impermeable membranes to confine leach solutions and channel them to a collection pond.<sup>35</sup>

<sup>35</sup>Stephen F. Walsh, "The San Manuel Oxide Open Pit Project," Presented to the Arizona Conference of AIME, Dec. 9, 1985.

## Handling and Storage of Solid Wastes

As noted previously, solid wastes are generated during mining and milling, as well as smelting and converting. The primary pollution problem is the potential for sulfide minerals to form sulfuric acid, which in turn is capable of leaching metals from the wastes and the surrounding formations and transporting them to surface and groundwater systems.

**Mine Waste.**—Copper mining generates large volumes of waste rock and dirt, either from the material overlying the deposit (overburden), rock removed from underground mines while sinking shafts, ore that is too low in grade to be commercially valuable, and the rock interbedded with the ore body.<sup>36</sup> This distinguishes mining from many other process industries where wastes are a relatively small portion of the total materials used to produce a final product. Indeed, larger mines handle more material and generate more waste than many entire industries.<sup>37</sup>

Although mine waste makes up the largest fraction of total solid waste from copper production, it has fewer stability and environmental problems than other solid wastes.<sup>38</sup> The waste typically is dumped in a pile near the mine site by the truck-

<sup>36</sup>U.S. EPA, *supra* note 29.

<sup>37</sup>Federal Register, *supra* note 30.

<sup>38</sup>C. W. Center et al., *Development of Systematic Waste Disposal Plans for Metal and Nonmetal Mines*, Goodson and Associates, Inc., Aurora, Colorado, Prepared for the Bureau of Mines, June 1982, p. 14.

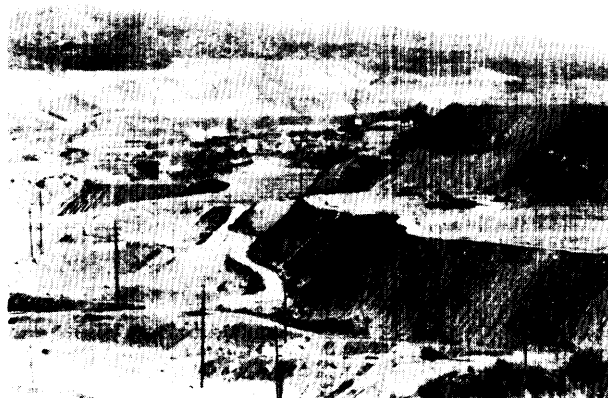


Photo credit Jenifer Robison

Copper mining generates large volumes of waste rock and dirt.

load. This usually produces steep slopes and some segregation of particle sizes, with the larger sizes relegated to the bottom of the coarse material. There may be some deliberate segregation of the waste to stockpile low grade ore for leaching operations.

**Leach Waste.**—Once leaching is discontinued, the heap/dump becomes leach waste, which can release acidic effluents, toxic metals, and total dissolved solids to the surrounding area. If the leach pile is in a recharge area, groundwater contamination could occur. The liners used in new leaching dumps continue to provide groundwater protection after closure, but older, unlined dumps may degrade surface and groundwater if steps are not taken to contain or prevent seepage.

**Tailings.**—Tailings differ from mine and leach waste in that they are very fine and they retain a certain amount of water after disposal. Fine particle sizes tend to liberate more contained toxics at a faster rate than coarser wastes. If future advances in processing include grinding ore more finely to increase metal recovery, tailings disposal will become even more complicated.

Seasonal or intermittent releases due to heavy rainfall and continuous seepage from groundwater infiltration are the most common mechanisms of tailings transport. Seepage can flush sulfates, dissolved solids, trace metals, and organics into groundwater. In older tailings, heavy rains can oxidize pyritic minerals and form an acidic effluent that is capable of mobilizing residual metals. Arsenic, cadmium, and lead are the toxics most frequently released from tailings ponds, although other trace metals such as copper, gold, silver, and zinc also may be released.<sup>39</sup>

**Miscellaneous Sludges and Dusts.**—In this group of wastes, the sludges generated by sulfide precipitation (followed by sedimentation) are of greatest concern; EPA believes these will be classified as hazardous under RCRA, and considers the potential control costs achievable.<sup>40</sup> Other

<sup>39</sup>SCS Engineers, *supra* note 27.

<sup>40</sup>Nonferrous Metals Manufacturing Point Source Category: Effluent Limitations Guidelines, Pretreatment Standards, and New Source Performance Standards; Final Rule, Federal Register, vol. 49, No. 47, Mar. 8, 1984.



Photo credit: Jenifer Robison

Copper tailings have a much finer texture than mine wastes.

miscellaneous wastes include sludges from acid plants (blowdown) and dusts from converters and reverberatory furnaces. Volubility tests have found these can leach copper, lead, zinc, and cadmium. They also contain antimony, arsenic, chromium, mercury, nickel, selenium, and silver. Slimes recovered from electrorefining cells tend to be rich in selenium, tellurium, arsenic, gold, silver, and platinum. The precious metals are recovered from the slime, but significant leaching of hazardous constituents from electrolytic refining lagoon sediments is also possible. These sediments settle from a combined slurry composed of effluents from spent electrolyte as well as contact cooling of furnaces, spent anode and cathode rinse water, plant washdown, and wet air pollution control.

## Reclamation

Reclamation of tailings and mine waste dumps attempts to restore the area to a productive land use after closure and to provide long-term environmental protection. The land use is usually restricted to a self-sustaining vegetative cover that protects the surface from erosion<sup>41</sup> Because most tailings transport mechanisms depend either directly or indirectly on water, reclamation techniques often focus on controlling and diverting water.

<sup>41</sup> Richard C. Barth, "Reclamation Technology for Tailings Impoundments Part 1: Containment," *Mineral and Energy Resources*, vol. 29, No. 1, January 1986, p. 2.

Tailings transport due to wind erosion also can be a serious problem, especially when the tailings are inactive and dry out. Ambient air standards for total suspended particulate have been violated due to the heavy loading of tailings in the atmosphere.<sup>42</sup> This erosion can be controlled by watering the tailings, maintaining a vegetative cover, applying a chemical sealant, or covering the tailings with waste rock or slag. In arid climates, waste rock covers are more frequently used because revegetation is difficult and expensive.

One reclamation technique common to all tailings and waste dumps is the application of a layer of topsoil or alluvial material to protect seedlings from glare and supply essential nutrients and microorganisms. This technique can be expensive; some topsoiling efforts have exceeded **\$65,000** per acre. Asarco has managed to top-

<sup>42</sup>George J. Schewe, *Monitoring and Modeling Analyses of the Kennecott Corporation Smelter in McGill, Nevada*, PEDCo Environmental Inc Cincinnati, Ohio, March 1981,

soil their Arizona tailings successfully for an average cost of \$2,500 per acre.<sup>43</sup>

### Waste Reprocessing and Utilization

Tailings may be reprocessed to recover additional metals. This method may be particularly rewarding when dealing with older tailing piles from much less efficient beneficiation processes. Tailings also may be used onsite for mine backfill. There has been extensive research into the possibility of upgrading tailings to a salable product such as building materials (e.g., glass and bricks). However, tailings often are unsuitable for such materials because they are too fine, have poor drainage properties, and can be thixotropic (turn liquid when shaken).<sup>44</sup>

<sup>43</sup>Stuart A. Bengson, "Asarco's Revegetation of Mill Tailings and Overburden Wastes from Open Pit Copper Mining operations in Arizona," paper presented at the National Meeting for the American Society for Surface Mine Reclamation, Oct. 8-10, 1985, Denver, CO.

<sup>44</sup>C.G. Down and John Stocks, "Positive Uses of Mill Tailings," *Mining Magazine*, September 1977 pp. 213-223



**Part Four**

# **Competitiveness**

Chapter 9

# Production Costs

# CONTENTS

	<b>Page</b>
Cost Concepts and Definitions . . . . .	185
Structural Factors Affecting Costs . . . . .	186
Ore Grade . . . . .	186
Byproducts . . . . .	187
Other Geological Characteristics . . . . .	187
Scale of Production . . . . .	188
Leadtime and Life Span . . . . .	191
Capital and Energy Intensities . . . . .	192
Location and Weather . . . . .	192
Infrastructure. . . . .	193
Public Profile. . . . .	193
Worker Compensation . . . . .	193
Costs and Technologies. . . . .	194
Mining Methods . . . . .	194
Smelter Technologies . . . . .	195
Leaching and Solvent Extraction- Electrowinning. . . . .	196
Costs of Major Copper Producers, 1986..	197
Overview . . . . .	197
1986 Producer Profiles . . . . .	199
Cost Changes in the Early 1980s . . . . .	209
Expansions and Contractions . . . . .	210
Byproduct Prices . . . . .	210
Macroeconomic Trends . . . . .	210
Real Cost Improvements . . . . .	211
Summary . . . . .	215
Cost Trends and Outlook . . . . .	216
New Project Development . . . . .	216
Real Cost Trends.. . . . .	216
Long-Term Availability Costs . . . . .	216

## Boxes

<b>Box</b>	<b>Page</b>
9-A. Byproduct Accounting. . . . .	187
9-B. Relative Purchasing Power of Currencies . . . . .	212

## Figures

<b>Figure</b>	<b>Page</b>
9-1. Capacity Profile of <b>Non-Socialist</b> World Copper Production, 1986.....	189
9-2. Principal Stages of the Copper Production Process . . . . .	190

<b>Figure</b>	<b>Page</b>
9-3. operating Costs of Major Non-Socialist Copper Producers, 1986 . . . . .	198
9-4. Corporate Costs of Major Non-Socialist Copper Producers, 1985 . . . . .	199
9-5. Costs and Capacity of Non-Socialist Copper Production, 1981 &1986 ....	210
9-6. Purchasing Power of Currencies Relative to \$U.S., 1981-86.....	213
9-7. Corporate Costs of Major Non-Socialist Copper Producers, 1980& 1985.....	215
9-8. Long Term Costs and Capacity of Selected Producers . . . . .	217

## Tables

<b>Table</b>	<b>Page</b>
9-1. Financial Evaluation of Smelter Alternatives Considered for the Chino Modernization . . . . .	191
9-2. Capital Costs of Copper Projects. ....	192
9-3. Production Costs of Several Chilean Copper Smelters . . . . .	195
9-4. Production Costs for Major Non-Socialist Copper-Producing Countries . . . . .	197
9-5. Cost and Structural Profiles of Major Non-Socialist Copper-Producing Countries . . . . .	200
9-6. Major U.S. Copper Mines: Ownership, Locations, and Capacities in 1986 . . . . .	202
9-7. Vi/age and Electricity Rates in the Copper Industry . . . . .	204
9-8. Byproduct Prices . . . . .	211
9-9. Exchange Rates and Price Levels for Major Copper-Producing Countries, 1980-87 . . . . .	214
9-10. Gross Corporate Costs of Major Copper producers. . . . .	214
9-11. Operating and Availability Costs for Major Copper-Producing Countries . . . . .	218

# Production Costs

**Low costs are the fundamental source of competitive strength in the copper industry.** They lead to profitability, which in the United States is the principal measure of an industry's competitiveness.<sup>1</sup> **High prices also lead to profitability, but copper prices are established by the mar-**

<sup>1</sup> The term "competitiveness" also refers to various other measures of industrial health, including domestic market share, world production share, foreign exchange earnings, exports, sales, employment, productivity, innovative potential, and sensitivity to price declines (see ch. 10). In other countries, one or more of these goals may prevail over profitability.

**ket and difficult to control.**<sup>2</sup> Individual copper producers, therefore, focus on cost reduction as the primary means to improve their competitiveness. This chapter describes the structural and technological factors that influence copper production costs, examines the costs of major world producers as of 1986, analyzes the cost changes of the early 1980s, and assesses the prospects for future cost competitiveness.

<sup>2</sup> The numerous producers, minimal product differentiation, and efficient world trading system that characterize the copper market result in many potential suppliers, and thus competitive pricing, in most facets of the market.

## COST CONCEPTS AND DEFINITIONS

A company's first concern is keeping its costs below the prevailing price of copper. Changes in wages, productivity, and other operating factors make this a constant challenge. An additional concern is that the costs are held below those of other producers. Keeping costs comparatively low improves a company's prospects of competing during periods of oversupply. Fluctuations in exchange rates and inflation rates greatly influence a producer's comparative (or relative) cost position.

The short-term costs that producers face include operating, administrative, and debt service expenses. Over the long term, there are the additional expenses of replenishing the resource and capital bases, and giving the owners and investors a continuing return commensurate with the risk of their investment. The copper industry uses several cost measures; the most common are operating costs, corporate costs, and availability costs.<sup>3</sup> Each gives a different picture of the

<sup>3</sup> Two other important cost measures, avoidable and hard currency costs, are not covered in this chapter because of data limitations. Avoidable (or variable) costs are the corporate costs minus the fixed charges that would be incurred during a temporary closure. They indicate the price at which a producer might decide to halt production in the short term. Differing business environments and priorities may cause labor, electricity, or other costs to be fixed for one producer, but variable for another. This helps to explain why, when demand declines and prices drop, some cop-

per producers cut back while others continue to operate at near full capacity. Hard currency costs are the portion of corporate costs that are incurred in currencies that are internationally convertible. They define the price at which a facility that has foreign exchange generation as a major goal will shut down in the short term.

**Operating costs** are the physical costs of producing copper: the direct and indirect costs incurred in mining, concentrating, smelting, and refining copper. They include transportation to the mill, smelter, and refinery, and metallurgical processing of the byproducts. Some estimates of operating costs also include the freight charges for transporting the refined copper to market.<sup>4</sup> Direct costs embody direct and maintenance labor, energy, materials, payroll overhead, and utilities. Indirect costs include supervision, site administration, facilities maintenance and supplies, research, and technical and clerical labor. Excluded from operating costs are corporate overhead, deferred expenses, depreciation, insurance, debt interest payments, and taxes. Two subcategories are used to highlight the role of by-

<sup>4</sup> In this chapter, the cost data from Brook Hunt & Associates Ltd. include freight to market, but the data from the Bureau of Mines do not.

products, *Gross operating costs* equal the sum of all direct and indirect costs, and *net operating costs* equal these same costs less the revenues from the sales of byproducts.

Corporate costs are the operating costs plus corporate overhead, deferred expenses, insurance, debt interest payments, and taxes. They specify the minimum price at which an operation shows short-term profits (i.e., breaks even).

**Availability costs** are the corporate costs plus resource and capital replenishment expenditures (i.e., depreciation) and the return on the invest-

ment of the owners and investors. They define the price that provides sufficient incentive for sustained production by the firm. Thus, they are a measure of a producer's chances for long-term profitability.

Unless noted, all costs and prices appearing in this chapter are stated in nominal U.S. dollars (\$) or cents (¢). All ¢/lb cost figures are based on the amount of refined copper ultimately recovered from the entire processing sequence. Most are averages (weighted according to amount of recovered copper) for multiple producers.

## STRUCTURAL FACTORS AFFECTING COSTS

**Copper production is characterized by capital expenditures that are large and risky, and production costs that are highly sensitive to ore grade, energy prices, wage rates, and financing terms.** These features arise from structural factors that are common to many copper and other base metal projects: 1) low and declining ore grades; 2) nonuniform distribution of byproducts; 3) variations in other geological characteristics; 4) large and growing scales of production; 5) long leadtimes and life spans of projects; **6) high and increasing capital and energy intensity of production methods; 7) remote locations with frequently inclement weather; 8) considerable infrastructure requirements; 9) high public profiles of the operations; and 10) high compensation paid to workers.**

### Ore Grade

**The costs of mining and processing copper are more closely related to the gross tonnage of the ore than the net tonnage of copper in the ore.**<sup>5</sup> A tonne of lean ore requires no more capital, energy, labor, and supplies to mine than a tonne of rich ore. However, because the rich ore contains more copper, it requires less of these inputs per tonne of copper recovered. The gross tonnage basis for costs is particularly important in the copper industry, because ore grades are very

low (often **0.5 to 2.0 percent Cu**). **At these low levels, small differences in ore grade represent large variations in the tonnages of ore that are handled for each tonne of copper recovered, and in turn large variations** in the mining and milling costs.

At most properties, ore is mined and blended with a view to maintaining a uniform mill-head grade for efficient milling and concentrating. However miners can, and do, adjust the grade in several ways to adapt to changing economic conditions or technological developments. They may raise the mill-head grade by selective mining of high-grade areas in a mine.<sup>6</sup> They also may change the cut-off grade (the lowest grade that is mined and treated). These are very important decisions in the operation of a mining project. They must be considered in the context of the prevailing copper price, the health of the firm, and the mine plan. Such actions ultimately affect the overall output of the mine and are therefore not undertaken capriciously.

Ore grades decline over time, despite occasional discoveries of high grade deposits. This occurs both for the world's reserves as a whole and for each mine's orebody. Richer reserves are exploited first in order to recoup capital investments. Some mines have a cap of high grade ore

<sup>5</sup>Simon D. Strauss, *Trouble in the Third Kingdom* (London: Mining Journal Books, 1986).

<sup>6</sup>Janice L. W. Jolly, "Copper," *Mineral Facts and Problems*, 1985 edition (Washington, DC: U.S. Department of the Interior, Bureau of Mines, 1985).

covering deeper, leaner ores. When possible, poorer grades are left for later extraction with the hope they will become viable as technologies improve. The ores mined in the United States in the late 1800s were approximately 2 percent copper; today's grades are closer to 0.5 percent copper.

The upward cost pressure of global and local ore grade depletion historically has been addressed through larger facilities and equipment (to spread the fixed charges across a greater output) and improved technology and management. These responses have more than offset the decline in ore grades, so production costs have fallen over the long term.

### Byproducts

Copper is usually not the only product of copper mines. <sup>7</sup>**Often molybdenum, lead, zinc, gold, or silver, and sometimes nickel or cobalt are also extracted from copper ore. These minerals can be either byproducts or co-products. They are co-products if they are so prevalent that their production depends on their own price, and byproducts if they are produced regardless of their own price.** In either case, their production depends to some extent on the price of the primary product, copper. At some mines, it is copper that is the byproduct and produced with little regard to its price. In the remainder of this chapter, no distinction is made between byproducts and co-products, and the term "byproduct" is used for both.

**Byproduct values** fluctuate with their prices and vary considerably from deposit to deposit. They **play a major role in the economics of many copper projects, and dramatically affect the overall world competitiveness picture.** Byproducts are a favorable asset to any operation, despite the extra costs incurred in their separation and processing.

From a cost standpoint, byproduct revenues are usually considered credits (i.e., negative costs) (see box 9-A). The analysis presented in the suc-

<sup>7</sup>Copper-only operations are actually in the minority. According to Brook Hunt & Associates Ltd. cost estimates, only about 40 percent of Non-Socialist World copper production is from mines where copper accounts for over 90 percent of revenue.

#### Box 9-A.—Byproduct Accounting

When a mine or a plant produces multiple products, cost allocation becomes a problem. How much of the cost of mining or processing is for the copper, and how much is for the gold, silver, etc. ? Prior to the separation of the various products, the costs are joint. No method of allocating joint costs to the various products is universally accepted. The most common method charges all production costs to the copper, and subtracts the revenues from the sales of the byproducts from the copper accounts. Thus, from an accounting viewpoint, copper is very expensive to produce while the other products are a windfall. This accounting scheme has the advantage of simplicity over methods which allocate costs among products based on their value, but it has drawbacks. First, it yields misleading productivity figures. All the labor, energy, supplies, etc. that go into minerals extraction (byproducts as well as copper) are attributed to copper. This gives the appearance of very poor productivity in terms of factor use per tonne of copper. Second, byproduct revenues are tied directly to the prices of their respective commodities and thus fluctuate greatly. Handling the revenues as essentially negative costs gives the cost picture unwarranted volatility. Factor costs are actually somewhat stable, it is revenues that fluctuate. Considered from a revenue perspective, byproducts are a type of diversification that should decrease, not increase, the volatility of a project's financial picture.

ceeding sections shows that some mines have very substantial byproduct credits. In 1986, the average byproduct revenues at mines in Zaire and Canada offset their gross costs by 49 and 35 percent respectively. Byproduct credits of these magnitudes greatly diminish the influence of copper market signals, such as price, on those producers' behavior. Major decisions regarding exploration, investment, expansion, and shutdown become tied to the events in several markets, not just the copper market.

#### Other Geological Characteristics

Ore grades and byproducts are not the only geological features that influence costs. **The amount of waste that must be moved (stripping**



Photo credit: John E. Robison

Open pit mining involves moving huge amounts of ore and waste. Moreover, mines grow deeper and/or wider as they age, increasing haulage costs.

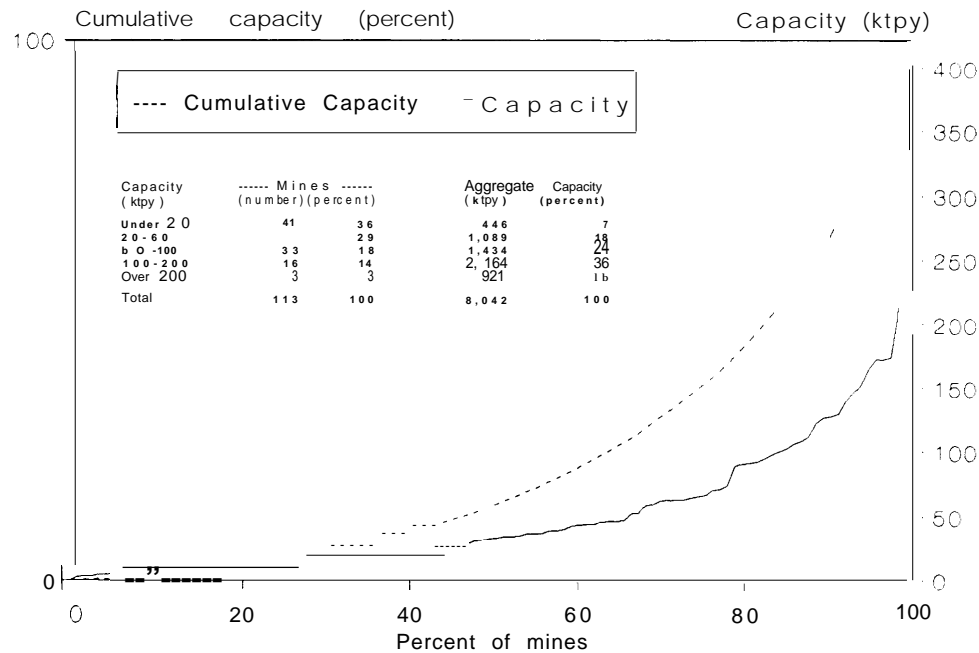
ratio), the hardness of the ore and the complexity of its minerals, and the size of the mine are also important. Stripping ratios vary from below 1:1 (waste:ore) at some mines to greater than 10:1 at others. This range represents great differences in the amounts of material that must be moved and large variations in the costs of operations. An ore's hardness and mineral complexity are important factors in the ease of its beneficiation. Softer ores are easier and less expensive to grind; simpler ores are more amenable to flotation. Lastly, both open pit and underground mines grow larger (wider and/or deeper) as they age. The increasing size entails moving the material longer distances. **The declining ore grades, higher stripping ratios, and greater haulage distances that occur over time work to raise operating costs and mines must find ways to offset these cost pressures (see ch. 5).**

## Scale of Production

Although there are many small copper mines, the major producers are quite large. **New projects are being built larger and existing operations are being expanded to lower costs by spreading the fixed charges across greater output.** In a recent Bureau of Mines survey, of 113 **copper properties producing in 1986 (accounting for 88 percent of Non-Socialist World —NSW—production), almost two-thirds of the operations had capacities in excess of 20 thousand tonnes per year (ktpy) refined copper<sup>8</sup> (see figure 9-1). Nineteen of the mines in this survey had capacities greater**

<sup>8</sup>Kenneth E. Porter and Paul R. Thomas, "The International Competitiveness of United States Copper Production," to be published in *Minerals Issues- 1988* (Washington, DC: U.S. Department of the Interior, Bureau of Mines, 1988).

**Figure 9-1.-Capacity Profile of Non-Socialist World Copper Production, 1986**



SOURCE: OTA from Bureau of Mines data

than 100 ktpy, the largest being Chuquicamata (421 ktpy) and El Teniente (293 ktpy) in Chile, and Nchanga (207 ktpy) in Zambia.<sup>9</sup>The largest U.S. mines are Morenci-Metcalf (172 ktpy) and San Manuel (108 ktpy).<sup>10</sup>

Mining, milling, smelting, and refining operations of this magnitude handle great amounts of material and generate large amounts of waste. A typical 100,000 tonne per year (tpy) copper operation moves 15 to 35 million tpy of overburden rock, mines and mills about 15 million tpy of ore, smelts about 300,000 tpy of concentrate, refines 100,000 tpy of blister, and may process 180,000 tpy of offgas to produce 270,000 tpy of

sulfuric acid<sup>11</sup>(see figure 9-2). Processing and handling these vast quantities of material requires costly equipment and large amounts of energy. In addition, the mine and mill consume great amounts of water, and the operation as a whole generates enormous amounts of waste (overburden, tailings, and offgases). These features can require costly environmental control (see ch. 8).

<sup>11</sup>The materials balance of a conventional, open pit copper Production operation is as follows:

$$\begin{aligned} \text{Blister Refined} &= \text{Copper Produced} \times \frac{\text{Refined Grade}}{\text{Refinery Recovery} / \text{Blister Grade}} \\ \text{Concentrates Smelted} &= \text{Blister Refined} \times \frac{\text{Blister Grade}}{\text{Smelter Recovery} / \text{Concentrate Grade}} \\ \text{Ore Mined \& Milled} &= \text{Concentrates Smelted} \times \frac{\text{Concentrate Grade}}{\text{Mill Recovery} / \text{Ore Grade}} \\ \text{Overburden Rock Moved} &= \text{Ore Mined \& Milled} \times \text{Stripping Ratio} \end{aligned}$$

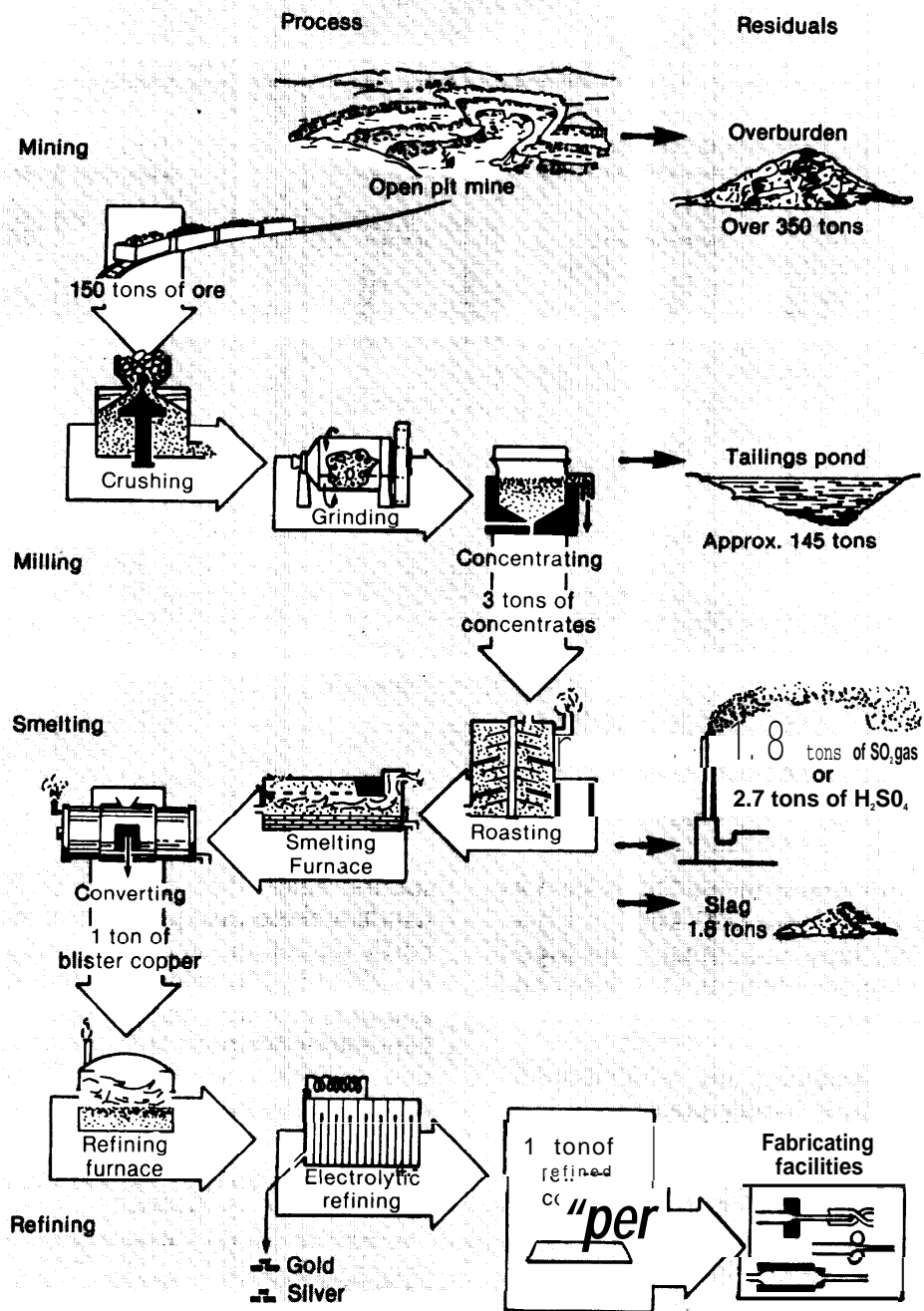
Common values for the operating parameters are: Refined Grade (99.99 percent); Refinery Recovery (99 percent); Blister Grade (98 to 99 percent); Smelter Recovery (95 to 98 percent); Concentrate Grade (25 to 40 percent); Mill Recovery (75 to 95 percent); Ore Grade (0.5 to 2.0 percent); and Stripping Ratio (1:1 to 2.5:1).

<sup>9</sup>In this chapter, all "ktpy" figures for specific mines relate to their production at full capacity.

<sup>10</sup>The Bingham Canyon pit was not included in the Bureau of Mines survey, because it was closed for much of 1986 for modernization. After modernization, its capacity will be around 200 ktpy.



Figure 9-2.— Principal Stages of the Copper Production Process



NOTE: Tonnage of residuals is based on experience in the Southwestern United States assuming an ore grade of 0.6 percent copper.

SOURCE: J.F. McDivitt and G. Manners, *Minerals and Men* (Baltimore, MD: The Johns Hopkins University Press, 1974)

**The strategy of expanding existing mines has limits.** The bench width in open pit mines or the rock strength and drift dimensions in an underground mine may not be able to accommodate the newer, larger equipment.<sup>12</sup> Recently, small scale leaching and solvent extraction-electrowinning (SX-EW) units have been developed that make small, short-lived operations possible. However, this equipment is not expected to reverse the general trend to larger scale projects.

**Leadtime and Life Span**

Developing new copper production capacity or expanding existing facilities is not only costly, but also time consuming. Expansions take a year or more, and new facilities require 1 to 15 years of exploration and 2 to 5 years of development. Once built, facilities typically operate for decades. Several major domestic mines have been in operation since the early 20th century; Bingham Canyon (1907), Ray (191 1), Chino (191 1), and Inspiration (191 5). Over 80 percent of U.S. capacity in 1986 was built before 1960.

Economic conditions—and the profitability of a minerals operation—can change drastically during the long leadtimes and life span. Longer leadtimes reduce the certainty of project feasibility and raise the risk.

The uncertain prices and high capital costs encountered over the life of a mine or plant tend to make managers very conservative in their investment decisions. Managers in the mining industry are noted for their reluctance to invest in unproven technologies because of their risk. Moreover, it is extremely difficult to keep successful innovations proprietary. Technology transfers easily and quickly in the copper industry, so little gain accrues to the operation that tries a new technology first.<sup>13</sup>

Managers also are known for their tendency to repair, rebuild, and retrofit, rather than replace, their equipment.<sup>14</sup> Equipment replacement is

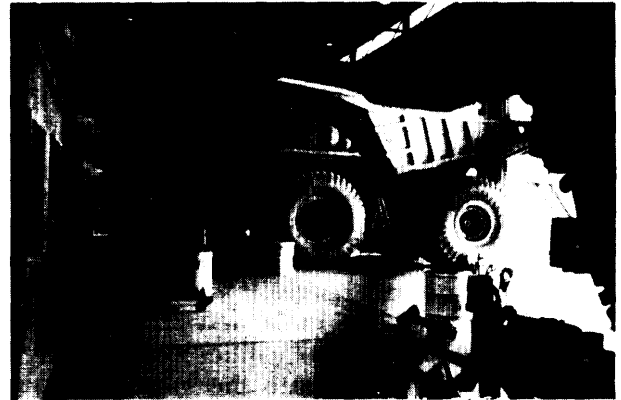


Photo credit: Robert Niblock

**Mining equipment** is more often repaired rather than replaced, due to the capital and operating costs of introducing new technology.

avoided because of the capital costs, startup inefficiencies, and mining and processing plan revisions. More often, worn out or obsolete equipment is repaired, rebuilt, or retrofitted, sometimes for 40 or 50 years. Retrofitting minimizes risk in the short term, but can lead to missed cost savings in the long term. Table 9-1 shows the financial evaluation of three plans considered for modernizing the Chino smelter. The options considered were: 1) installing an INCO flash furnace; 2) retrofitting the existing reverberatory furnace; and 3) shutting down the plant. Installation of the flash furnace cost \$67 million more than retrofitting the reverberatory furnace, but had a much higher rate of return.

and risk of proving new technology on a large scale, the impact of some restrictive government regulatory policies, and the questionable investment future of the industry resulting from current (1984) economic conditions have contributed to a conservative industry reliance in its operations on proven uniform technology developed outside of industry." U.S. International Trade Commission, *Unwrought Copper*, report to the President on Investigation No. TA-201-52, USITC Publication No. 1549, July 1984.

**Table 9-1.—Financial Evaluation of Smelter Alternatives Considered for the Chino Modernization**

	Incremental capital (\$ million)	Incremental rate of return (percent)
INCO plan v. shutdown . . . . .	99	23
Retrofit v. shutdown . . . . .	32	17
INCO plan v. retrofit . . . . .	67	26

SOURCE: R.D. Wunder and A.D. Trujillo, "Chino Mine Modernization," *Mining Engineering*, September 1987, pp. 887-872.

<sup>12</sup>William c, Peters, *Exploration and Mining Geology* (New York, NY: John Wiley & Sons, 1978).

<sup>13</sup>The ease and speed of technology transfer comes from the general openness in the industry and the fact that technologies are developed primarily by the equipment vendors (see ch. 10).

<sup>14</sup>The special nature of the metals commodity market, the large capital investments in existing productive capacity, the high costs

## Capital and Energy Intensities

Mineral mining and processing methods are becoming increasingly mechanized, because of the cost pressures described in the preceding sections. Newer facilities thus rely more heavily on capital and energy and less on labor.<sup>15</sup> Producers are building large-scale, capital-intensive operations that have low variable costs, but high fixed costs and financial charges.<sup>16</sup> **The rising capital requirements not only make new projects or the modernization of older facilities expensive (see table 9-2), but accentuate the importance of financing terms,** such as interest rates, payback schedules, guarantees, etc. on a firm's balance sheet. Discrepancies among various producers' costs of capital (because of concessional financing from multilateral development banks, loan guarantees from governments, or interest rate reductions on renegotiated debt) are therefore the subject of constant industry concern (see ch. 3).

The rising capital intensity also decreases the avoidable (or variable) costs of the minerals business. This reduces its operating flexibility, and means that ever lower prices are required to force production cutbacks.

<sup>15</sup> "To achieve a given level of sales revenue, a mining project requires more capital than a venture of comparable size in either manufacturing or the retail trade." Strauss, supra note 5.

<sup>16</sup> Kenji Takeuchi et al., *The World Copper Industry* (Washington, DC: World Bank staff commodity working papers, No. 15, 1987).

The increasing reliance on energy-intensive production methods accentuates the importance of oil prices and electricity rates for production costs (see ch. 7). Energy accounts for about one-quarter to one-third of crushing costs.<sup>17</sup> In smelting, energy often accounts for over one-half of production costs. As large users of electricity (and important sources of revenue for utilities), copper producers can sometimes negotiate concessional rates. Such contracts, however, are often written on a take-or-pay basis, adding further to the industry's fixed costs.

## Location and Weather

Geology fixes the location of mineral resources; economic deposits do not exist everywhere. Mines must be located where the ores are, and mills must be nearby to minimize the cost of transporting the great tonnages of ore. Smelters need not be close to the orebody, because concentrates contain 25 to 40 percent copper and are much less costly to transport. <sup>18</sup>

**Many mines and mills are located in remote areas, often in the mountains and subject to occasional severe weather conditions.** These fea-

<sup>17</sup> United Nations Industrial Development Organization (UNIDO), *Technological Alternatives for Copper, Lead, Zinc, and Tin in Developing Countries*, document ID/WG.470/5, 1987.

<sup>18</sup> In fact, there is a great deal of trade in concentrates (see ch. 4). Also, the sulfuric acid market is playing an increasing role in decisions regarding the location of smelters.

**Table 9-2.—Capital Costs of Copper Projects (in nominal \$U.S.)**

Mine	Location	Date of start up	Initial annual capacity (tonnes)	Cost of facilities (\$ million)	Cost per ton of capacity (\$)
<b>Mine and mill projects<sup>a</sup></b>					
Silver Bell	Arizona, U.S.	1953	18,000	\$ 18	\$1,000
Tyrone	New Mexico, U.S.	1969	50,000	118	2,360
Andina	Chile	1970	58,000	139	2,400
Lornex	BC, Canada	1972	54,000	138	2,555
La Caridad	Mexico	1980	140,000	673	4,800
Copper Flat	New Mexico, U.S.	1982	18,000	103	5,720
Tintaya	Peru	1985	52,000	326	6,270
<b>Mine, mill, and smelter projects<sup>b</sup></b>					
Toquepala	Peru	1959	132,000	237	1,800
Cuajone	Peru	1976	162,000	726	4,480
Sar Cheshmeh	[Iran]	1982	145,000	1,400	9,655

<sup>a</sup> Capacities stated in tonnes of copper content of concentrates.

<sup>b</sup> Capacities stated in tonnes of copper content of blister.

SOURCE: Simon D. Strauss, *Trouble in the Third Kingdom* (London: Mining Journal Books, 1986).

tures raise the costs of transportation and labor, and decrease the facilities' effective capacity. Transportation is expensive, because of the long distances and sometimes poor infrastructure, Labor is costly, because of the pay premiums and extra amenities required to keep skilled laborers in such settings. Reliable capacity is decreased, because of the possible closure owing to heavy snows or flooding conditions. The Andina copper mine in Chile is in a region that has trouble with avalanches. Its mill is built underground to help prevent closures.

### Infrastructure

Operations located in remote areas incur high infrastructure costs. A mine may have to build (or pay for) its own transportation, utilities (electricity and water), communications, housing, schools, recreation, and medical services. Although there are costs to operating these services, the heaviest burden is the capital outlay prior to the startup of the facility.

Infrastructure is a semi-public good and governments often get involved in its planning and funding. This is at times controversial, because it may be unclear whether a producer has paid its full share of the costs or has received subsidies.

### Public Profile

Minerals facilities are of great importance to their local economies, and thus the subject of much local political attention. In addition, they sometimes receive a great deal of national attention, especially when they account for a large share of a country's gross domestic product (GDP), foreign exchange earnings, and employment. Copper accounts for large percentages of total export earnings in Zambia (80 to 86 percent), Zaire (20 to 58 percent), Chile (42 percent), Papua New Guinea (34 percent), and Peru (17 percent).<sup>19</sup>

The high profile of mines and processing facilities (and the infrastructure that supports them) make them natural focal points for labor disputes,

demonstrations, civil disobedience, and insurrectionist sabotage. Production has at times been disrupted in Peru and Chile due to protests against their governments. Zambian copper and cobalt production shut down in December 1986 when a sharp devaluation of the national currency and the removal of subsidies on cornmeal triggered unrest.<sup>20</sup> During the 1960s and 1970s, the high profile of minerals facilities made them the frequent target of expropriation in politically unstable countries (especially in less developed countries—LDCs) as governments moved to establish political autonomy and fund development programs.

### Worker Compensation

The mining industry historically has had a very active labor force due to the high concentration of workers and the often harsh working conditions. Most minerals facilities have been unionized at one time or another, and the labor disputes have at times been hostile.<sup>21</sup> Over the years, collective bargaining and demanding skill requirements have yielded high pay and benefits for mine workers relative to other skilled laborers. Though compensation differs greatly for miners throughout the world, they are usually among the highest paid workers in their respective regions. Miners, on average, are paid 65 percent more than their countrymen in the LDC copper producers (Chile, Peru, Mexico, the Philippines, Indonesia, and South Africa). In the developed countries, miners' wage premiums range from none (Japan) to 40 percent (United States).<sup>\*\*</sup> The high pay is an incentive to mine managers throughout the world to cut the labor input wherever possible, and reinforces the drift to more capital- and energy-intensive operations.

<sup>19</sup> "Unrest Disrupts Zambian Production," *Minerals and Materials* (Washington, DC: U.S. Department of the Interior, Bureau of Mines, December 1986/January 1987).

<sup>21</sup> The Bisbee Deportation is one of the more infamous examples.

In 1917, the Shattuck-Denn, Calumet and Arizona, and Copper Queen Consolidated Mining companies (Phelps Dodge) persuaded the sheriff of Bisbee, Arizona to force striking miners and their sympathizers out of their homes at gunpoint. Over 1,200 intransigent miners were placed in railroad boxcars and hauled out of the State.

<sup>22</sup> Estimate by Resource Strategies Inc., Exton, PA.

<sup>19</sup> International Monetary Fund (IMF), *International Financial Statistics*. Data for Zambia are 1984-86; Zaire are 1981-83 (latest published); and Chile, Papua New Guinea, and Peru are 1986.

## COSTS AND TECHNOLOGIES

Within the context of the overall cost structure described in the previous section, production technologies greatly affect the costs of individual producers. Costs vary among the traditional mining, milling, and smelting technologies, and also differ between the traditional and nontraditional production methods (i.e., leaching and SX-EW).

### Mining Methods

**Surface and underground mines, since they must compete, have roughly similar production costs per pound of recoverable copper. How-**

**ever, the makeup of the costs are quite different for these two mining methods.** On a gross tonnage basis, underground mines are much more costly than surface mines. Working underground requires special systems for ore and personnel transport, ventilation, power transmission, etc., which add greatly to the cost of production (see ch. 6). Moreover, underground miners are considered more skilled and thus are more highly paid than their surface counterparts. Surface miners' skills are similar to those of construction workers, so there is potentially a greater supply of these laborers.



*Photo credit: Manley-Prim Photography, Tucson, AZ*

Underground mine development and maintenance, including tunneling, rock support, ventilation, electrical systems, water control, and ore and personnel transport, add significantly to mining costs.

The average mining cost for underground mines (\$6.90/tonne of ore) is nearly twice as high as the average cost for surface mines (\$3.80/tonne),<sup>23</sup> Underground mines, therefore, must contain richer ores (either in copper or by-products) to counteract the extra costs. The average ore grade is 1.27 percent copper for underground ores versus 0.75 percent copper for surface ores.<sup>24</sup> About 60 percent of NSW production comes from open pit mines.

### Smelter Technologies

Reverberatory furnaces—accounting for approximately half of NSW smelting capacity—are the most widely used smelter technology. However, use varies greatly among the major copper-producing countries. In Chile and Peru, until very recently nearly all the capacity used reverberatory furnaces, whereas in Canada most operations use flash and continuous technologies and less than 20 percent of capacity is reverberatory.

<sup>23</sup>R.D. Rosenkrantz et al., *Copper Availability—Market Economy Countries*, Bureau of Mines Information Circular 8930 (Washington, DC: U.S. Government Printing Office, 1983).

<sup>24</sup>Ibid.

In terms of factor productivity, reverberatory furnaces are the poorest performers. On average, they use several times the labor of the most labor-efficient process (INCO). They consume larger quantities of fossil fuels than do other technologies, and use more electricity than all except the electric furnace. They also incur the largest charges for fluxes, refractories, and other supplies.

At a few reverberatory smelters, the combustion air is enriched with oxygen. This modification improves the factor productivity and reduces costs by 25 to 28 percent (see table 9-3). Oxygen technologies are especially advantageous to smelters that can obtain plenty of inexpensive hydroelectric power to run a tonnage *oxygen* plant,<sup>25</sup>

Electric furnaces, compared with conventional reverberatories, have higher labor productivity and substitute electricity for fossil fuels. Electricity use in electric furnaces is nearly double that of any of the other smelter technologies.

<sup>25</sup>UNIDO, *supra* note 17.

**Table 9-3.—Production Costs of Several Chilean Copper Smelters  
(\$ U.S./tonne of concentrate)**

Smelter furnace	Chuquicamata reverberatory with oxygen injection	El Teniente reverberatory with oxygen injection	El Salvador reverberatory
Installed capacity (tpy concentrates) . . . . .	1,000,000	800,000	265,000
Concentrate grade (percent copper) . . . . .	37.8	38.0	34.0
Direct costs:			
Variable costs:			
Fuels . . . . .	\$15.35	\$12.06	\$29.85
Oxygen . . . . .	3.34	2.76	—
Refractories . . . . .	1.83	1.67	0.37
Air . . . . .	2.17	1.17	0.30
Electric energy . . . . .	1.00	0.42	0.07
Others . . . . .	2.42	2.93	21.53
Total . . . . .	26.11	21.01	52.12
Fixed costs: . . . . .	9.92	14.41	4.65
Total direct costs . . . . .	36.03	35.42	56.77
Indirect costs . . . . .	14.93	17.51	13.95
Total cost:			
(\$/tonne of concentrate) . . . . .	\$50.96	\$52.93	\$70.72
(¢/lb of copper) . . . . .	6.11¢	6.32	9.43¢

SOURCE United Nations Industrial Development Organization (UNIDO), *Technological Alternatives for Copper, Lead, Zinc, and Tin in Developing Countries*, document ID/WG 470/5, 1987.

Flash furnaces (INCO and Outokumpu) and continuous processes (Noranda and Mitsubishi) are generally the most efficient smelter technologies. Together they account for almost 40 percent of Western world smelting capacity. Most new smelters use flash furnaces. The Outokumpu flash smelting process was selected by about two-thirds of the smelters constructed around the world since 1970, and is now considered the "conventional" smelting process.<sup>26</sup> Flash and continuous processes each require roughly the same amount of labor and electricity. Gas and oil use, however, are somewhat greater for the continuous processes,

Smelter pollution control costs vary according to emissions standards and the types of smelters used. Under stringent standards, the environmental costs for a flash furnace are those of building and operating the acid plant. Controlling pollution to the same extent at an older reverberatory smelter requires additional capital expenditures for retrofitting the furnace with offgas collection and concentration equipment (see ch. 8).<sup>27</sup> The economics of the acid plant hinge on the attractiveness of the sulfuric acid market. If the market is good and the acid can be sold, part of the cost of operating the equipment can be recovered. If, however, the acid must be disposed of (an added cost), the cost burden of the acid plant is more substantial. To avoid disposal charges, U.S. smelters have sometimes sold their acid at prices that just cover the cost of its freight to market. Some smelters use their acid for leaching operations. This recovers some, but not all, of the costs of producing the acid.

<sup>26</sup>Simon D. Strauss, "Copper," *Engineering and Mining Journal*, vol. 187, No. 3, March 1986, pp. 29-33.

<sup>27</sup>In the United States, all smelters have either made all the necessary capital expenditures or have shut down. Thus the costs of pollution control are primarily those of operating the acid plant.

## Leaching and Solvent Extraction-Electrowinning

Leaching and SX-EW have become an important alternative to conventional mining, milling, smelting, and refining. Leaching, though, is currently viable only for oxide ores and waste materials, not for sulfide and complex ores. Processing waste dump materials to refined copper by this method is estimated to cost 30 to 40¢/lb of recovered copper. These estimates do not cover the costs of mining, so they apply only to already-mined materials (such as wastes) and in situ ore in old mine workings.

In the short term, using leaching/SX-EW on waste dumps and old workings is tantamount to the discovery of new low-cost ores. Waste dumps are large, but they are limited and eventually will be exhausted. When this happens, leaching/SX-EW, whether practiced independently or in tandem with a conventional operation, will have to assume some of the cost of mining and will become more expensive. The cost allocation problems will be similar to those experienced with by-products.

In situ solution mining of virgin orebodies coupled with an SX-EW plant bypasses the conventional processing route entirely. The costs of this unproven technique are estimated to be 45 to 55 ¢/lb, including the capital expenses. Because of industry conservatism, in situ mining is not likely to be used on richer ore bodies amenable to open pit methods until the process is widely proven for leaner ores.

Leaching/SX-EW operations are attractive, because of their relatively low costs and short construction times—a few months instead of years. They also require little supervision and maintenance.<sup>28</sup> Although subject to the same economies of scale pressures encountered in conventional operations, leaching/SX-EW is viable at scales smaller than those necessary for open pit methods.

<sup>28</sup>UNIDO, *supra* note 17.

## COSTS OF MAJOR COPPER PRODUCERS, 1986

### Overview

Cost data on the copper industry are available from several sources. Table 9-4 shows production cost data compiled by two different organizations: Brook Hunt and Associates Ltd. (from the World Bank—BH:WB, and from the Canadian Department of Energy, Mines, & Resources—BH:EM&R) and the U.S. Bureau of Mines (BuMines).<sup>29</sup> Several caveats are in order regarding these data. First, the sources tabulate their data using dissimilar cost definitions and different mine coverage, so direct comparison among the data sets is difficult.<sup>30</sup> Second, these are average costs—albeit

<sup>29</sup>The data from the Canadian Department of Energy, Mines, & Resources (BH:EM&R) are actually modified Brook Hunt data.

<sup>30</sup>The two sets of Brook Hunt data are not directly comparable.

The data published by the World Bank (BH:WB) are based on a simple cost accounting method (see box 9-A). The data published by Canada's EM&R (B H: EM&R) are based on a combination of simple costing and allocated costing.

weighted averages—for the operations in each country. Considerable variability exists in the costs at individual mines and processing facilities.

Smelting/refining costs are attributed to the country in which the ore is mined. Thus, some countries are shown in this table and subsequent figures even though they have little smelting/refining capacity. Other countries, such as Japan, West Germany, and Belgium, that have considerable capacity are not shown because they have little mine production. The costs of smelting/refining are calculated from either 1) actual costs if a single company mines, mills, smelts, and refines the copper; or 2) the smelting and refining treatment charges if there is an arms-length transfer between the milling and smelting stages.

These data show that costs declined in most countries between the early and mid 1980s. The

**Table 9-4.—Production Costs for Major Non-Socialist Copper Producing Countries**  
(¢/lb refined copper, nominal \$U.S.)

Country	1975	1980	1984	1985	1981	1986	1981	1986
		BH:WB			BH:EM&R		BuMines	
PNG	23.8	17.9	32.4	43.2	NA	56.9	NA	29.6'
Indonesia	35.5	33.3	46.0	49.7	NA	40.6	NA	29.6'
Chile	47.2	56.7	48.8	42.2	70	44.7	44.6	29.9
Peru	51.1	41.2	56.8	41.2	68	62.2	57.8	36.6
Zaire	55.1	51.1	45.2	39.8	62	45.9	50.4	38.6
Zambia	61.6	84.3	66.0	55.8	84	48.6	67.6	40.5
Mexico	27.3	42.1	37.9	79.5	NA	85.9	49.3	44.9
Australia	38.3	27.6	63.8	51.9	79	42.0	NA	48.9
South Africa	41.3	42.7	45.6	28.6	NA	39.3	NA	49.1
United States	61.6	73.4	78.1	65.3	86	60.4	79.1	54.5
Canada	28.4	-9.6	56.1	42.3	68	57.0	49.5	55.9
Philippines	38.1	57.3	55.5	85.9	NA	78.1	67.8	69.6
Average	48.8	50.0	56.9	50.6	NA	NA	62.0	46.0

NA = not available.

aBureau of Mines cost data for PNG and Indonesia are combined to avoid disclosing individual company data

#### SOURCES:

BH:WB— Brook Hunt & Associates Ltd. data

Source: K. Takeuchi et al., *The World Copper Industry*, World Bank staff commodity working papers, no. 15, 1987.

Figures for South Africa cover Namibia also.

*Direct Costs* (mining, milling, smelting, and refining costs, including all freight costs to market, and marketing costs)

plus *Indirect Costs* (including corporate overhead, research and exploration, and extraordinary charges such as strike reserves, excluding income taxes) plus *Interest Expenses* (net of any interest receivable) on short-term loans, long-term loans, overdrafts, commercial paper, etc.

minus *Byproduct Revenues* (full credit for all properties)

BH:EM&R— Brook Hunt & Associates Ltd. data

Source: Canadian Energy, Mines, and Resources, Mineral Policy Sector, "Copper Cost League"

Figures for South Africa cover Namibia also.

*Direct Costs* (mining, milling, smelting, and refining costs, including all freight costs to market, and marketing costs)

plus *Indirect Costs* (including corporate overhead, research and exploration, and extraordinary charges such as strike reserves, excluding income taxes) plus *Interest Expenses* (net of any interest receivable) on short-term loans, long-term loans, overdrafts, Commercial paper, etc.

minus *Byproduct Revenues* (full credit for properties with over 65 percent of their revenue from copper, pro-rated allocation for properties for which copper provides between 30% and 65% of revenues)

BuMines— Bureau of Mines data

Source: K.E. Porter and Paul R. Thomas, "The International Competitiveness of United States Copper Production," to be published in *Minerals issues* — 1988, Bureau of Mines, U.S. Department of the Interior, 1988

Figures do not cover the operation at Bingham Canyon, USA (closed in 1986) or the nickel-copper operations of Inco and Falcon bridge, Canada

*Direct Costs* (mining, milling, smelting, and refining costs, excluding freight costs to market and marketing costs)

minus *Byproduct Revenues*

Does not include Interest, corporate overhead, depreciation, and taxes.



average cost of producing copper in Non-Socialist countries decreased 25 percent between 1981 and 1986 (BuMines). The BH:WB data show that costs fluctuate from year to year. Costs in 1980, for example, were somewhat lower than other years because of the high prices of most of copper's byproducts.<sup>31</sup> Despite their differences, the data sets agree that Chile, Zambia, and Zaire are lower-cost producers, and that Canada, the United States, and the Philippines are higher-cost producers. There seems to be some disagreement regarding South Africa, Australia, Peru, Papua New Guinea (PNG), Indonesia, and Mexico.

Figure 9-3 (BuMines data) shows the mining, milling, and smelting/refining costs and byproduct credits of the major producers as of January 1986.<sup>32</sup> Chile, PNG, and Indonesia had the lowest

<sup>31</sup>In 1980, gold was \$611.80/oz, silver was \$21.50/oz, lead was 54.5¢/lb, nickel was \$2.95/lb, and cobalt was \$25/lb.

<sup>32</sup>Gross operating costs, represented by the total length of the bar, are the sum of 1) mining, 2) milling, and 3) smelting/refining charges which include transportation costs (except for delivery of the refined products to the fabricating mills or other markets) for copper and byproducts. Net operating costs, depicted on the lower portion of the bar, equal the gross operating costs less the credits for byproducts.

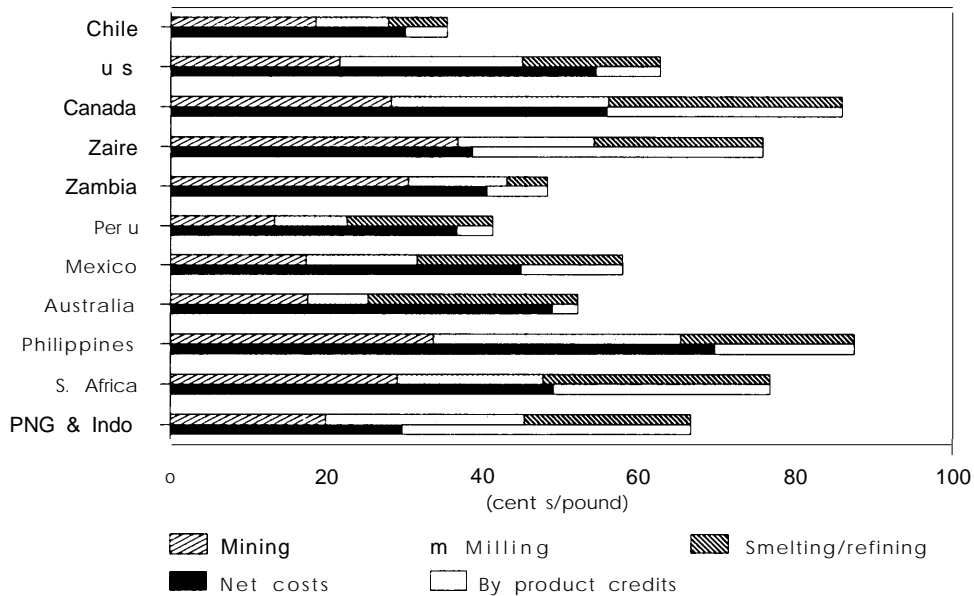
net operating costs, 30¢/lb.<sup>33</sup> Chile, however, is definitely the most important of these producers. It produced 1.39 million tonnes of copper compared with the 242 thousand tonnes (kt) combined production of PNG and Indonesia. Next lowest were Peru, Zaire, and Zambia with net operating costs ranging from 37 to 41¢/lb. Mexico, Australia, and South Africa, with net costs ranging from 45 to 49¢/lb, comprised the next tier of producers. The United States and Canada, with net costs of 55 and 56¢/lb respectively, were relatively high cost producers. The Philippines, with net operating costs of 70¢/lb, was the highest cost producer.

Figure 9-4 (BH:WB data) shows the direct costs, indirect costs, interest, and byproducts credits of the major producers in 1985.<sup>34</sup> In most countries,

<sup>33</sup>All country-specific ¢/lb figures are weighted average costs for that country's producers and are based on the amount of refined copper ultimately recovered from entire processing sequence. Bureau of Mines cost data for PNG and Indonesia are combined to avoid disclosing individual company data.

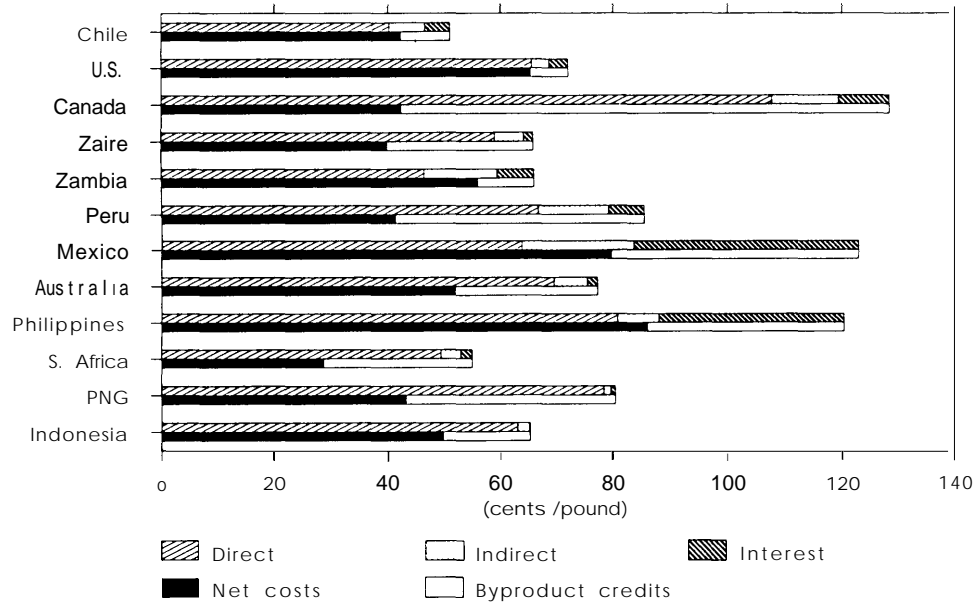
<sup>34</sup>Gross corporate costs, represented by the total length of the bar, are the sum of: 1) direct costs, 2) indirect costs, and 3) interest charges. Net operating costs, depicted on the lower portion of the bar, equal the gross operating costs less the credits for byproducts. See notes for table 9-4.

**Figure 9-3.-Operating Costs of Major Non-Socialist Copper Producers, 1986**



SOURCE: OTA from Bureau of Mines data, K.E. Porter and Paul R. Thomas, "The International Competitiveness of United States Copper Production," to be published in **Mineral Issues 1988** (Washington, DC: US. Department of the Interior, Bureau of Mines, 1986).

**Figure 9-4.-Corporate Costs of Major Non-Socialist Copper Producers, 1985**



SOURCE: OTA from Brook Hunt & Assoc. data, Kenji Takeuchi et al., *The World Copper Industry* (Washington, DC World Bank staff commodity working papers, No. 15, 1987).

interest expenses were less than 9\$/lb and less than 10 percent of gross cash costs. The exceptions were the Philippines and Mexico, where interest accounted for 32 and 39 C/lb, respectively. Indirect costs also contributed rather unevenly to production costs. These costs averaged 70/lb for all producers, but were considerably higher in Canada (120/lb), Peru (120/lb), Zambia (130/lb), and Mexico (200/lb).

### 1986 Producer Profiles

Table 9-5 summarizes the costs (BuMines data) and structural profiles of the major copper producers. Unless noted, all production and cost figures presented in this section are for 1986.

#### Chile

**Chile, with mine production of 1.39 million tonnes of copper in 1986, is the largest and most competitive copper producer in the world.** It achieves this position through low overall gross operating costs (35 C/lb), with low costs in each of the major production segments—mining

(19 C/lb), milling (9 C/lb), and smelting/refining (84/lb). It receives very little credit from by-products (50/lb), but its net operating costs are still low (30 C/lb). Mining is the major cost component in Chile, accounting for about half of gross operating costs.

About 80 percent of Chilean production comes from four mines run by the government-owned Corporation Nacional del Cobre de Chile (CODELCO): Chuquicamata (421 ktpy), El Teniente (293 ktpy), El Salvador (106 ktpy), and Andina (100 ktpy). Chuquicamata and El Teniente are the two largest copper mines in the world.<sup>35</sup> Another government-owned company, Empresa Nacional de Minería (ENAMI), operates a smelter and refinery to support small and medium-sized mines. The ENAMI smelter also processes surplus concentrates from the CODELCO mines.

Chile's operations are characterized by moderate ore grades (average 1.0 percent), low by-

<sup>35</sup>El Teniente is the world's largest underground mine of any mineral.

**Table 9-5.—Cost and Structural Profiles of Major Non-Socialist Copper Producing Countries**

	Chile	United States	Canada	Zaire	Zambia	Peru	Mexico	Australia	Philippines,	South Africa	PNG	Indonesia	Low (<)	High (≥)	
Net operating costs . . . . .	Low	Med	Med	Low	Med	Low	Med	Med	High	Med	Low <sup>a</sup>	Low	<sup>a</sup> 40	60	¢/lb
Gross operating costs . . . . .	Low	Med	High	High	Med	Low	Med	Med	High	High	Low <sup>a</sup>	Low	<sup>a</sup> 45	65	¢/lb
Byproducts . . . . .	Low	Low	High	High	Low	Low	Med	Low	Med	High	High <sup>a</sup>	High	<sup>a</sup> 10	20	¢/lb
Wage rates . . . . .	Med	High	High	Low	Low	Med	Low	High	Low	Low	Low	Low	6	12	\$/hour
Electricity rates . . . . .	Med	Med	Med	Low	Low	High	Med	Low	High	Low	High	Low	4	10	mils/Kwh
<b>Mining:</b>															
Overall cost . . . . .	Low	Med	Med	High	High	Low	Low	Low	High	Med	Low	Low	20	30	¢/lb
Feed grade . . . . .	Med	Low	Low	Very high	High	Med	Low	High	Low	Low	Med	Low	0.7	1.2	%Cu
Percent surface mining . . . . .	Low	High	Med	Low	b	High	All	None	Med	Med	All	High	60	60	%
<b>Milling:</b>															
overall cost . . . . .	Low	High	High	Med	Med	Low	Med	Low	High	Med	High	Low	10	20	¢/lb
Percent leaching . . . . .	Med	High	Low	None	High	Med	High	None	Low	Low	None	Low	20	40	0/0
<b>Smelting and refining:</b>															
Overall cost <sup>c</sup> . . . . .	Low	Med	High	High	Low	Med	High	High	High	High	High	High	10	20	¢/lb
Percent SX-EW (capacity) . . . . .	Low	High	Low	None	High	Low	Low	None	None	None	NA	NA	10	20	0/0
Percent flash or continuous.....	Low	Med	High	None	None	None	Med	None	All	Low	NA	NA	40	70	0/0

NA = not applicable.

<sup>a</sup>Bureau of Mines cost data for PNG and Indonesia are combined to avoid disclosing individual company data.

<sup>b</sup>All Zambia's mines are underground or combination underground/surface Operations.

<sup>c</sup>Calculated from either actual costs if a single company mines, mills, smelts, and refines the copper, or the smelting and refining treatment charges if there is an arms-length transfer between the milling and smelting stages.

SOURCE: Office of Technology Assessment, 1988.

products production, and a high proportion (about half) of underground mine capacity. **Competitiveness in Chile is based on the moderately rich ores and the sophisticated large-scale technologies. There is also a favorable investment climate, a well-developed mining infrastructure, and a low paid (\$1.60/hour) and highly skilled workforce.** These factors have attracted several large foreign investment minerals projects. Foreign companies have interests in projects at La Escondida and Cerro Colorado, and are conducting feasibility studies at Collahuasi.<sup>36</sup>

**Declining ore grades are a major challenge to Chile's long-term competitiveness.** Ore grades are falling faster in Chile than elsewhere in the world. The ore grade at Chuquicamata was 2.12 percent in 1980, but is projected to fall to between 1.0 and 1.35 percent by 2000. CODELCO has addressed this decline through capacity expansion and exploitation of oxide resources. The strategy has been to expand ore processing capacity enough to keep total refined copper output (and market share) constant or expanding. Central to this plan are the exploitation of oxide reserves from Mina Sur and the Chuquicamata pit, plus the leaching of waste dumps and low-grade sulfide ore stock.<sup>37</sup> The investment has been substantial; CODELCO reported that it spent \$2.4 billion for capital investments in the past decade. Its average production costs fell from 840/lb in 1974 to 41¢/lb in 1985, but rose slightly to 42¢/lb in 1986 because of decreases in ore grades.<sup>38</sup> Current investment plans to arrest the cost increases are expected to raise the capacity of Chuquicamata to 800 ktpy by the early 1990s.<sup>39</sup>

Chilean copper mines are located at high altitudes and the weather can be severe. The Andina milling operation is underground for avalanche protection.

Until recently, all Chilean smelters used conventional or oxygen-injection reverberatory fur-

naces. In 1986, CODELCO installed a flash furnace at Chuquicamata. Chile's high proportion of oxygen-based furnaces and less stringent environmental regulations give it smelting costs comparable to those in Japan and one-third those in the United States, Canada, and Europe.<sup>40</sup>

Chile has a vast reserve of oxide resources and a climate that tends to oxidize the wastes and tailings from sulfide operations. Thus leaching and SX-EW have great potential in Chile. Leaching operations produced approximately 90 kt in 1986; their capacity is expected to triple by 2000.

## United States

**The United States, with mine production of 1.15 million tonnes of copper in 1986, is the world's second largest producer.** Gross operating costs in the United States are moderate (63¢/lb), and evenly distributed among the three sectors—mining (22 C/lb), milling (244/lb), and smelting/refining (18-/lb). Net operating costs are also moderate (55 Q/lb), and byproducts credits are low (8\$/lb).

There are approximately 60 copper mines in production in the United States. An additional 20 to 30 mines produce copper as a byproduct of gold, lead, silver, or zinc, but account for only a small percentage of domestic production.<sup>41</sup> The 15 largest producing U.S. copper mines are shown in Table 9-6.

**U.S. copper production is characterized by a high proportion of surface mines (85 percent) and a low feed grade (average 0.5 percent). The number of surface mines, modern technology, and good management practice make U.S. mines and mills among the most productive in the world in terms of workhours per tonne of ore. However, much of this advantage is lost because of high labor rates and low ore grades.**<sup>42</sup>

<sup>40</sup>UNIDO, supra note 1 i'.

<sup>41</sup>Jolly and Edelstein, supra note 38.

<sup>42</sup>"The fact that the United States sometimes mined a lower average grade of ore than other countries was in a real sense a reflection of American technical proficiency rather than the poor quality of its deposits. U.S. firms were actually capable of mining a lower grade of ore and still making a return." U.S. Congress, Congressional Research Service (CRS), *The Competitiveness of American Metal Mining and Processing*, report to the Subcommittee on Oversight and Investigations of the House Committee on Energy and Commerce, Committee print 99-FF (Washington, DC: U.S. Government Printing Office, July 1986), pp. 143.

<sup>36</sup>P. Velasco, "The Mineral Industry of Chile," *Minerals Yearbook, Volume III, 1985* edition (Washington, DC: U.S. Department of the Interior, Bureau of Mines, 1987).

<sup>37</sup>Drexel, Burnham, Lambert, *Special Copper Report, December 1983*.

<sup>38</sup>Janice L. W. Jolly and Daniel Edelstein, "Copper," *Minerals Yearbook, Volume 1, 1986* edition (Washington, DC: U.S. Department of the Interior, Bureau of Mines, 1988).

<sup>39</sup>Takeuchi et al., supra note 16.

**Table 9-6.—Major U.S. Copper Mines: Ownership, Locations, and Capacities in 1986**

Company	Mine	State	Capacity
Phelps Dodge . . . . .	Morenci/Metcalf	Arizona	172 ktpy
	Chino	New Mexico	95
	Tyrone	New Mexico	92
Magma Copper . . . . .	San Manuel	Arizona	108
	Pinto Valley <sup>a</sup>	Arizona	64
BP Minerals . . . . .	Bingham Canyon	Utah	200 <sup>b</sup>
Cyprus Minerals . . . . .	Sierrita/Esperanza	Arizona	91
	Bagdad	Arizona	47
Asarco . . . . .	Ray	Arizona	74
	Mission Complex <sup>c</sup>	Arizona	36
	Troy	Montana	18
	Silver Bell	Arizona	21
Montana Resources . . . . .	Continental (Butte)	Montana	89
Copper Range . . . . .	White Pine	Michigan	51
Inspiration Resources . . . . .	Inspiration <sup>d</sup>	Arizona	33
Noranda . . . . .	Lakeshore <sup>e</sup>	Arizona	11

<sup>a</sup>Includes Pinto Valley and Miami.

<sup>b</sup>Capacity after expansion.

<sup>c</sup>Includes Mission, Eisenhower, Pima, and San Xavier.

<sup>d</sup>Includes Inspiration and Ox Hide. Acquired and renamed Miami by Cyprus Minerals in 1988.

<sup>e</sup>Acquired and renamed Casa Grande by Cyprus Minerals in 1987.

SOURCE: U.S. Bureau of Mines.

Although most operations produce at least some byproduct, with the exceptions of Sierrita/Esperanza (molybdenum concentrate and silver), Tyrone (silver), and Bingham Canyon (gold), revenues from byproducts are fairly low. This does not mean that byproducts are unimportant at U.S. operations. Copper mines account for most of the domestic primary production of rhenium, selenium, tellurium, platinum, palladium, and roughly one-quarter of the molybdenum and silver.

Smelting in the United States is characterized by stringent air pollution controls and, until very recently, an unattractive acid market. A few older reverberatory smelting furnaces still operate (e.g., El Paso and White Pine), and one major electric furnace (Inspiration—now Cyprus). The electric furnace has been among the most costly of the domestic smelters to operate because of high electricity rates. Flash furnaces are used at Hayden (Asarco), and Chino and Hidalgo (Phelps Dodge); another is being installed at San Manuel (Magma).

The costs of the stringent U.S. environmental regulations are controversial (see ch. 10). The bulk of air pollution compliance costs are the capital expenses of building an acid plant, plus those of either building a new smelter or retrofitting an older smelter with improved gas collection and

cleaning equipment. Domestic smelters have either already spent these monies or have shut down. So, except for the debt servicing expenses, the capital costs of environmental compliance will have little influence on future U.S. competitiveness. Figure 9-4 suggests that the interest portion of the debt expenses is low, and probably has a limited effect on competitiveness.

There also are operating costs associated with the pollution control equipment. Here the presence of an acid market is crucial. The acid market in the United States is mostly on the Gulf Coast. Because of high transportation costs, acid produced by copper smelters in the Southwest is not competitive with that produced from sulfur from Frasch mines, sour gas conditioning, and crude oil refining near the Gulf Coast. The formerly important California market has been lost to sulfur from local crude oil refining. Smelters must therefore dispose of the acid or find some other use for it.

**The local market for acid in the Southwest has improved recently.** Acid is being used to leach copper mine wastes and oxides and gold ores. The vast quantities of copper oxide deposits and waste dumps makes leaching especially attractive in this region. Compared with other world producers, a high percentage of U.S. production is from leach operations. Leaching copper sul-



Photo credit: Jenifer Robison

Sprinklers applying leach solution to mine waste dumps. Markets for sulfuric acid in the Southwest have improved significantly with increased leach production.

vide minerals is not currently economical, but may someday become so. In the United States, leach production is expected to grow, but not to supplant mining, milling, smelting, and refining as the primary production method.

Wage rates are another major factor in U.S. cost competitiveness. Table 9-7 shows that wages in the United States—about \$16/hr in 1985—are much higher than those in the other major producing countries. Wage rates in LDCs typically are less than \$2/hour. Wages in the United States have been curtailed somewhat in recent years through union recertification and contract concessions. After the union was broken at Phelps Dodge (the result of a strike in 1983), and other producers negotiated labor concessions (in the midst of the hard times in 1986), wages declined 20 to 25 percent. Several producers have negotiated wage rates that are below the average

union contract rate in order to reopen mines (e.g., Montana Resources and Copper Range).

### Canada

**Canada**, with mine production of 768 kt of copper in 1986, is the world's third largest producer. It has moderate net operating costs (56¢/lb), high gross operating costs (860/lb), and high by-product credits (30¢/lb). Mining costs (28¢/lb) are high because of low ore grades (0.5 percent) and the large share of underground production. The costs of milling (28¢/lb) and smelting/refining (30¢/lb) are high owing to the extra processing for the byproducts.

Copper is mined primarily from porphyry deposits in British Columbia (BC) and central Canada, and from massive sulfide deposits in eastern Canada. The porphyry deposits contain gold,

**Table 9-7.—Wage and Electricity Rates in the Copper Industry  
(nominal U.S. currency)**

Country	Wage rates (\$/hour)		Electricity rates (mils/kWh)	
	1980	1985	1981	1985
<b>Developed:</b>				
United States . . . . .	11.90	16.00 <sup>a</sup>	28.5	25.1
Canada . . . . .	9.60	11.70	8.1	9.2
Australia . . . . .	10.00	9.80	19.4	20.8
Japan . . . . .	5.30	6.40	66.6	48.0
<b>Less developed:</b>				
Mexico . . . . .	2.70	1.80	51.1	41.0
Chile . . . . .	2.70	1.60	21.0	15.6
Philippines . . . . .	1.90	1.50	56.6	43.8
Peru . . . . .	0.90	0.70	54.2	42.5
Zambia . . . . .	2.40	0.60	20.4	13.9

<sup>a</sup>U.S. wage rates declined 20-25 percent in 1986 as a result of union decertification and contract concessions.

SOURCE: Resource Strategies, inc. *Copper Industry Analysis*, November 1987.

silver, and molybdenum. The massive sulfide deposits contain nickel, gold, and silver, or lead and zinc. Canadian operations are often groups of small mines. The largest producers are the Kidd Creek Timmins operations in Ontario (130 ktpy), the Highland Valley operations in BC (130 ktpy), and Utah Mines' Island Copper in BC (62 ktpy).<sup>43</sup> A group of nickel-copper mines in the Sudbury district of Ontario operated by INCO (Copper Cliff operations) and Falconbridge (Sudbury operations) are also large copper producers.<sup>44</sup> Canadian copper output, consequently, reflects the pressures of the nickel market.

Even disregarding the large nickel operations, **Canadian copper mines generally produce large quantities of byproducts and rely heavily on the sales of these commodities to remain profitable.** The principal byproducts are: zinc and silver at Kidd Creek, molybdenum concentrates and silver at Lornex, gold at Bell, Island Copper, and Afton, and gold and zinc at Ruttan.

Canadian smelters use mostly flash (e.g., Copper Cliff), continuous (Timmins, Home), and electric furnaces (Falcon bridge). **Sulfur recovery at Canadian smelters averages 25-30 percent, compared with 90 percent at U.S. plants.** Timmins is considering plans to raise its SO<sub>2</sub> recovery from 40 to 70 percent. A small proportion of copper

production comes from SX-EW (the only operation opened in 1986 in BC with a capacity of 5 ktpy).

As with the other industrialized countries, Canada has high wage rates. At about \$12/hour, however, Canadian wage rates are lower than those in the United States,

### Zaire and Zambia

The Central African copper producers, Zaire and Zambia, are discussed together because they share many operating characteristics and problems. **Zaire**, with mine production of 563 kt of copper in 1986, is the fourth largest copper producer. It **has very low net costs (39¢/lb), high gross costs (76¢/lb), and very high byproduct credits (37¢/lb). The costs of mining (37¢/lb) are high, despite the very rich Zairean ores, because of the high proportion of underground production and the high stripping ratios at the surface mines.** The costs of milling (18¢/lb) and smelting/refining (22 C/lb) are high because of the extra processing for the byproducts (primarily cobalt). Zaire is the world's largest cobalt producer.

Zaire's principal mines, Dikuluwe/Mashamba (146 ktpy), Kov(139 ktpy), and Kamoto (97 ktpy), are run by the State-owned enterprise La Générale des Carrières et des Mines du Zaire (Gécamines). The ores are oxides or mixed oxide-sulfides (carbonate and silicate minerals) in strata-bound deposits. They average 4.1 percent copper and are the richest copper ores being mined

<sup>43</sup>Highland Valley was formed by a merger of Lornex Mining Corp. Ltd (Cominco), Valley Copper Mines Ltd., and Highmont Mining Corp.

<sup>44</sup>These mines are not included in the BuMines cost data; their economics are difficult to assess because copper is only a byproduct.

in the world. However, Zaire's gross operating costs are very high because of the large amount of underground production (about half of the country's capacity), the high stripping ratios at the surface mines (typically 7:1 or higher), and the lack of a local fossil fuel source (coal is imported from Zimbabwe). Net operating costs are kept low with the revenues from cobalt sales. These low costs are not expected to prompt capacity expansion in the near term, because the market prospects for cobalt are not bright. As

**Zambia**, with mine production of 450 kt of copper in 1986, is the fifth largest producer. It **has low net costs (41 Q/lb), low gross costs (484/lb), and low byproduct credits (8¢/lb). The costs of mining are very high (304/lb), because of the high proportion of underground production.** Milling costs are moderate (13¢/lb), and smelting/refining costs are low (54/lb), because of the low labor rates and inexpensive hydroelectric power.

The major mines in Zambia are Nchanga (207 ktpy), Mufilira (102 ktpy), and Nkana (58 ktpy). All Zambian copper mines are run by the 60 percent State-owned Zambia Consolidated Copper Mines Ltd. (ZCCM). The ores are sulfide minerals in strata-bound deposits. They are very rich in copper (averaging 2.0 percent), but not nearly so rich as those in Zaire. Nchanga and Nkana produce some cobalt, but on average Zambian mines receive little from byproduct sales. All Zambia's mines are underground or combination underground/surface operations. Stripping ratios at the open pit portions of the operations are very high, almost 14:1.<sup>45</sup> Zambia's developed ore reserves are declining quickly. They are expected to be depleted by early next century. Large undeveloped reserves exist, however. There is also an abundance of inexpensive electricity, but power outages are frequent.

**Copper production in Zaire and Zambia must deal with problems of remoteness. The regional market for copper is small, so most of it is exported. The distance from the mines to the seaports is great, and the transportation network**

**is cumbersome and unstable.** In Zaire, the only export route entirely within Zaire is the 1600 mile-long National Route. Starting in the Shaba Region in southeast Zaire, this route consists of sections of road, railroad, and the Kasai and Zaire Rivers to arrive at Matadi on the Atlantic Coast. The transfers among the different forms of transportation, and between the differing rail gauges, are time-consuming and costly. Zaire is seeking commitment from multilateral lenders and the U.S.S.R. to construct a railroad to parallel and replace the barge transport section between Ilebo and Kinshasa on the Kasai river.<sup>47</sup> Copper also can be exported by railroad through Tanzania, South Africa via Zambia, or—given peace—Angola. Negotiations were underway in 1984 to allow Zaire the use of the Mozambique port of Beira.<sup>48</sup> Besides the costs inherent in the great distances and cumbersome transfers, there are problems with the transportation system's reliability. The rebellion in Zaire's Katanga province in 1978 shut down the railroad.

Zambia's major copper transportation route is the Tazara Railroad to Dar es Salaam in Tanzania. Built in the 1970s with Chinese assistance, the railroad was intended to reduce black southern Africa's dependence on rail routes through South Africa. Equipment, track, and maintenance problems have given it a poor record of reliability. Rehabilitation assistance has come from China (in the form of an extended grace period on the loan) and several Western European nations. Problems at the port of Dar es Salaam also cause delays in shipments.<sup>49</sup>

**Zaire and Zambia also have been plagued with internal political strife, hard currency shortages, power outages, and the acute threat of Acquired Immune Deficiency Syndrome (AIDS).** These factors make it difficult to get and keep skilled expatriate personnel and to obtain spare parts for maintenance of the mining equipment. The cash-

<sup>45</sup>Takeuchi et al., supra note 16.

<sup>46</sup>Porter and Thomas, supra note 8.

<sup>47</sup>G. A. Morgan, "The Mineral Industry of Zaire," *Minerals Yearbook, Volume III*, 1986 edition (Washington, DC: U.S. Department of the Interior, Bureau of Mines, 1988).

<sup>48</sup>U.S. Congress, Office of Technology Assessment, *Strategic Materials: Technologies To Reduce U.S. Import Vulnerability*, OTA-ITE-248 (Washington, DC: U.S. Government Printing Office, May 1985).

<sup>49</sup>Ibid.



flow problems of Géecamines and Zaire have led mines to cut costs by deferring their stripping and drawing down the ore stockpiles. These measures cut costs for only a short time.

### Peru

Peru, with mine production of 397 kt of copper in 1986, is the sixth ranked copper producer. **Peru's mining profile is similar to Chile's, but its smelting/refining costs are considerably higher.** It has low net costs (37¢/lb), low gross costs (41¢/lb), and low byproduct credits (5¢/lb). Costs are low for mining (13¢/lb) and milling (9¢/lb), but high for smelting/refining (19¢/lb).

Peruvian production is dominated by the open pit operations at Cuajone (127 ktpy) and Toquepala (112 ktpy) in southern Peru. These mines opened in 1976 and 1960, respectively. Both are owned and operated by the Southern Peru Copper Corporation, which is owned by four U.S. companies—Asarco (52.31 percent), Phelps Dodge (16.25 percent), Newmont (10.74 percent), and Cerro (20.70 percent). There are also numerous smaller mines in Peru, many of which process complex silver/copper/lead/zinc ores and derive most of their revenue from silver.

About 90 percent of Peruvian capacity is surface mining. The average ore grade is about 0.80 percent copper, and revenues from byproducts are very low. Peruvian operations are not so efficient as those in Chile. They have lower wage rates (\$().70/hour), but higher electricity rates (42.5 mils/kWh). Mines in Peru, like those in Chile, have trouble with rapidly declining ore grade. This has been the basis for the expansion of the Cuajone mine in southern Peru. Japanese smelters have invested in Peruvian projects to obtain concentrates to feed their plants. **Peru's moratorium on paying foreign debt is likely to make foreign investors reluctant to supply capital for further expansion or modernization.**

### Mexico

**Mexico**, with mine production of 285 kt of copper in 1986, is the seventh ranked copper producer. Its **net operating costs (45¢/lb), gross operating costs (58¢/lb), and byproduct credits (130¢/lb) are all moderate.** The costs are low for

mining (17¢/lb) and milling (14¢/lb), but are high for smelting/refining (26¢/lb). Mexican wage rates (approximately \$1.80/hour) are much lower than those in the developed countries.

There are two major Mexican copper mines, one at La Caridad (174 ktpy) and the other at Cananea (151 ktpy). Mexicana del Cobre owns the former and Industrial Minera Mexico owns the latter. Both are open pit operations in the state of Sonora within 100 miles of the U.S. border. The mines have low feed grades (0.7 percent copper) and the ores contain moderate amounts of byproducts, gold at Cananea and molybdenum at La Caridad.

La Caridad's concentrates are processed at the Nacozari flash smelter. Cananea has its own reverberatory smelter. Mexico's comparatively less strict pollution control regulations, make these smelters less dependent than their U.S. counterparts on the acid market. The different pollution standards and the issues of transborder emissions have been the source of contention between Mexico and the United States (see ch. 10). As the result of a 1987 treaty between the two countries, an acid plant was installed at the Nacozari smelter.

The debt incurred for the development of La Caridad is a major contributor to Mexico's costs. In 1985, interest expenses at Mexican mines amounted to 39¢/lb, or 32 percent of gross direct and indirect costs (BH:WB data). Due to inefficient management and operations, neither Cananea nor La Caridad generates sufficient profits (and thus foreign exchange) to contribute to Mexico's burgeoning interest payments. As a result, the Mexican government is trying to sell both operations to private firms.

### Australia

**Australia**, with mine production of 239 kt of copper in 1986, ranked eighth among copper producers. It **has moderate net operating costs (49¢/lb), moderate gross operating costs (52¢/lb), and very low byproduct credits (3¢/lb).** The costs of mining (18¢/lb) and milling (8¢/lb) are both low, because of high grade deposits and efficient operations. The smelting/refining costs (27¢/lb), however, are quite high.

Australian copper production is dominated by the Mt. Isa mine in Queensland. Mt. Isa is a vast underground operation that accounts for about 85 percent of Australian capacity. It has very rich ore (3.3 percent Cu), but generates little by-product revenues.

### The Philippines

The Philippines, with mine production of 223 kt of copper in 1986, is the ninth ranked copper producer. With net operating costs of 700/lb, **the Philippines is the highest cost major producer.** Its gross operating costs (880/lb) and byproduct credits (180/lb) are also high. **The costs of mining (34¢/lb), milling (32¢/lb), and smelting/refining (22 Q/lb) are high because of low ore grades and high electricity rates. Mines in the Philippines also have a high debt burden;** interest payments amounted to 32¢/lb, about 27 percent of gross cash costs in 1985 (BH:WB data).

Philippine copper production is dominated by the Atlas mines—Lutopan (66 ktpy), Carmen (65 ktpy), and Biga (39 ktpy)—and the Sipalay mine (51 ktpy). Together these mines account for over 60 percent of the country's capacity. About two-thirds of the capacity is at surface mines. The feed grade is fairly low (0.47 percent Cu), but revenues from byproduct sales, primarily gold, are substantial.

The Philippines is a major exporter of copper concentrates (ranked fifth in 1986), but these shipments have declined greatly in recent years. In the early 1980s, nearly all of the Philippines' production of ores and concentrates was exported. Japan received about 70 percent of these shipments in 1982. The Philippines now smelts and refines about half of its concentrate production. Much of the remainder (approximately 80 percent in 1985) is shipped to Japan.<sup>50</sup> Nearly 90 ktpy of Philippine capacity was affected by temporary or permanent cutbacks in the early 1980s. In 1982 and 1983, the government introduced support schemes to prevent further cutbacks. This included the maintenance of a price floor (75¢/lb in 1982 and 76¢/lb in 1983) and loans of up to 50 percent of the value of the mine output.<sup>51</sup>

<sup>50</sup>WBMS Bureau of Metal Statistics (WBMS) data.

<sup>51</sup>Drexel, Burnham, Lambert, *Special Copper Report*, Dec. 1983.

### South Africa

South Africa, with mine production of 184 kt of copper in 1986, is the tenth ranked copper producer. **Production costs in South Africa resemble those of Canada.** It has moderate net operating costs (49¢/lb), high gross operating costs (77¢/lb), and high byproduct credits (28¢/lb). Mining (29¢/lb) and milling (19¢/lb) costs are moderate. Smelting/refining costs are high (29¢/lb), because the smelting of byproduct lead and zinc are included.

South Africa has fairly low ore grades (0.64 percent Cu). The major South African producer is the Palabora operation, a surface mine near the Mozambique border. Palabora is owned primarily by Rio Tinto Zinc (U. K.) and Newmont Mining Co. (U.S.), and accounts for about 80 percent of South Africa's total copper production. It also produces uranium and zirconium.

### Papua New Guinea (PNG) and Indonesia

Papua New Guinea, with mine production of 174 kt of copper in 1986, is the eleventh ranked copper producer. PNG began producing copper in the early 1970s. Its capacity was financed in part by the Japanese in order to feed their smelters. In 1985, over 40 percent of PNG's production of ores and concentrates was sent to Japan for processing.<sup>52</sup> Currently, the Bougainvillea mine produces all of the copper in PNG. It is a surface mine with an ore grade of about 0.4 percent and large amounts of gold and silver. Another mine, Ok Tedi, has just begun to produce copper. The extensive gold cap that overlaid the primary copper ore has been mined to repay the project's capital costs. Ok Tedi is owned by Amoco (U.S.), Broken Hill Proprietary (Australia), several West German firms, and the government of PNG. Its expected capacity is over 600 ktpy of concentrates, containing 200 ktpy copper.<sup>53</sup>

Indonesia, with mine production of 96 kt of copper in 1986, is the twelfth ranked copper producer. Indonesia began production in the 1970s.

<sup>52</sup>WBMS data.

<sup>53</sup>Helmut Lüdtké, "Ok Tedi—a new copper giant on the market," *Metal Bulletin Monthly*, Jan. 1987, pp.18-19.

The major property is the Ertsberg mine at Gunung Bijih in the province of Irian Jaya (the island shared with Papua New Guinea). It is 85 percent owned by Freeport Indonesia, a subsidiary of Freeport McMoran (U.S.). Ertsberg produces copper concentrates (233 kt in 1985), gold (76,000 oz), and silver (1.11 million oz).<sup>54</sup> Mining and milling costs are low, because of the high ore grade (2.0 percent Cu).<sup>55</sup> Approximately three-quarters of Indonesian concentrate production is exported to Japan.<sup>56</sup>

Together, PNG and Indonesia have low net operating costs (30¢/lb), high gross operating costs (67¢/lb), and very high byproduct credits (37¢/lb). Mining costs (20¢/lb) are low to moderate, but the milling (26¢/lb) and smelting/refining (21¢/lb) costs are high. PNG has the lower net operating costs, but the higher gross operating costs and byproduct credits.

### Other Smelting Countries— Japan and West Germany

**Japan** (ranked third in 1986) and **West Germany** (ranked eighth) are major copper smelting and refining countries. Both countries **built their industries in the 1960s, because of concerns about dependence on foreign supplies** in light of rising copper consumption early in the decade.<sup>58</sup> **They also wanted, as part of their economic development strategies, to capture the value added in raw materials processing. Official agencies such as the Export-Import Bank of Japan and the German Kreditanstalt für Wiederaufbau provided financial assistance to the growing domestic copper smelting/refining industries to secure overseas supplies of ores and concentrates. New** sources of ores and concentrates arose in the 1960s and early 1970s when the Japanese and German copper smelting com-

panies offered their long-term purchase contracts and attractive financing. The non-integrated facilities that were built under these programs, along with ascendance of State-owned operations, decreased the market power of the established multinational copper companies based in Europe and the United States.<sup>59</sup>

Japan's copper mining industry is very small, but its smelting/refining industry has been one of the three largest since 1970. To achieve this position Japan has had to import enormous quantities of concentrates.<sup>60</sup> In 1985, Japanese smelters imported 3 million tonnes of ores and concentrates (over 98 percent of their consumption). The major suppliers were Canada (27 percent), the United States (12 percent), Chile (11 percent), the Philippines (10 percent), Papua New Guinea (9 percent), Australia (8 percent), and Indonesia (8 percent). Approximately 60 percent of the copper concentrate traded in 1985 was shipped to Japan.<sup>61</sup>

In the 1980s, Japan has sought new joint projects to counter the tight concentrate markets and production cutbacks by traditional suppliers. These new ventures include projects in Colombia and Chile and equity positions in Morenci (Arizona) and Chino (New Mexico). The Sumitomo Metal Mining Association Inc. began shipping its 15 percent of Morenci's output to Japan in April 1986. In addition, Japan is expected to receive 300 ktpy of copper (in the form of concentrate) from the La Escondida project in Chile when it goes into production.<sup>62</sup>

Japanese smelters are clustered in four regions; near Okayama (west of Osaka); near Iwaki (north of Tokyo), near Niihama (north side of Shikoku Island), and near Oita (east side of Kyushu Island). Most, but not all Japanese smelter capacity is on the coast. This greatly facilitates the delivery of concentrates, and shipping copper and sulfuric

<sup>54</sup>J.C. Wu, "The Mineral Industry of Indonesia," *Minerals Yearbook, Volume III*, 1985 edition, (Washington, DC: U.S. Department of the Interior, Bureau of Mines, 1987).

<sup>55</sup>1987/1988 E&MJ *International Directory of Mining*.

<sup>56</sup>OTA estimate based on WBMS data.

<sup>57</sup>Bureau of Mines cost data for PNG and Indonesia are combined to avoid disclosing individual company data.

<sup>58</sup>Smelter production in Japan grew from 187 kt in 1960 to 1,000 kt in 1973 and declined to 951 kt in 1986. In West Germany the production rose from 62 kt in 1960 to 233 kt in 1973 to 246 kt in 1986.

<sup>59</sup>Takeuchi et al., *supra* note 16.

<sup>60</sup>The tariff structure in Japan (high for refined copper, but low for concentrates) allows Japanese smelters to outbid other smelting countries for feed concentrates, and has been the source of trade friction (see ch. 4).

<sup>61</sup>WBMS data.

<sup>62</sup>J.C. Wu, "The Mineral Industry of Japan," *Minerals Yearbook, Volume III 1985* edition (Washington, DC: U.S. Department of the Interior, Bureau of Mines, 1987).

acid to their markets. About 60 percent of Japanese capacity uses flash furnaces and most of the rest use reverberatory furnaces. Compared with their U.S. counterparts, Japanese smelters pay roughly half the wage rate (about \$6.40/hour), but double the electricity rate (48.0 mils/kWh).

The major West German smelter is in Hamburg. It is a flash furnace run by Norddeutsche Affinerie, A.G. (owned by Degussa, Metallgesellschaft AG, and The British Metal Corp.). In 1985, West German smelters imported 550 kt of ores and concentrates (over 99 percent of their consumption). The major sources were PNG (33 percent), Mexico (19 percent), Poland (12 percent), and Chile (11 percent). Approximately 10 percent

of the copper concentrate traded in 1985 was shipped to West Germany.<sup>63</sup>

### Other Refining Countries—Belgium

Belgium is a major copper refining country (ranked sixth in 1986). It imports nearly all its blister or anode copper. Almost one-half comes from Zaire—its former colony—representing 40 percent of Zaire's output in 1985. South Africa and Sweden each account for about 13 percent.<sup>64</sup>

<sup>63</sup>WBMS data.

<sup>64</sup>ibid.

## COST CHANGES IN THE EARLY 1980s<sup>65</sup>

**Copper traditionally has been a cyclical industry. Financial losses in hard times were endured, because they were outweighed by the profits earned when prices recovered. This outlook changed during the early 1980s.** Copper prices hovered near or below the average U.S. production costs for an extended period. Domestic operations, therefore, bore the brunt of the industry's operating losses, production cutbacks, and plant closures. This experience fostered a view of the industry as one in which prices were expected to stay flat—and low—for a long time. Those operations that were to survive would have to improve their operations to be profitable at the prevailing prices.<sup>66</sup>

**Copper producers in the United States embraced this survival mentality and enacted aggressive programs of asset restructuring, cost reduction, and efficiency improvement. Uneconomical mines and plants were modernized or closed permanently. High-cost producers in Canada and the Philippines undertook similar programs. These adjustments plus shifts in external factors (byproduct prices, exchange rates, and inflation rates) beyond the control of indi-**

**vidual companies significantly changed the comparative costs of producers in the early 1980s.**

The U.S. Bureau of Mines, in a recent study, examined the relative effects of: 1) expansions and contractions, 2) byproduct prices, 3) macroeconomic trends, and 4) "real" cost improvements on the industry's cost structure.<sup>67</sup> Costs for properties that produced in 1981 were compared with those that produced in 1986. For 1981, the study evaluated 144 operations (in 25 countries) which produced 5.9 million tonnes of refined copper. Between 1981 and 1986, 47 mines closed and 16 new mines opened.<sup>68</sup> The 113 operations (in 29 countries) evaluated for 1986 produced 5.8 million tonnes of copper. The properties evaluated for both 1981 and 1986 accounted for 76 percent of world and 88 percent of NSW copper production in those years.

**The industry's internal changes and the economy's external effects decreased the NSW average production cost by 26 percent (in nominal terms) between 1981 and 1986.**<sup>69</sup> Average production costs declined substantially in the United

<sup>65</sup>Much of the analysis in this section is drawn from Porter and Thomas, *supra* note 8.

<sup>66</sup>Takeuchi et al., *supra* note 16.

<sup>67</sup>Porter and Thomas, *supra* note 8.

<sup>68</sup>Four countries, Oman, Burma, Iran, and Brazil, that had not been producers prior to 1981, began production between 1981 and 1986.

<sup>69</sup>A "nominal" comparison is based on costs expressed in the U.S. of the years they were incurred.

States (30 percent), Chile (33 percent), Peru (36 percent), Zambia (40 percent), and Zaire (24 percent); fell slightly in Mexico (9 percent); and increased somewhat in Canada (12 percent) and the Philippines (3 percent). Comparative costs also shifted over this period (see figure 9-5). Peru, Zambia, and the United States moved down the production cost curve, and Canada moved up to the high-cost portion of the curve.

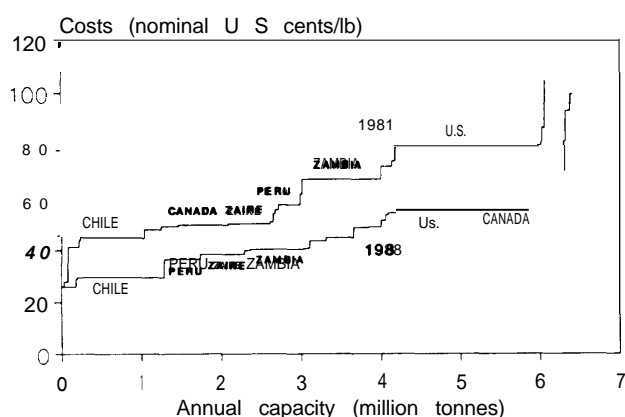
### Expansions and Contractions

Average costs declined and comparative costs shifted, to a certain extent, because of industry rationalization. **The closure of some high-cost producers and the expansion of low-cost operations probably more than offset the opening of some other higher-cost operations.**

The 47 operations (in the Bureau of Mines study) that closed had gross operating costs (in \$1981) 20 percent above those that continued producing. TO The United States had the largest

<sup>70</sup>Of the 47 operations that ceased production during the 1981-1986 period, 28 closed permanently due to exhaustion of reserves and 19 remain on a care and maintenance status. Those operations on care and maintenance are all in the United States, Canada, and the Philippines, countries in the upper quartile of the production cost curve for 1986 and have reduced production significantly since 1981.

**Figure 9-5.-Costs and Capacity of Non-Socialist Copper Production, 1981 & 1986**



SOURCE: OTA from Bureau of Mines data, K.E. Porter and Paul R. Thomas, "The International Competitiveness of United States Copper Production," to be published in *Mineral Issues 7988* (Washington, DC: U.S. Department of the Interior, Bureau of Mines, 1988).

production decline—25 percent from 1981 to 1986.

The 16 operations that opened have, on average, higher costs, especially at the milling, smelting, and refining stages. They have gross operating costs (in \$1 986) 32 percent above operations that have been producing since 1981. The new producers do not all have high costs. In the United States, Canada, and Peru, the new producers are lower-cost operations that accrue significant byproduct credits. In other countries, such as Brazil, India, Iran, and Oman, higher-cost operations opened for reasons other than economic competitiveness (e.g., self-sufficiency, employment, or foreign exchange earnings).

Expansion programs at existing operations helped lower the average production costs. Copper production increased in low-cost countries such as Chile, Mexico, and Peru.

### Byproduct Prices

**Shifts in byproduct prices greatly affected the comparative costs of copper producers in the early 1980s. The prices of most major copper byproducts declined between 20 and 50 percent from 1981 to 1986 (see table 9-8).** Only cobalt, which is important to the central African producers, increased in price. As of early 1988, gold, silver, lead, and zinc prices showed marked improvement relative to 1986.

Average byproduct credits in Chile, Mexico, Peru, the Philippines and the United States declined 2 to 4¢/lb of recovered copper, thereby offsetting some of the cost reduction measures instituted by producers in those countries. In Canada, with its high proportion of polymetallic deposits, byproduct credits declined by 15¢/lb over this period. In Zaire, the rise in cobalt price from \$5.00 to \$11.70/lb increased byproduct credits by 19¢/lb. However, most of this gain was lost when the cobalt price fell to the \$7.00/lb range in 1987.

### Macroeconomic Trends

Exchange rates and inflation rates, through their influence on the relative purchasing power of local currencies, have major effects on copper pro-

**Table 9-8.—Byproduct Prices (nominal \$U.S. per unit)**

Commodity	Units	January 1981	January 1986	January 1987	January 1988
Cobalt . . . . .	lb	5.00 <sup>a</sup>	11.70	7.00	7.50
Copper . . . . .	lb	0.89	0.69	0.64	1.31
Ferromolybdenum . . . . .	lb	4.60 <sup>a</sup>	3.65	3.93	4.05
Gold . . . . .	OZ	425.00	345.49	408.26	476.58
Lead . . . . .	lb	0.34	0.18	0.28	0.38
Moly conc . . . . .	lb	4.00 <sup>a</sup>	2.90	2.80	2.35
Silver . . . . .	oz	10.00	6.05	5.53	6.73
Zinc . . . . .	lb	0.41	0.33	0.41	0.44

<sup>a</sup>Estimated

SOURCE: Engineering and Mining Journal, various issues.

duction costs (see box 9-B). These macroeconomic factors also mask changes in "real" costs of producing copper. **Fluctuations in exchange rates and inflation rates helped rearrange the cost ranking of the copper producers in the early 1980s.** The comparative position of Chile, Mexico, Peru, Zaire, and Zambia improved from large devaluations of their national currencies relative to the U.S. dollar.

Between January 1981 to January 1987, macroeconomic shifts helped copper producers in Chile, but hurt those in the United States and Canada. Chile's real net operating costs declined by 4¢/lb, but its nominal costs fell by 23¢/lb.<sup>71</sup> U.S. producers reduced their real cost of producing copper by 50¢/lb, but their nominal costs decreased only 34¢/lb owing to the strength of the dollar. Canadian producers had an even larger share of their real cost reductions offset by a strong national currency. Real costs in Canada declined by 24¢/lb, but nominal costs dropped only 5¢/lb.

The purchasing power of the major copper producers' currencies (relative to 1980) is shown in figure 9-6 and table 9-9. Zambia and Zaire both had extreme devaluations of their currencies. Zambia's kwacha devalued from 0.87 per U.S. dollar in 1981 to 7.3 per dollar in 1986; Zaire's currency fell from 4.4 per dollar in 1981 to 60 per dollar in 1986. These large devaluations were partially, but not totally, offset by high rates of inflation.

<sup>71</sup>The "real" comparison is based on costs expressed in January 1981 \$U.S. The 1986 costs have been converted to January 1981 \$U.S. by removing the combined effect of Inflation differentials and exchange rate devaluation. The "nominal" comparison is based on costs expressed in the \$U.S. of the years they were incurred.

## Real Cost Improvements

**The real costs of producing copper declined in many countries in the early 1980s.** The preceding section cited Bureau of Mines data showing that, **from January 1981 to January 1987, gross operating costs dropped in the United States by 50¢/lb, in Canada by 24¢/lb, and in Chile by 4¢/lb.** These conclusions are supported by a World Bank study.<sup>72</sup> The World Bank converted the local portion of each country's direct and indirect production costs (BH :WB data) into constant dollars with the Relative Purchasing Power Index (RPPI, see box 9-B). The results are shown in table 9-10. From 1980 to 1985, real costs declined in the United States (33 percent), Canada (18 percent), Peru (16 percent), Mexico (15 percent), PNG (12 percent) and South Africa/Namibia (11 percent), but rose in Zaire (51 percent), Australia (29 percent), Indonesia (25 percent), and the Philippines (121 percent).

**Real costs have been reduced through productivity improvements and factor price cuts (primarily wage and benefit concessions).** From 1981 to 1986, the number of copper industry workers fell by 42 percent in the United States, 18 percent in Chile, and 20 percent in Canada. These reductions were due not only to plant closures and production cutbacks, but also efficiency improvements. Increased use of leaching and SX-EW techniques, computerized truck dispatching, in-pit crushing, automated processing controls, and other labor-reducing technologies have decreased the number of workers (and the amount of energy) needed to produce copper.

<sup>72</sup>Takeuchi et al., supra note 16.

### BOX 9-B.—Relative Purchasing Power of Currencies

The relative purchasing power of currencies change constantly as a result of inflation and fluctuating currency exchange rates. Because significant portions of the factors of production usually are purchased in local currencies, the relative costs of producing copper throughout the world are very sensitive to inflation rates and currency exchange rates. Any change in the relative price levels (i.e., inflation and deflation) that are not offset by currency devaluations or appreciation result in shifts in the relative costs among copper producers. For the relative purchasing powers of two currencies to stay constant, the exchange rate is expected to devalue in the direction of the country with the greater inflation. The balance of inflation and exchange rates is handled with the following Relative Purchasing Power Index (RPPI),

$$\begin{aligned} \text{RPPI (a:b)}_x &= \frac{\text{Inflation (b)}_{0 \text{ to } x}}{\text{Inflation (a)}_{0 \text{ to } x}} \times \frac{\text{Exchange Rate (a:b)}_x}{\text{Exchange Rate (a:b)}_0} \\ &= \frac{\text{prices (b)}_x / \text{Prices (b)}_0}{\text{Prices (a)}_x / \text{Prices (a)}_0} \times \frac{\text{Exchange Rate (a:b)}_x}{\text{Exchange Rate (a:b)}_0} \end{aligned}$$

where,

- RPPI (a:b)<sub>x</sub> = Relative Purchasing Power Index of currency A relative to currency B in year X. The change in the purchasing power of the currency of Country A relative to that of the currency of Country B from the base year to year X.
- Inflation (a)<sub>0 to x</sub> = Cumulative inflation in Country A, from the base year to year X
- Exchange Rate (a:b)<sub>x</sub>** = Exchange rate of the currency of Country A in terms of the currency of Country B, in year X
- Prices (a)<sub>x</sub> = General prices (e.g. Consumer Price index) in Country A in year X (assumes similar market baskets of goods and services in index calculations)
- Year O = Base year
- Year X = Index year

A RPPI of 1 means that the relative buying power of Country A's currency and Country B's currency is the same as it was in the base year. A RPPI greater than 1 means that the relative purchasing power of Country A's currency has increased. Thus, when production costs are denominated in a common currency, a RPPI greater than 1 indicates that Country A's costs have declined relative to those of Country B.

The Bingham Canyon Mine in Utah produced 223 kt of copper with 6,637 workers in 1981 (prior to the 1985-86 modernization), but is expected to produce 200 kt with 1,800 workers in 1988.<sup>73</sup>

Wage rates changed among the major producers during the 1981-86 period. Nominal wages were cut 17 percent in the United States and 36 percent in Chile, but rose by 12 percent in Canada. Phelps Dodge, which was paying a quarter of its production costs in the form of wages and benefits, led the U.S. industry's drive to lower wages and relax work rules.<sup>74</sup> In 1983, Phelps

<sup>73</sup>Bingham canyon was not included in the Bureau of Mines study because it was closed for much of 1986. However, it vividly depicts the cuts in labor that have occurred at all domestic mines.

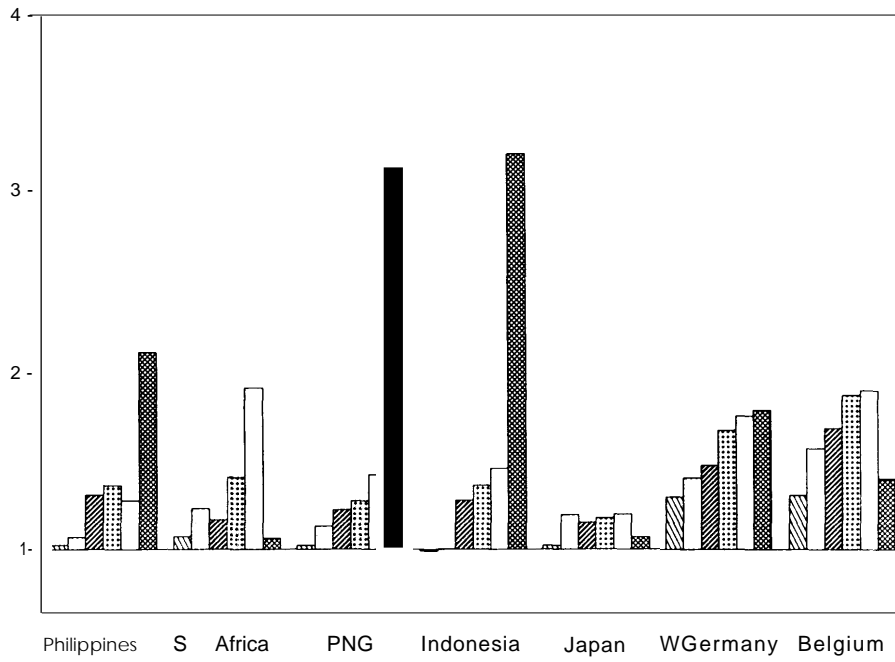
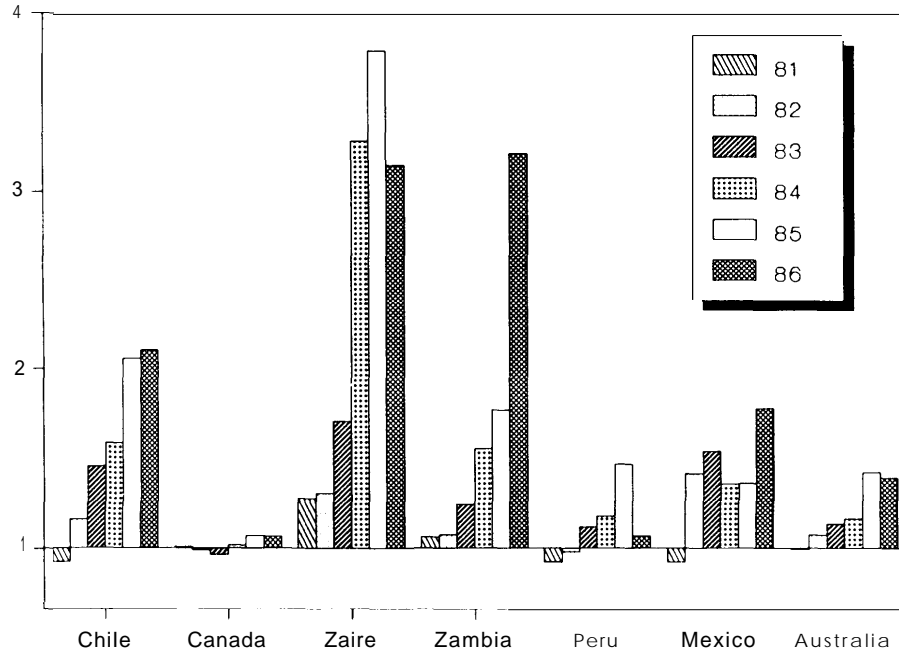
<sup>74</sup>CRU, Copper studies, February 1985.

Dodge produced despite a prolonged strike at its facilities. Workers at the company's Arizona mines (at that time Morenci and New Cornelia) and El Paso refinery voted against continued union representation in the fall of 1984.<sup>75</sup>

With the union decertified at Phelps Dodge and the market still down, the other major U.S. copper producers (Asarco, Cyprus, Kennecott, Inspiration, Copper Range, Montana Resources) won wage and benefit concessions of approximately 20 percent (5 to 8¢/lb) in 1986. When Cyprus Minerals acquired the unionized Sierrita Mine in 1986, it immediately fired all the workers and later rehired 200 of them without union contracts.

<sup>75</sup>The workers at the New Mexico operations, Tyrone and Chino (purchased from Kennecott in late 1986), still have a labor contract.

**Figure 9-6.-Purchasing Power of Currencies Relative to \$U.S., 1981-86 (Base Year 1980)**



SOURCE: OTA from IMF data.



Table 9-9.—Exchange Rates and Price Levels for Major Copper Producing Countries, 1980-87

	1980	1981	1982	1983	1984	1985	1986	1987
<b>Exchange Rates (currency par \$U.S.)</b>								
Chile . . . . .Peso	39.00	39.00	50.91	78.84	98.66	161.08	193.02	219.54
Canada . . . . .Dollar	1.17	1.20	1.23	1.23	1.30	1.37	1.39	1.33
Zaire . . . . .Zaire	2.80	4.38	5.75	12.89	36.13	49.87	59.63	112.40
Zambia . . . . .Kwacha	0.79	0.87	0.93	1.25	1.79	2.71	7.30	8.89
Peru . . . . .Inti	0.29	0.42	0.70	1.63	3.47	10.97	13.95	16.84
Mexico . . . . .Peso	22.95	24.51	56.40	120.09	167.83	256.87	611.77	1,378.18
Australia . . . . .Dollar	0.88	0.87	0.98	1.11	1.14	1.43	1.49	1.43
Philippines . . . . .Peso	7.51	7.90	8.54	11.11	16.70	18.61	20.39	20.57
South Africa . . . . .Rand	0.78	0.87	1.08	1.11	1.44	2.19	2.27	2.04
Papua New Guinea . . . . .Kina	0.67	0.67	0.74	0.83	0.89	1.00	0.97	0.91
Indonesia . . . . .Rupiah	627.00	631.80	661.40	909.30	1,025.90	1,110.60	1,282.60	1,643.80
Japan . . . . .Yen	226.74	220.54	249.08	237.51	237.52	238.54	168.52	144.64
West Germany . . . . .Mark	1.82	2.26	2.43	2.55	2.85	2.94	2.17	1.80
Belgium . . . . .Franc	29.24	37.13	45.69	51.13	57.78	59.38	44.67	37.33
<b>Consumer Price Indices (1980=100)</b>								
United States . . . . .	100.0	110.4	117.1	120.9	126.1	130.5	133.1	137.9
Chile . . . . .	100.0	119.7	131.6	167.5	200.7	262.3	313.4	375.7
Canada . . . . .	100.0	112.4	124.6	131.8	137.5	143.0	148.9	155.4
Zaire . . . . .	100.0	134.9	183.8	325.5	495.6	613.6	900.3	NA
Zambia . . . . .	100.0	114.0	128.2	153.4	184.1	253.0	383.6	NA
Peru . . . . .	100.0	175.0	288.0	609.0	1,280.0	3,372.0	5,999.0	1,1150.0
Mexico . . . . .	100.0	127.9	203.3	410.2	679.0	1,071.2	1,994.9	4,624.7
Australia . . . . .	100.0	110.0	122.0	134.0	140.0	149.0	162.0	176.0
Philippines . . . . .	100.0	113.1	124.6	137.1	206.2	253.8	255.7	265.4
South Africa . . . . .	100.0	115.2	132.2	148.4	165.7	192.6	228.5	265.3
Papua New Guinea . . . . .	100.0	108.1	114.0	123.0	132.2	137.1	144.6	NA
Indonesia . . . . .	100.0	112.2	122.9	137.4	151.7	158.9	168.2	183.8
Japan . . . . .	100.0	104.9	107.8	109.9	112.3	114.6	115.3	115.4
West Germany . . . . .	100.0	106.3	111.9	115.6	118.4	121.0	120.7	121.0
Belgium . . . . .	100.0	107.6	117.0	126.0	134.0	140.5	142.3	144.5

NA = not available.

SOURCE: International Monetary Fund, International *Financial Statistics*, vol. XLI, No.6, June 1988.Table 9.10.—Gross Corporate Costs of Major Copper Producers”  
(¢/lb at the 1980 relative Purchasing power of currencies)

	1975	1980	1984	1985
United States . . . . .	64.5	101.9	83.2	68.6
Chile . . . . .	56.5	76.3	74.7	78.2
Indonesia . . . . .	36.0	63.9	76.7	79.6
South Africa/Namibia . . . . .	51.5	94.6	99.6	83.9
Zambia . . . . .	63.8	89.4	92.3	87.1
PNG . . . . .	48.1	109.1	101.7	96.2
Mexico . . . . .	80.5	118.3	105.4	100.2
Australia . . . . .	49.3	77.9	118.7	100.6
Peru . . . . .	88.3	120.7	116.8	101.3
Philippines . . . . .	50.2	91.5	102.0	102.3
Canada . . . . .	101.1	152.9	171.8	126.0
Zaire . . . . .	94.4	113.0	151.3	171.1
Average . . . . .	69.7	103.9	107.1	NA

NA = not available.

\*Gross Costs include Direct Costs and indirect Costs, does not include interest Charges or Byproduct Credits

SOURCE: Kenji Takeuchi et al. The World Copper Industry, World Bank staff commodity working papers, No. 15 (Washington, DC: 1987/1975, 1980, and 1984. OTA estimate for 1985.

Cyprus employed a similar strategy at the other mines it bought since 1986. The labor cutbacks and compensation concessions have resulted in significant cost savings for U.S. copper producers.

**The productivity improvements and wage concessions of the 1980s probably will endure and improve the long-term competitiveness of the U.S. industry. Other measures, though, are likely to be more temporary.** Some producers deferred their repair and maintenance, overburden removal, and advance ore development-activities that delay costs rather than reduce them.<sup>76</sup> Stripping ratios in the United States, on average, declined by almost 0.8 tonnes of waste per tonne of ore from 1981 to 1986. Companies

<sup>76</sup>P.C.F. Crowson, "Aspects of Copper Supplies for the 1990s," paper presented at the Copper 87 Conference, Vina del Mar, Chile, Nov. 30 to Dec. 3, 1987.

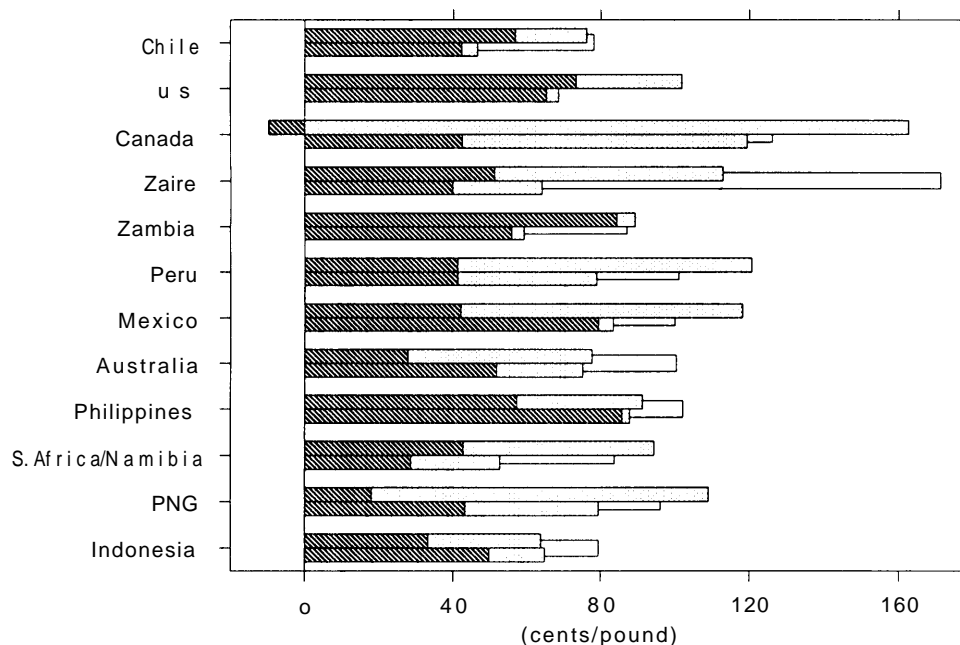
modified mine plans so that less expensive ore was extracted. Head grades were raised, which, unless coupled with dump leaching, cannot be practiced for long without ultimately diminishing a mine's level of reserves. Lastly, mines obtained lower smelting and refining treatment terms than can be expected in the future. The concentrate shortage that caused these favorable terms is ending and spot treatment charges are already rising. z'

## Summary

Figure 9-7 illustrates the effects on operating costs (BH:WB data) of the changes in real costs, byproduct credits, and currency purchasing power between 1980 and 1985. The figure shows

<sup>77</sup>1 bid.

**Figure 9-7.-Corporate Costs of Major Non-Socialist Copper Producers, 1980 & 1985**



**How To Read This Figure:** For each country, the bars in the foreground show the gross direct and indirect costs (total length of each bar), along with the byproducts credits and the resulting net costs. The top bar shows these data for 1980 (expressed in 1980 \$U.S.), and the bottom bar shows them for 1985 (in 1985 \$U.S.). The bar in the background shows what the gross direct and indirect costs would have been in 1985 had the relative purchasing powers of the various currencies held constant from 1980 to 1985 (i.e., 1985 costs in 1980 \$U.S.).

SOURCE: OTA from Brook Hunt & Assoc. data, Kenji Takeuchi et al., *The World Copper Industry* (Washington, DC: World Bank staff commodity working papers, No. 15, 1987).

that **external factors (byproduct prices, exchange rates, and inflation rates) were at least as important, if not more so, as real cost shifts in reshaping the competitive structure of the copper industry.** Nominal gross operating costs declined from 1980 to 1985 in all countries except Indonesia. The decline in nominal costs was due primarily to real cost cuts in Canada, Mexico, Peru, and PNG, and exchange rate movements

and inflation in the other countries. Real gross operating costs rose, in Chile, Zaire, the Philippines, Australia, and Indonesia. Byproduct credits declined for all producers. Nominal net operating costs rose in Canada, Mexico, the Philippines, PNG, Australia, and Indonesia, because the declines in nominal gross operating costs were not great enough to fully offset the losses in byproduct revenues.

## COST TRENDS AND OUTLOOK

### New Project Development

**Mines being developed, or considered for development, that will start production in the early 1990s may alter the comparative costs of current producers.** The most important and most closely watched are: La Escondida in Chile (300 ktpy), Neves-Corvo in Portugal (100 to 115 ktpy), Roxby Downs (Olympic Dam) in Australia (55 ktpy), and Salobo in Brazil (110 to 123 ktpy). In addition, the full impacts of copper production from the Ok Tedi mine (200 ktpy) and the newly modernized Bingham Canyon operation (200 ktpy) have not been felt.

### Real Cost Trends

**Ore grades are expected to keep declining quickly in Chile and Peru, because of the geology of the deposits and the swiftness with which they are being mined.** CODELCO'S average ore grade is projected to fall to between 1.0 and 1.35 percent by 2000. The strategy to expand production to combat this decline is expected to raise Chuquicamata's capacity to 800 ktpy by the early 1990s.<sup>78</sup> Large scale leaching and SX-EW operations are planned for Chile. Capacity is expected to rise to about 290 ktpy by 2000.

In Zambia, the problem is deposit exhaustion. All currently developed deposits are expected to be depleted by early next century. Significant reserves remain undeveloped. Obtaining the resources for their development may be difficult, however, given Zambia's economic problems.

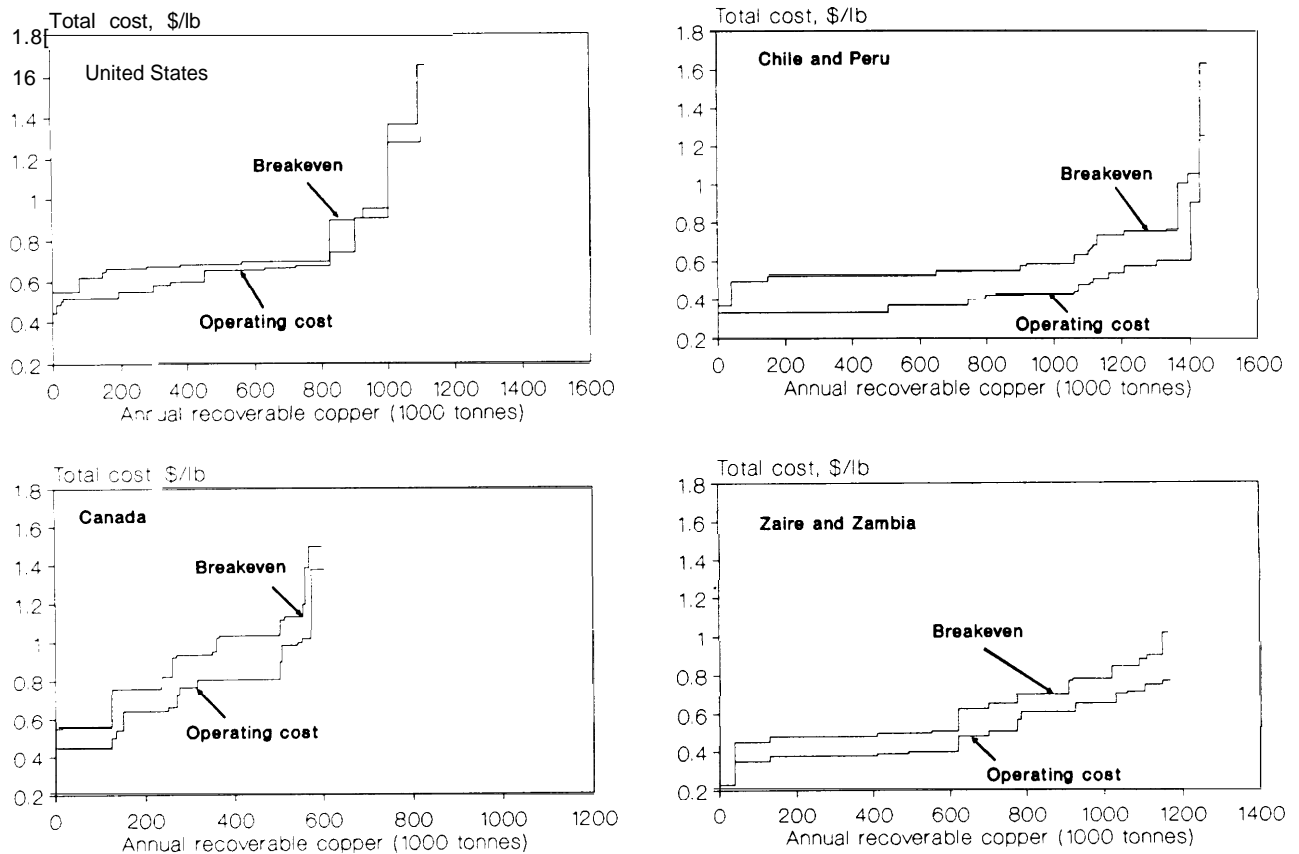
### Long Term Availability Costs

Forecasting the costs of future copper production is difficult. As the preceding section illustrated, external factors beyond the control of the copper companies can greatly influence costs. Byproduct prices and macroeconomic factors fluctuate tremendously and are impossible to predict with any certainty. The outlook for the real costs of production, however, is somewhat more stable.

The Bureau of Mines, through its Minerals Availability Program, compiles and evaluates data on deposits, mines, and plants that are being explored, developed, or produced worldwide. With these data, the Bureau estimates the long-term availability of many different mineral commodities, including copper, at different prices. These estimates are based on the anticipated cash flows for the productive lives of each deposit and facility. The cash flows embody information about known expansions, modernizations, ore grade depletion, etc. Using discounted cash flow techniques, the Program estimates the price necessary to keep each project in operation. This is the price a project needs to receive in order to cover its operating costs, depreciation expenses, and taxes, excluding those based on profit, over its lifetime. Cumulating these prices for all deposits and facilities yields a long-term availability cost curve (see figure 9-8). The costs developed under this system are not the costs for any particular year, but are the average costs that operations would see over their lifetime. However, the costs are denominated in a particular year's currency, so there is some benchmark for their magnitude.

<sup>78</sup>Takeuchi et al., Supra note 16.

**Figure 9-8.-Long-Term Costs and Capacity of Selected Producers (January 1985 \$U.S.)**



SOURCE: "Copper," *An Appraisal of Minerals Availability for 34 Commodities* (Washington, DC: Bureau of Mines, Bulletin 692, 1987).

Comparing the actual production costs of 1986 with these long-term availability costs (denominated in 1986 \$U. S.) gives an idea of where the Bureau of Mines thinks costs are headed (see table 9-1 1). Such a comparison does not tell what the costs will be, it just shows their general direction. It also assumes constant purchasing power of the currencies (i. e., constant exchange rates and no international differences in inflation).

**Table 9-11 suggests that production costs are expected to remain stable in the United States**

**and rise in most other major producers, with significant increases in Canada, Chile, and Peru. The United States is thus expected to become more competitive over the long-term. In any given year, however, the U.S. position may be significantly weaker or stronger than indicated by the long-term costs, depending on the prevailing byproduct prices and macroeconomic factors.**

Table 9-11.—Operating and Availability Costs for Major Copper Producing Countries. (¢/lb of refined copper, 1986 \$U.S.)

	Mining	Milling	Smelting/ refining	Gross operating costs	Byproduct credits	Net operating costs	Taxes	Capital recovery	Total availability costs
<b>PNG &amp; Indonesia:<sup>a</sup></b>									
1986 . . . . .	19.8	25.5	21.3	66.5	37.0	29.6			
Availability . . . . .	NA	NA	NA	NA	NA	NA	NA	NA	NA
<b>Chile:</b>									
<b>1986 . . . . .</b>	<b>18.5</b>	9.2	7.6	35.3	5.4	29.9			
<b>Availability . . . . .</b>	<b>29</b>	16	10	55	6	49	1	6	56
<b>Peru:</b>									
<b>1986 . . . . .</b>	<b>13.2</b>	9.3	18.7	41.2	4.6	36.6			
<b>Availability . . . . .</b>	<b>17</b>	18	25	60	5	55	1	12	68
<b>Zaire:</b>									
1986 . . . . .	36.7	17.5	21.5	75.7	37.1	38.6			
Availability . . . . .	37	18	22	77	40	37	8	7	52
<b>Zambia:</b>									
1986 . . . . .	30.3	12.7	5.3	48.3	7.8	40.5			
Availability . . . . .	31	14	5	50	9	41	7	12	61
<b>Mexico:</b>									
1986 . . . . .	17.2	14.3	26.4	57.9	13.0	44.9			
Availability . . . . .	NA	NA	NA	NA	NA	NA	NA	NA	NA
<b>Australia:</b>									
<b>1986 . . . . .</b>	<b>17.5</b>	7.7	27.0	52.2	3.3	48.9			
<b>Availability . . . . .</b>	<b>20</b>	11	33	64	6	58	1	7	66
<b>South Africa:</b>									
<b>1986 . . . . .</b>	<b>28.9</b>	18.8	29.0	76.7	27.6	49.1			
<b>Availability . . . . .</b>	<b>31</b>	24	27	82	11	71	—	13	85
<b>United States:</b>									
<b>1986 . . . . .</b>	<b>21.5</b>	23.5	17.7	62.7	8.2	54.5			
<b>Availability . . . . .</b>	<b>23</b>	21	19	63	9	54	2	11	67
<b>Canada:</b>									
<b>1986 . . . . .</b>	<b>28.1</b>	27.9	29.8	85.8	29.9	55.9			
<b>Availability . . . . .</b>	<b>26</b>	35	42	103	25	78	1	12	91
<b>Philippines:</b>									
<b>1986 . . . . .</b>	<b>33.6</b>	31.7	22.2	87.5	17.9	69.6			
<b>Availability . . . . .</b>	<b>36</b>	27	22	85	24	61	6	8	76

NA = not available.

<sup>a</sup>Cost data for PNG and Indonesia are combined to avoid disclosing individual company data.

SOURCE: 1986 data—K.E. Porter and Paul R. Thomas, "The International Competitiveness of United States Copper Production," to be published in Minerals Issues—1988 (Washington, DC: Bureau of Mines, U.S. Department of the Interior, 1988). Availability data—J. Jolly and D. Edelstein, "Copper," Minerals Yearbook, Volume I, 1986 edition (Washington, DC: U.S. Department of the Interior, Bureau of Mines, 1988).



Chapter 10

# Strategies for Future Competitiveness



# CONTENTS

	<i>Page</i>
<b>Measures of Competitiveness.....</b>	<b>221</b>
<b>Comparative Advantage.....</b>	<b>222</b>
<b>Market Share.....</b>	<b>223</b>
<b>Cost of Production.....</b>	<b>225</b>
<b>Profitability.....</b>	<b>225</b>
<b>Technology..... +.....</b>	<b>226</b>
<b>Staying Power.....</b>	<b>227</b>
<b>Federal Policies Affecting Competitiveness..... &lt;.....</b>	<b>228</b>
<b>Federal Tax Policy.....</b>	<b>229</b>
<b>Trade Policy.....</b>	<b>231</b>
<b>Defense Policies.....</b>	<b>235</b>
Environmental Regulation.....	237
Research and Development.....	242
Industrial Policy.....	244
<b>Industry Strategies Affecting Competitiveness.....</b>	<b>246</b>
Future Industry Options.....	248

## Boxes

<i>Box</i>	<i>Page</i>
<b>10-A, State and Local Assistance and Cost Concessions Obtained by Montana Resources and Copper Range.....</b>	<b>248</b>
<b>10-B, Cooperative Steel/Auto Industry Research.....</b>	<b>251</b>
<b>10-C, Forward Integration in the Aluminum Industry.....</b>	<b>252</b>

## Tables

<i>Table</i>	<i>Page</i>
<b>10-1. U.S. Market Share in the Copper industry: 1981-86.....</b>	<b>224</b>
<b>10-2. Mineral Income Tax Comparisons.....</b>	<b>230</b>
<b>10-3. other Federal Legislation Affecting Copper Operations.....</b>	<b>240</b>
<b>10-4. Federal R&amp;D Expenditures Related to Mineral Resources and Production.....</b>	<b>244</b>
<b>10-5. Strategies Adopted by U.S. Copper Companies in Response to Economic Conditions, 1980-87.....</b>	<b>247</b>
<b>10-6. 1986 R&amp;D Expenditures in Selected Industrial Sectors.....</b>	<b>248</b>

# Strategies for Future Competitiveness

---

The international competitiveness of firms and industries refers to the ability of companies in one country to produce and sell products in rivalry with those abroad. American industries and companies also compete among themselves for markets, profits, and resources such as investment capital and quality employees. How an industry will fare in international competition depends on factors ranging from technology, to governments' industrial policies, to the available natural, human, and financial resources.

Shifts in the international competitiveness of industries affect trade balances, foreign economic policy, and military security, and will determine quite directly the gross domestic product, and therefore the standard of living. The linkage between competitiveness and employment is much looser. By greatly improving their labor productivity, industries can rise in competitiveness while declining in employment.

In practice, the priorities of countries, industries, and firms vary and they use different measures of competitiveness. These, in turn, determine the government policies and industrial

management strategies used to maintain or increase an industry's competitive position. Thus, under adverse market conditions, a developing country that uses copper exports to finance imports and economic development may subsidize its copper industry directly. Developed countries tend to use indirect measures such as trade and tax policies to assist industries that are perceived to be disadvantaged due to foreign competition or market conditions.

Analyzing the competitiveness of the domestic copper industry is further compounded by the fact that copper is a fungible commodity. Once established standards have been meant (e.g., the purity of copper to be used for electrical purposes), there is little to distinguish copper produced in the United States from copper produced elsewhere other than its price, including shipping costs.

This chapter discusses the measures of competitiveness that may be applied to the copper industry. It then reviews legislative and industrial strategies that could help to maintain or improve the competitive position of the domestic industry.

## MEASURES OF COMPETITIVENESS'

**No single measure or statistical indicator is adequate to capture the complexity and dynamism of industrial competitiveness.** The full panoply of measures might include market share, profitability, cost of production, comparative advantage, ability to attract investment capital, technology and innovative potential, growth rate, capacity utilization, labor productivity, and/or closure costs. Which measures are considered the most important will depend on the firm's ownership and on national and corporate goals

<sup>1</sup>Much of the material in this section is drawn from previous OTA reports on industrial competitiveness, including *International Competitiveness in Electronics*, and *U.S. Industrial Competitiveness*. Other sources are referenced as appropriate.

and priorities. Where making money is the top priority, then short-term concerns will focus on production costs, profitability, market share, and labor productivity compared to other companies making similar products. If the primary goal is to maintain an industry because its products are important to national security or the economy, then the near-term concerns are more likely to be market share, capacity utilization, and staying power in the marketplace (based on avoidable costs), regardless of profitability. To remain competitive in the long term, however, all industries *must be* concerned about comparative advantage, growth and innovative potential, and the ability to attract investment capital.



## Comparative Advantage

International competitiveness is related to what economists term the global structure of comparative advantage: countries tend to export goods in which they are advantaged and import others. Export earnings are used to finance imports. Nations with the lowest average unit costs are likely to be major exporters.<sup>2</sup> Within this context, however, one must distinguish competition between U.S. firms and those in industrialized countries, versus those in less developed countries (LDCs).

**The potential sources of advantage within the world copper industry include resources, labor, capital, markets, and technological capabilities.** The domestic industry is both advantaged and disadvantaged in its resource base. On one hand,

<sup>2</sup>Gary L. Guenther, "Industrial Competitiveness: Definitions, Measures, and Key Determinants," Congressional Research Service, Feb. 3, 1986.

we have 17 percent of the world's demonstrated resources of recoverable copper—more than any other single country except Chile. Our porphyry ores are suited to large-scale, open-pit mining with relatively low stripping ratios. We also have large oxide deposits, which can be extracted with in situ leaching technology. On the other hand, our sulfide ores are relatively low-grade, which leads to higher production costs due to the expense in handling more material to produce an equivalent amount of copper (see ch. 5).

For porphyry deposits—the majority of world copper resources—this difference in grade will average out over time. For example, ongoing modifications at the Chuquicamata mine/mill in Chile are primarily to accommodate lower ore grades. In 15 years, American mines will still be working approximately the same grade ore they are today, but Chuquicamata's ore grade will have declined more than 50 percent.



S g ry m m g

In newly-industrializing economies, workers often are available in large numbers at low wage rates. This can provide a production cost advantage. The trade-off for industrialized economies is high labor productivity. Domestic copper labor productivity is excellent, and has improved markedly during the 1980s (see ch. 3). Wage reductions in 1986 plus continuing productivity gains have improved our cost competitive situation, but labor is still a much higher percentage of the U.S. production cost than for most foreign competitors (see ch. 9).

Large markets allowing economies of scale in production and lower transportation costs can be a source of comparative advantage. In the copper industry, however, this is largely negated by the extensive international trade. Moreover, as the less developed countries (LDCs) become more industrialized, their domestic markets for copper will expand.

Access to investment capital is another potential source of comparative advantage. Nongovernmental firms in industrialized countries typically raise capital through loans or sales of equity shares (stock). Cross-subsidization also can occur within a firm to the extent that profits from one product or division can be used to help another division over temporary hard times; this is one advantage of diversification. Government-owned copper operations rely more heavily on debt financing, often through international banking organizations (e. g., the Multinational Development Banks). As LDC debt multiplies, however, such loans will become more difficult to obtain (see ch. 3).

Finally, technological capabilities can be a source of comparative advantage. These include the employee skills as well as research and development (R&D) investments. While the United States has some advantage over less industrialized countries in this area, this often is negated by the speed of technology transfer (see below).

Although comparative advantage theory is a useful starting point for understanding the resource economics of international competitiveness, it overlooks other important trends. For example, shifting trade patterns are inevitable as third world countries become more developed. Yet it is difficult for mature markets to accommo-

date both established domestic producers and the development objectives of new market entrants, or to make the transition for domestic companies less painful. Economically, the problem is ascertaining the net gains from trade (e.g., to fabricators and consumers) after deducting adjustment costs for producers. Politically, the problem becomes one of determining how these net benefits shall be distributed both within a single economy and between it and its trading partners. j

An additional question is whether government policy, over time, can influence comparative resource advantages. Such policies might include worker training, funding for R&D related to unique resource endowments, or facilitating access to capital (e.g., through tax incentives).

### Market Share

International competitiveness defined in terms of market share is the definition given at the beginning of this chapter—the ability of firms in one country to design, develop, manufacture, and market their products in rivalry with firms and industries in other countries. **Market share may refer to a country's portion of total world production or shipments, it may mean net exports (value of exports less imports), or it may describe the fraction of the domestic market that is met by domestic production.** A major shortcoming of this measure is that losses in market share for heavily industrialized countries are inevitable as other nations progress economically.

American copper companies dominated the world market until the late 1960s. Then came a wave of nationalizations in Latin America and Africa. Where foreign governments did not completely take over, they exerted greater influence on operating patterns. Government ownership and control of foreign operations meant not only a loss of assets, but also a loss of market power. American companies no longer could regulate foreign production during times of reduced demand. Companies that lost foreign properties also were no longer able to use low-cost overseas pro-

<sup>3</sup>John Zysman and Laura Tyson (eds. ), *American Industry in International Competition: Government Policies and Corporate Strategies* (Ithaca, NY: Cornell University Press, 1983).

duction to offset curtailed output at higher-cost domestic mines when prices were low<sup>a</sup>

Table 10-1 compares U.S. market share in 1981 and 1986. **Our share of world mine production declined 6 percentage points from 1981 to 1986, and the share of primary smelter output and refinery production dropped 8 points and 3 points, respectively. In contrast, U.S. copper demand as a percent of Western world consumption remained constant. The difference between production and consumption shows clearly in the increase in U.S. net import reliance from 6 percent in 1981 to 27 percent in 1986.** It should be noted, however, that the period 1981-1986 was extraordinary. 1980 and 1981 were years of record consumption and production; they were followed by the recessionary conditions of 1982-

<sup>a</sup>U. S. Industry Responds to Dramatic Changes in World Role, " *CRU Copper Studies*, vol. 14, No. 4, Oct. 1986.

**Table 10-1.—U.S. Market Share in the Copper Industry: 1981.86 (1,000 metric tonnes)**

Measure	1981		1986		% change
	Tons	% of total	Tons	% of total	
<b>Mine production:</b>					
United States	1,538	23%	1,147	17%	-25%
World <sup>a</sup>	6,489	100	6,629	100	2
<b>Primary smelter production:</b>					
United States	1,317	21	908	13	-31
World <sup>a</sup>	6,059	100	6,828	100	12
<b>Primary refinery production:</b>					
United States	1,227	19	1,073	16	-13
World <sup>a</sup>	6,327	100	6,348	100	<1
<b>Refined consumption:</b>					
United States	2,030	27	2,122	27	5
World <sup>a</sup>	7,252	100	7,672	100	6
<b>U.S. imports for consumption:</b>					
Ore and concentrate	39		4		-89
Refined	331	16 <sup>c</sup>	502	24	51
Unmanufactured <sup>d</sup>	438		598		36
<b>U.S. exports:</b>					
Ore and concentrate	151		174		15
Refined	24		12		-50
Unmanufactured <sup>d</sup> NA			442		
U.S. net import reliance	(%) 6		27		350

<sup>a</sup>Market economy countries

<sup>b</sup>Copper content.

<sup>c</sup>Percent of U.S. refined consumption.

<sup>d</sup>Includes copper content of alloy scrap.

<sup>e</sup>As a percent of apparent consumption; defined as imports - exports + adjustments for Government and industry stock changes.

SOURCE: OTA from Bureau of Mines and World Bureau of Metal Statistics data,

84 and a gradual recovery thereafter. The recovery is expected to continue for mining; the U.S. Bureau of Mines projects 1988 domestic mine production at around 1.45 million tonnes—only 6 percent lower than in 1981.<sup>5</sup>

Although the United States has become a net importer of refined products, we continue to be a net exporter of copper concentrates. Domestic mine capacity utilization is relatively high for those mines considered to be economic properties in the current market (81 percent for mines operating in 1986). It is unlikely that the domestic industry could supply a much larger share of the market without reopening mines that have been closed for most of this decade or developing new capacity.

Smelter output dropped so much during this period due more to the permanent closure of facilities for environmental reasons than to economic conditions. Further major declines in domestic smelter capacity are unlikely (unless stricter emissions limitations are imposed), although smelter production is likely to fluctuate with market conditions. Indeed, domestic smelter capacity may increase with the addition of one new smelter, but it probably will be built by a Japanese firm. Thus it will contribute to domestic market share and employment, but not the market share or income of U.S. firms (unless they supply the concentrates).

The fraction of domestic consumption accounted for by imports reflects domestic versus foreign production costs (see below), as well as government policies (e. g., export subsidies), corporate strategies (closing mines, foregoing markets), and other factors. Export subsidies by LDCs are likely to continue. If the relative growth rates in U.S. and world copper consumption over the last 15 years continue over the next 15, with slow growth in U.S. mine capacity but more rapid growth in solvent extraction/electrowinning, U.S. refined production will continue to be about half of domestic consumption.

<sup>5</sup>Personal communication to OTA from Daniel Edelstein, U.S. Bureau of Mines.

## Cost of Production

Market share is only indirectly related to the competitiveness of individual firms, which are more likely to be concerned with production costs. Gross costs are determined by wage rates and labor productivity; the cost of materials, equipment, transportation, and energy; and the design of both products and manufacturing processes. Net costs also account for byproduct credits.

Generalizations about production costs are possible, but tend to be disproved by site-specific factors. For labor-intensive technologies such as underground mining with conventional smelting, developing countries with an abundance of inexpensive labor normally would be expected to be the low-cost producers. Yet Canada, with around 75 percent of its output from underground mines, has high gross costs but low net costs because of their advantageous byproduct credits. Moreover, despite the advantage gained from abundant human resources, developing countries still can benefit from technologies that are not labor intensive if they offer low capital costs and ease of operation (see discussion of technology transfer, below).

**In 1986, estimated average net operating costs in the United States were 54 cents/lb.** The average producer price for that year was 66 cents/lb. **Worldwide, the average net operating cost for the top 12 producing countries was around 44 cents/lb.** The range of costs in 1986 was estimated to be as low as 26 cents/lb and 30 cents/lb for Papua New Guinea/Indonesia and Chile, and as high as 70 cents/lb in the Philippines (see ch. 9).<sup>6</sup>

**The United States is most competitive in refining, with average costs comparable to those of the rest of the world.** Because refining is only around 7-8 percent of the total cost of production, however, it provides little leverage in overall competitiveness. Domestic mining and milling costs were high, averaging 75 percent of the operating cost, primarily because of low domes-

tic ore grades with only moderate byproduct credits and high labor costs.

Although smelting accounts for only 17 percent of domestic operating costs, **the United States had the highest smelting costs of all the major producing countries in 1986** due to labor costs and the additional cost of acid production for environmental control (currently around 87 percent sulfur dioxide removal). Adding an acid plant to the production line increases operating costs without necessarily providing a byproduct credit. Furthermore, capital costs of acid plant construction are high. Copper smelters in Canada, Chile, Mexico, Peru, Zaire, and Zambia—our major foreign competitors—are not faced with similar environmental regulations (see below). T

## Profitability

The profitability of an operation or firm is its real net income. **Profitability is largely determined by the difference between the cost of production and the price at which the product is sold.** Other factors can affect profitability, however. For instance, in Mexico, copper is traded in U.S. dollars, but profits are measured in pesos. Shifts in the exchange rate affect the amount of profit at a given price. In recent years, exchange rates in market economy countries have been free to adjust to prevailing market conditions. One consequence of more flexible exchange rates is that domestic industries may be competitive at one time but not another solely because of exchange rate shifts.

For a nongovernmental corporation, profitability directly determines whether a company or facility will continue to operate, and for how long. Profitability controls the ability to obtain debt and to attract equity investors. It also determines the amount of money available for maintenance and capital improvements. Government-owned operations in developing countries are concerned more with generating foreign exchange than with

<sup>6</sup>Janice L. w. Jolly and Daniel Edelstein, "copper," preprint 'rem 1986 *Bureau of Mines Minerals Yearbook* (Washington, DC: U.S. Department of the Interior, 1987).

<sup>7</sup>Lawrence J. McDonnell, "Government Mandated Costs: The Regulatory Burden of Environmental, Health, and Safety Standards of U.S. Metals Production," paper prepared for the conference Public Policy and the Competitiveness of the U.S. and Canadian Metals Production, Golden, CO, January 1987.

profitability, and can sustain operating losses for a longer period.

Domestic copper companies lost a lot of money during the depressed conditions of the early 1980s. Amoco Minerals lost nearly \$60 million on copper from 1981 to 1985, when they spun off their copper properties to Cyprus Minerals; Phelps Dodge lost **\$400 million** between 1982 and 1984; and Kennecott lost over \$600 million between 1982 and 1985. Anaconda—for decades the giant of the world mineral industry—went out of business. This situation began to change in 1985, and has continued to improve since, as costs declined while demand and prices increased. **All the major domestic companies except Magma had a positive net income in 1987, and Magma expects to be profitable when their smelter furnace replacement is complete.**

### Technology

The definitions of competitiveness discussed above are based on either market or resource economics. Other definitions are technology-based, and refer to superior product and process technology. The types of definitions are not necessarily unrelated—superior process technology is one way to achieve low costs; superior products are one way to increase market share.

The role of technology is less important in determining competitiveness in the copper industry than in, say, electronics, for two reasons. First, technology transfer among companies and countries is rapid. Second, copper is a fungible commodity with well-established standards for purity, so distinguishing among companies' products is difficult.

**Technology transfer is the interchange of technological innovations among companies and countries.** When one company or country develops a new process that either reduces costs, improves productivity, or exploits new resources, it enjoys a competitive advantage as long as the innovation remains secret or is protected by patents. The innovation is then transferred to other countries or companies through licenses under the patent, and the licensee pays royalties. Over time, incremental changes remove even patent

protection, and the innovation is adopted universally where it can bestow some benefit. This process may occur quickly, or it may take years.

**In the copper industry, technology transfer is almost instantaneous.** This occurs for several reasons. First, most major technological advances in copper mining and processing are developed and introduced by equipment vendors rather than copper producers. The vendors have a financial interest in seeing rapid and widespread adoption of their innovations. The value of this trade by domestic vendors is important for our balance of payments. Exports accounted for around 33 percent of U.S. mining and mineral processing machinery shipments in 1982, while imports were only 7 percent of domestic consumption. While other countries are beginning to make inroads on world market share in mining and processing machinery, the United States remains a net exporter in this area. B

In contrast, modern smelting furnaces and the latest advances in electrowinning (the Mt. Isa process) were developed in other countries. Yet American copper producers also benefit economically from the productivity gains and cost reductions brought by foreign technological advances.

Other innovations are adapted from other metals sectors. For example, the earliest concentration techniques were developed based on methods used on gold ore. The solvent extraction/electrowinning (SX/EW) process originated with uranium processing. Moreover, because each ore body is unique, copper companies typically need to engineer an innovation to suit their own situation. These multiple, incremental changes largely negate the purposes of patents.

Finally, porphyry ore bodies—which have been the focus of copper exploration and development for much of this century—are very similar all over the world. Their similarities have helped to standardize mining and metallurgical strategies for their exploitation, and thus facilitate rapid technology transfer.

<sup>81</sup> International Trade Administration (ITA), *A Competitive Assessment of the U.S. Mining Machinery Industry* (Washington, DC: U.S. Government Printing Office, 1986).

**In searching for a competitive advantage through technological innovations, therefore, domestic companies need to emphasize either technologies that are unattractive to developing countries or that apply to a limited range of resource conditions.** Developing countries are attracted to technologies that: 1) require minimal capital, 2) can be built quickly, 3) can be amortized rapidly, 4) have low operating costs (including low energy consumption), and 5) require minimal technical skills and supervision.<sup>9</sup> This implies, for instance, that developing countries with resources suited to SX/EW processing will favor this technology over pyrometallurgical methods, because relatively simple mixers and settlers replace grinding mills, classifiers, flotation cells, smelters, and all their controls, and recyclable organic solutions supplant grinding media and flotation reagents. More importantly, SX/EW is very flexible in its applications and can be run practically at any scale, which makes it very convenient for application in developing countries. Its few environmental control requirements also may become increasingly important outside the United States.

Although SX/EW is a technology that transfers easily, domestic copper companies still may gain from its use in situations not applicable in other countries. For example, while all porphyry ore bodies tend to have oxidized caps suitable for SX/EW methods, the United States maybe unique in having a large resource of previously uncatalyzed oxide ore bodies (apart from the porphyry caps) particularly amenable to SX/EW treatment. Such oxide ore bodies are one resource that could provide a domestic competitive advantage relatively immune to subversion through technology transfer in the short-term. Small-scale SX/EW plants also are very attractive for leaching old, "worked-out" mines and waste dumps, also prevalent throughout the Western United States.

New domestic operations in the near future are more likely to exploit smaller, relatively high-grade (e.g., 3 percent) deposits, while overseas operations that wish to capitalize on foreign ex-

change will prefer large ore bodies. The technology transfer advantages here depend on the type of operation and the goal of copper production. For in situ leaching, this may confer an advantage on U.S. greenfield operations, which will emphasize small deposits until the technology is proven.

For sulfide ores, foreign and domestic operations will remain dependent on pyrometallurgical processing in the near-term. While the United States has a clear advantage here in the productivity of their operations, this is largely negated by lower foreign labor costs and the difference in environmental control requirements. Any imposition of air quality control regulations in foreign countries would benefit domestic companies in several ways, including a "leveling of the playing field" on environmental control costs, their advantage in acid plant operating experience, and the ability to market control technology.

**The rapidity of technology transfer in the copper industry does not mean that we should stop investing in innovation.** In the period before an innovation becomes standardized, its developer enjoys a competitive advantage. In addition to direct investments, a variety of other policies—such as tax policies on capital income, depreciation policies, and policies to support R&D—may influence the pace of technological change and hence competitive advantage.

### Staying Power<sup>10</sup>

**A final measure of competitiveness is termed staying power: the ability to survive in the marketplace over the long-term despite short-term losses of cash or market share.** Staying power stems from low current operating costs and/or high exit barriers, including perceived and actual costs of closure.<sup>11</sup> A high-cost mine that also has high closure costs or operators willing to subsidize losses exhibits greater staying power. Its persistence in a depressed market also may exert

<sup>10</sup>Barbara J. Evans, "How To Assess the Staying Power of World Copper Mines," *Engineering & Mining Journal*, April 1986.

<sup>11</sup>closure costs at 10 large open-pit copper mines in the Western United States that closed between 1981 and 1983 were between \$0.20/lb and \$0.22/lb of lost copper production during a 12-month closure period.

<sup>9</sup>United Nations Industrial Development Organization (UNIDO), *Technological Alternatives for Copper, Lead, Zinc and Tin in Developing Countries*, report prepared for the First Consultation on the Non-ferrous Metals Industry, Budapest, Hungary, July 1987.

downward pressure on the price to a level that forces competitors with less staying power to close. Thus it is more the staying power of competitors than their profitability that affects a company's relative outlook.

Competitive rankings based solely on cost of production distort the relationship between competitive strength and profitability. Competitive strength is the ability to maintain a position in the market. This ability is a prerequisite, but not a guarantee of profitability. Competitive strength and profitability depend on different cost considerations. The former is a function of operating cost and price, while the latter depends not only on earnings, but also on exit barriers. Only when operating earnings drop below the cost of withdrawing from the market does a facility stand to lose its staying power.

Comparing staying power in governmental operations is more difficult. Closing a State-owned mine is touchy—it creates unemployment and degrades foreign exchange. Operating losses can be sustained so long as mineral sales generate enough foreign currency to cover the foreign-currency portion of operating costs. But many State-owned mines that operated throughout the recent recession did not have to be subsidized because they are strong, low-cost competitors. In other cases, subsidization was a sound business decision to endure operating losses to avoid even greater direct closure costs. To determine the staying power of operations with persistent subsidization, overall closure costs can be set equal to the country's debt capacity, as a worst-case measure. As noted previously, debt will become a more important consideration for future capital investments at copper operations in LDCs.

## FEDERAL POLICIES AFFECTING COMPETITIVENESS

Federal policy toward an industry can be expressed in legislation, executive orders, treaties, rulings of commissions, government participation in international organizations, etc. There is no comprehensive national industrial policy, let alone a national minerals policy. Depending on the philosophy of individual administrations, measures directly related to competitiveness (such as trade relief) often meet with little success. Similarly, the policies with the most far-reaching impacts on the competitiveness of the U.S. copper industry may have been instituted for reasons totally unrelated to copper markets (e.g., environmental regulation).

Current Federal policies with potential impacts on the competitiveness of the domestic copper industry include those related to taxation, trade, defense, the environment, R&D, industrial development in general, and foreign aid. This section reviews all of these policy areas except foreign aid, which is discussed in ch. 3.

The effects of these policies on the U.S. copper industry vary. Decisions under various trade initiatives generally have gone against the industry. When coupled with U.S. contributions to in-

ternational loans that contributed to gluts in the copper market, trade and foreign policy have had significant adverse impacts on competitiveness. On the other hand, government denial of trade relief during the 1980s forced the copper industry to pull itself up by its own bootstraps—in part through investments in new technology and increased productivity. These efforts are discussed in the following section.

Environmental regulation also has been very costly to the industry (although beneficial to society as a whole). Even here, however, the primary impacts (smelter closure or the capital cost of new smelters) have run their course. Barring any further changes in environmental control requirements, the remaining burden is in slightly higher operating costs compared to countries without similar environmental controls.

Other policy measures, such as tax policy, can be very beneficial, depending on a company's capital structure and investments. Still others, e.g., defense policy and the present modest Federal investments in R&D and industrial incentives related to education and training, are neutral or provide small benefits.

## Federal Tax Policy

Governments have long used tax provisions to further objectives such as raising revenues, promoting economic development, and conserving resources. For capital intensive industries like mining, the tax regime can make or break a particular project. Thus, **taxation relative to that of other producing nations is an important element in the domestic copper industry's competitive position.**

The major copper producing countries have different tax regimes, which include income taxes as well as sales, social security, capital, and severance taxes, and royalties. In the United States, Canada, and Australia, copper companies also are subject to State or Provincial taxation. Of all these taxes, national income taxes probably are the most critical in determining an industry's international competitiveness. Moreover, income taxes are the favored tax route for providing benefits to a specific industrial sector. The effects of specific tax provisions on an industry also can vary widely over time depending on economic variables such as the price of the goods produced, the age of capital investments in plant and equipment, inflation rates, etc.

A 1986 study (i.e., before the Tax Reform Act of 1986) of the structure of international mineral income tax systems found the U.S. tax regime very competitive.<sup>12</sup> Based on a hypothetical 20-year copper/gold mine in British Columbia, that study examined the top marginal income tax rates, capital cost recovery, investment-related incentives (e.g., investment tax credits, depletion deductions) and other deductions, and the resulting tax base as a percentage of discounted operating cashflow for 8 major copper producing countries.<sup>13</sup> In addition, the study discussed the sensitivity of effective tax rates to changes in profitability, inflation rates, and product price cy -

cles.<sup>14</sup> Although the U.S. minerals industry had the second highest marginal tax rate, they had the second lowest income tax base, primarily due to generous investment incentives and other deductions (see table 10-2),

According to the Congressional Budget Office (CBO), **before tax reform the U.S. mining industry benefited more than any other sector from preferences that reduced its taxes.**<sup>15</sup> The two most important tax provisions targeted specifically at the mining industry are depletion allowances and expensing of exploration and development costs, both continued under the 1986 Act. Other pre-1986 tax benefits applicable to all industries included the accelerated cost-recovery system (ACRS) and the investment tax credit.

The depletion allowance enables mineral producers to deduct a percentage of taxable net income based on either investment cost or a specified fraction of gross sales from the minerals extracted, whichever is higher. In recent years, the depletion allowance has been limited to 50 percent of taxable net income. In theory, Congress intended this allowance to stimulate exploration and thus provide for the replacement of depleted mineral properties. In effect, a mineral property usually is so long lived that the company is able to write off its original investment several times over. CBO estimated the excess of percentage depletion over cost recovery for non-fuel minerals to be \$300 million in FY 1984.<sup>16</sup> Because the allowance is tied to revenues, it will vary depending on the health of the industry, however.

The minerals industry also may deduct a maximum of 70 percent of the cost of exploration and development in the year incurred, and capitalize the remaining 30 percent over a 5-year straight-

<sup>12</sup>Keith Brewer et al, "Fiscal Systems," paper presented at the Conference on Public Policy and the International Competitiveness of North American Metal Mining, Golden, CO, January 1987.

<sup>13</sup>Australia, Canada, Chile, Peru, Papua New Guinea, South Africa, United States, and Zambia.

<sup>14</sup>The United States was not included in the sensitivity analyses for profitability and inflation, but our pre-reform tax regime was similar to Canada's and the results should be comparable.

<sup>15</sup>U.S. Congress, Congressional Budget Office, *Federal Support of U.S. Business* (Washington, DC: U.S. Government Printing Office), January 1984.

<sup>16</sup>Ibid. see also Paul R. Thomas et al., *The Depletion Allowance and Domestic Minerals Availability: A Case Study in Copper* (Washington, DC, U.S. Bureau of Mines, Information Circular 8874), 1982.



Table 10.2.—Mineral Income Tax Comparisons

Country	Top marginal rate	Total deductions		Tax base <sup>a</sup>	Base case (5% IRR)	Profitability		Inflation	
		Capital cost and investment recovery	incentives			Low (5% IRR)	High (23% IRR)	5% prices	Cyclical prices
Australia <sup>b</sup> . . .	49.0%	51.0%	73.0%	27.2%	100	333	77	104	105
Canada . . . . .	45.3	50.7	74.7	25.3	100	144	120	127	97
Chile . . . . .	40.0	53.0	56.7	40.6	100	174	93	113	102
Peru, . . . . .	57.0	52.0	64.0	35.5	100	178	97	110	97
PNG <sup>d</sup> . . . . .	35.0	48.0	48.0	52.0	100	211	85	113	102
South Africa . . .	46.2	53.0	60.5	37.3	100	128	100	114	98
United States <sup>e</sup>	54.2	48.5	76.5	23.5	100	NA	NA	NA	91 <sup>f</sup>
Zambia . . . . .	45.0	53.0	15.5	16.5	100	0	175	175	75

<sup>a</sup>As a percent of operating cashflow; calculations based on a 15 pre-tax IRR mining project over a period of 20 years. Cashflows and tax bases are discounted at 5%.

<sup>b</sup>Based on Queensland.

<sup>c</sup>Arithmetic average of results of Quebec, Ontario, Manitoba, and British Columbia. Only Federal and provincial income taxes are considered.

<sup>d</sup>PNG tax system has a top marginal rate of 70% which is triggered only at a very high profitability level.

<sup>e</sup>Arithmetic average for States of Utah and Alaska, only Federal and State taxes are considered. Based on tax code before tax reform of 1986.

<sup>f</sup>For Alaska only.

SOURCE: Keith Brewer et al. "Fiscal Systems," paper presented at the Conference on Public Policy and the International Competitiveness of North American Metal Mining, Golden, CO, January 1987.

line depreciation schedule.<sup>17</sup> This defers a portion of income taxes until the deductions have been taken. For development expenditures, only the amount that exceeds the net receipts of the mine for a given year may be included, CBO estimated that expensing and depreciation under the old 80/20 formula amounted to \$60 million for the non-fuel minerals industries in FY 1984.<sup>18</sup> The minerals industry notes that other industries receive similar benefits through tax credits for research and deductions for new product development.

While the Tax Reform Act of 1986 reduced the top corporate tax rate from 46 percent to 34 percent, it also set the minimum tax at 20 percent and significantly reduced investment incentives and other deductions. In addition, the 1986 law limited the use of foreign tax credits, repealed ACRS and the investment tax credit, and changed the depreciation schedule for mining equipment from 5 years at 150 percent to 7 years at 200 percent. The percentage depletion allowance and expensing of exploration and development costs were retained.

**With the possible exception of effects on financing foreign operations, U.S. minerals companies do not view the new tax regime as bring-**

**ing major changes for them.** Their current focus on restructuring and modernization, rather than expansion, does not raise any immediate concerns about the tax changes. Those expansions that are planned are primarily solvent extraction and electrowinning facilities, with a low capital cost compared to smelters. Smelting and refining are capital intensive, and new facilities will be less attractive under the new tax system. Companies face so many other problems with a new smelter (such as environmental costs), however, that it is unlikely that taxation would be the deciding factor, Mining is more oriented toward labor and equipment costs than capital investment and may gain a slight tax advantage.<sup>19</sup>

Instead, **it is the conditions the U.S. economy and its minerals industry might face in the next 5 to 10 years that may raise questions about tax policy.** The lower top tax rate benefits profitable projects more than marginal ones.<sup>20</sup> While this rewards success, and thus sends appropriate market signals, it also can significantly reduce government revenues, and budget pressures may lead to a rate increase once again.

Accelerated depreciation allowances minimize the effect of cyclical prices on effective tax rates.

<sup>17</sup>These are the allowances under the Tax Reform Act of 1986. Previously, industry was allowed 80 percent expensing, with 20 percent capitalizing.

<sup>18</sup>CBO, supra note 15.

<sup>19</sup>John J. Schanz, Jr. and Karen L. Hendrixson, "Impact of Existing Federal Policies on the Copper Industry," Congressional Research Service report prepared at the request of the Subcommittee on Oversight and Investigations of the Committee on Energy and Commerce, U.S. House of Representatives, July 1986.

<sup>20</sup>Brewer et al, supra note 12.

Firms are able to claim greater amounts of depreciation during periods of higher profits. The capital cost recovery system for the U.S. minerals industry did not change significantly, so the industry's taxes should remain relatively sensitive to cyclical prices. A switch toward more rigid depreciation schedules similar to the accounting treatment of capital costs would result in higher effective tax rates for mining. This change was discussed extensively in the debate over the Tax Reform Act of 1986, but was not included in the final package.<sup>21</sup>

The repealed investment incentives and deductions also are less valuable to the more profitable projects. The investment tax credit primarily provided inflation protection for capital intensive ventures. During periods of low inflation, this fixed investment incentive can result in very low effective tax rates. Thus, while its removal should increase government revenues over the short term, it also makes the current tax regime relatively insensitive to inflation. A return of high inflation rates could lead to heavy industry pressure to reinstate the credit or other investment incentives.<sup>22</sup> Incentives also could be used to encourage investment in heavy industry and new technology to increase productivity in the event of a recession.

pressure to raise revenues in order to decrease the U.S. budget deficit may lead to higher tax rates for industry in the short term. Obvious targets would include increasing the maximum tax rate, and adjusting the depletion allowance and expensing of exploration and development costs, which represent the greatest amount of foregone revenues from the minerals industry.

A final aspect of tax policy that might be considered affects copper consumers. If the conditions that occurred during the early 1980s—lower-cost imports taking over an increasing share of the domestic market and a significant decline in U.S. copper production—were to recur, tax incentives could be used to stimulate the purchase of domestic copper. Thus, consumers who paid more for U.S. copper might be subsidized through a tax deduction or credit tied to the

difference in cost between foreign and domestic copper.

## Trade Policy

International trade and financing activities in the copper industry have been highly contentious in recent years. **The U.S. industry has been severely critical of some foreign operations' refusal to curtail production in light of the oversupply conditions existing in the world market. Domestic producers have sought to curb these foreign activities through legislation, appeals to the International Trade Commission, and other political and legal means, but have been largely unsuccessful.**

Because global copper trading, pricing, and financing are highly developed and integrated, few market activities have single, isolated effects.<sup>23</sup> Instead actions in one part of the market are quickly felt throughout the world. The high level of U.S. imports subjects domestic producers to constant competitive pressures from the world market.<sup>24</sup> During the past decade, as imports gained an increasing share of the domestic market, the U.S. copper industry requested on several occasions that the Federal government relieve the foreign pressure through a variety of trade measures. Some of the requests claimed that the domestic industry needed trade relief in order to restructure and modernize. Others complained that differing business environments in the United States and abroad result in advantages for foreign producers.<sup>25</sup> A few charged that foreign activities violate international trading codes (such as the General Agreement on Tariffs and Trade, GATT) and their counterparts in U.S. law.

## Section 201 Cases

The most publicized copper industry complaints were the Section 201 cases filed in 1978

<sup>23</sup>The copper market is characterized by high levels of trade (in 1985, trade accounted for 23, 11, and 40 percent of NSW production of ores and concentrates, blister, and refined copper, respectively), a very mature world pricing system, and a high level of international investment (see ch. 3).

<sup>24</sup>The United States is the world largest importer of refined copper. In 1986, U.S. imports totaled 502,000 tonnes of refined copper, accounting for almost a quarter of consumption (see ch. 4).

<sup>25</sup>The catch phrase used in this argument is that an "uneven playing field" exists in the copper industry.

<sup>21</sup> Ibid.  
<sup>22</sup> Ibid.

and 1984. Sec. 201 of the Trade Act of 1974 (also called the Escape Clause) is designed to provide temporary import relief to domestic producers seriously injured by increased import competition.<sup>26</sup> The relief is to be used for economic adjustment programs, such as restructuring and modernization. The fairness of trading practices (e.g., dumping or subsidization) is not at issue in Sec. 201 cases; those matters are handled in antidumping and countervailing duty cases (see below).

Sec. 201 requires that an industry convince both the International Trade Commission (**ITC**) and the President that it merits trade relief. First, the ITC determines whether imports have caused the domestic industry serious injury, and if so, recommends trade actions to prevent or remedy the injury.<sup>27</sup> The remedies that the **ITC may recommend** are limited to tariffs, quotas, tariff-rate quotas, and trade adjustment assistance for workers. If the ITC finds serious injury, the President must review the case, and either provide import relief or determine that doing so is not in the national economic interest. Whereas the ITC's determination centers on imports and the health of the domestic industry, the President's decision is based on a broader concept of economic interest that also includes the well being of workers and consumers and strategic concerns. If the President decides that relief is appropriate, it can take the form of the ITC's recommendations; a different package of tariffs, quotas, and tariff-rate quotas; or negotiation of orderly marketing agreements (bilateral agreements to restrict imports into the United States).

<sup>26</sup>A concise description of Section 201 as well as other aspects of U.S. trade law appears in, U.S. House of Representatives Committee on Ways and Means, Subcommittee on Trade, Overview of Current Provisions of U.S. Trade Law, USGPO WMPC:98-40 (Washington, DC: 1984).

<sup>27</sup>The ITC must "determine whether an article is being imported into the United States in such increased quantities as to be a substantial cause of serious injury, or the threat thereof, to the domestic industry producing an article like or directly competitive with the imported article." Substantial cause is defined as "a cause which is important and not less than any other cause." If the ITC makes an affirmative injury determination, it must (1) find the amount of the increase in, or imposition of, any duty or other import restriction which is necessary to prevent or remedy the injury, or (2) if it finds that adjustment assistance can effectively remedy the injury, recommend the provision of such assistance.

**In 1978 and again in 1984, the ITC found that rising imports were causing serious injury to the domestic copper industry and recommended that the president remedy the injury.<sup>28</sup> In both instances, the president denied import relief because it was deemed not in the national economic interest.** In the 1984 case, the ITC's findings were sent to the President 2 months before the presidential election. Such timing is usually a political advantage for the domestic industry because of the voting power and campaign contributions of those who may benefit from trade relief. Despite this pressure, President Reagan ruled that import relief was not in the national economic interest due to the potential damage to copper fabricators (which have more employees than the mining and processing industry), and the inconsistency of such relief with the President's free trade philosophy. The existence of the Carbon Steel Sec. 201 case, on which the President had to decide shortly thereafter, was probably an additional reason for denying help. If the copper industry were granted trade relief, the steel industry would have merited equally generous measures.

Although trade relief was denied in the 201 cases, the proceedings' publicity yielded some secondary benefits. The attention brought to the industry's plight by the 1984 case probably helped producers negotiate wage and benefit concessions from labor unions and rate decreases from electric utilities. The cases also highlighted the problem of access to markets. Some foreign companies' production strategies are now more likely to consider the impact on U.S. competitors in order to avoid conflicts.<sup>29</sup>

### Unfair Trading Cases (Antidumping and Countervailing Duty)

Antidumping cases allege selling prices of less than fair value. Countervailing duty cases claim subsidization. These tend to be narrower in scope and usually are publicized less than Sec. 201

<sup>28</sup>Both cases covered unwrought, unalloyed refined copper. The 1984 case also covered black copper, blister copper, and anode copper.

<sup>29</sup>Jose Luis Mardones and Isabel Marshall, "Lobbying by ExPorters: The 1984 Copper Import Case," paper presented at the Copper 87 Conference, Vina del Mar, Chile, Nov. 30 to Dec. 3, 1987.

cases. The fabricated copper products industry has filed several of these unfair trading cases. In 1986, the **ITC** and the Commerce Department found that the brass sheet and strip producers were being injured by imports from Brazil, Canada, South Korea, France, Italy, Sweden, and West Germany that either were subsidized or sold at less than fair value (i. e., dumped).

### Copper Trade Legislation

Because of the industry's troubles, copper trade has been the subject of a number of bills considered by Congress in the early 1980s. The proposed legislation has dealt primarily with the oversupply situation in the copper market. An example is the Trade Act of 1984, which contained a nonbinding clause stating that the U.S. government should negotiate with foreign copper producers for lower copper production in order to raise the price. President Reagan denied this request, citing the infeasibility of negotiating the required agreements (Chile in particular showed signs of being uncooperative); potential antitrust violations in getting the required cooperation among U.S. producers; and the negative effects of increased costs for consumers. Congress included a binding version of this clause as an amendment to the Textile and Apparel Trade Enforcement Act of 1985, but that bill was vetoed by the President.

Another example is the Minerals and Materials Fair Competition Act of 1987 (S. 1042), which has yet to be reported out of the Senate Finance Committee. This legislation would amend many U.S. trade statutes to recognize subsidized excess foreign capacity as a source of injury to producers of nonagricultural fungible goods (including copper).<sup>30</sup> In addition, the Act would establish that a principal U.S. negotiating objective within GATT would be an agreement imposing sanctions against providing subsidies for excess capacity. Furthermore, the bill instructs U.S. representatives to the International Monetary Fund (IMF) to ask for a ban on loans or other financing assistance from the Compensatory Financing Facility (CFF) to countries that do not agree to adjust pro-

<sup>30</sup> Ma, or statutes that would be amended by the Minerals and Materials Fair Competition Act of 1987 include Section 301, Section 201, and antidumping and countervailing duty provisions,

duction and to refrain from adding further capacity. In the absence of an overall IMF ban, the U.S. representatives are to vote against all CFF loans to countries that do not agree to adjustments.

An excess capacity subsidy provision also was included in the Senate version of the Omnibus Trade and Competitiveness Act of 1987. The provision classified as an unreasonable trade practice foreign subsidization of industries that produce non-agricultural goods for which worldwide production exceeds demand. This provision did not make it into the conference report that was passed by both houses of Congress in 1988.

In 1984 and 1985, Congress also considered bills to increase the duty on imported copper in an amount that would offset the cost to the domestic industry of complying with environmental regulations. In 1984, legislation was passed that suggested that copper be given higher priority within the stockpile, and added a "Buy America" clause to the stockpile.

### U.S.-Canada Free Trade Agreement

The United States and Canada signed an accord in January 1988 that seeks to liberalize trade and investment between the two countries. This bilateral agreement would eliminate all tariffs on goods trade by 1998, reduce nontariff trade barriers, establish rules for bilateral investment, and create a dispute settlement mechanism.<sup>31</sup> To be enacted, the U.S.-Canada Free Trade Agreement (FTA) must be approved by the U.S. Congress and the Canadian Parliament.

**The FTA is opposed by several major copper producers,** represented by the Non-Ferrous Metals Producers Committee (NFMPC),<sup>32</sup> primarily because it fails to prohibit some Canadian subsidization practices. They are concerned that

<sup>31</sup> The accord also deals with services trade, business travel, energy and national security concerns, and some outstanding trade issues.

<sup>32</sup> The Non-Ferrous Metals Producers Committee (NFMPC) is a trade association whose members are Asarco Phc'ii) Dodge and the Doe Run Co. (a lead producer based in St. Louis, MO) Their position on the FTA is outlined in the statement by Robert J. Muth, President, before the Mining and Natural Resources Subcommittee of the Interior and Insular Affairs Committee of the U.S. House of Representatives, March 10, 1988. In addition to subsidies, the NFMPC is against the FTA because it weakens judicial review in unfair trade cases and eliminates the tariff on imports of Canadian copper.

**Canadian copper companies are using below-market-rate capital from various national and provincial government assistance programs to modernize facilities.** As an example, the NFMPC cites the C\$83 million loan from a government acid rain program for modernization and pollution control at Noranda's copper smelter at Rouyn, Quebec. Noranda does not have to repay the loan through monetary reimbursement; it may substitute "additional investments aimed at maintaining its commitment to Quebec's copper industry."<sup>33</sup> There also have been suggestions that subsidies may be made available to reopen Noranda's Gaspé copper mine in Murdochville, Quebec (closed in April 1987 because of a fire), and to the Hudson Bay Mining and Smelting Co. copper smelter at Flin Flon, Manitoba. **These subsidies are especially disturbing to the U.S. producers because half of the increase in copper imports since 1985 came from Canada.** Moreover, even after modernization, Canadian smelters will control less than half as much sulfur dioxide as U.S. smelters.

The FTA does not actually sanction the subsidization programs, but leaves their legality to be resolved by a bilateral working group established to iron out the differences between U.S. and Canadian unfair trade law. Until the group finishes its work (up to 7 years), both countries would apply their own antidumping and countervailing duty laws to any disputes that may arise. For cases under these laws that are investigated during this interim period, the FTA comes into play at the end of the proceedings, after the ITC and the Commerce Department (or their Canadian counterparts) have made their final determinations. Independent binational panels would review contested determinations for their consistency with the laws of the country that made them; national courts currently undertake such review.<sup>34</sup>

<sup>33</sup>"Copper," *Metals Week*, vol. 59, No. 20, May 16, 1988.

<sup>34</sup>In the United States, an unfair trade case can be concluded once the ITC and the Commerce Department have made their findings. Quite often, however, the determinations of these agencies are challenged before the U.S. Court of International Trade.

## Miscellaneous Domestic Trade Developments

The Generalized System of Preferences (GSP) program allows certain products to be imported duty-free into the United States from LDCs to promote their economic development. In December 1987, Chile's benefits under the GSP program were rescinded because it was determined that Chile consistently denies its workers basic labor rights.<sup>35</sup> This, however, does not cover a great deal of copper trade because blister, anode, and refined copper from Chile were already excluded from the GSP program.

## Miscellaneous International Trade Developments

In 1984, the European Economic Community (EEC) complained to the GATT Council that Japanese tariffs were pushing European companies out of the copper ore and concentrates markets. Japanese tariffs are high for refined copper, but low for concentrates (see discussion of trade in ch. 4). The EEC claimed that this tariff schedule allowed Japanese copper smelting and refining firms to consistently pay higher prices for concentrates than European firms could afford, thus assuring raw material supplies for themselves to the detriment of European competitors.<sup>36</sup> Some domestic copper producers also had protested the Japanese practices to the U.S. government since their inception in the late 1960s and early 1970s, but without avail.

In 1984, a working group was created within GATT to study international trade problems affecting nonferrous metals and minerals. The group is to identify measures taken by importing and exporting countries that hamper world trade, and make recommendations on how trade might be liberalized.

Since 1985, the United States has been working with other copper producing countries to

<sup>35</sup>Under authority of the Generalized System of Preferences Renewal Act of 1984.

<sup>36</sup>Janice L.W. Jolly and Dan Edelstein, "Copper," 1984 *Minerals Yearbook, Volume 1*, (Washington, DC: U.S. Department of the Interior, Bureau of Mines, 1986).

establish a Producer/Consumer Forum patterned after the International Lead Zinc Study Group. This organization will compile copper statistics, develop quantitative information on existing capacities and end-uses, and provide a forum for discussions about the problems and opportunities of the copper industry.<sup>37</sup> It will play only a minimal role in market development activities such as advertising and promotion. The Forum will be autonomous rather than meet under the auspices of United Nations Conference on Trade and Development (UNCTAD).<sup>38</sup>

### Intergovernmental Council of Copper Exporting Countries (CIPEC)

Most of the major world copper producing countries (Chile, Peru, Zambia, Zaire, Indonesia, Australia, Papua New Guinea, and Yugoslavia) belong to the Intergovernmental Council of Copper Exporting Countries (CIPEC). Established in 1967, this trade association conducts marketing studies, disseminates information on copper developments, and seeks to promote expansion in the industry. During 1974-76, in the wake of OPEC's success in raising oil prices, CIPEC attempted to establish itself as a cartel. It tried, but failed, to stabilize then falling copper prices through production cutbacks. The group has discussed price stabilization numerous other times but has been unable to agree on a program, and CIPEC's power to manage supply and stabilize markets has never been established.

### Defense Policies

**Copper is a strategic material—one that is essential in the production of equipment critical to the U.S. economy and the national defense.**

In 1986, the United States imported around 27 percent of its refined copper consumption. This is more than the total amount used by the electrical and electronics industry in 1986. The principal sources of imports were Chile (40 percent),

<sup>37</sup>Janice L. W. Jolly, "Copper," 1985 *Minerals Yearbook, Volume 1*, (Washington, DC: U.S. Department of the Interior, Bureau of Mines, 1987).

<sup>38</sup>Creation of the group was first proposed at an ad hoc meeting convened by UNCTAD to review copper market conditions

Canada (29 percent), Peru (8 percent), Zambia (7 percent), and Zaire (6 percent).<sup>39</sup>

While neither political instability nor hostility is a major concern about the security of supplies from these countries, their imports can be subject to disruption. For example, one of the most disruptive interruptions in U.S. materials supply in the last 30 years was the loss of nickel from Canada during the 4-month labor strike against the Canadian nickel industry in 1969. At that time, Canada supplied 90 percent of U.S. primary nickel supplies.<sup>40</sup> A similar occurrence in Canada's copper industry would cut off U.S. imports equivalent to the amount used for consumer goods, military applications, and chemicals in 1986.

Moreover, **supplies do not actually have to be interrupted to have significant economic impacts on U.S. mineral markets.** A rebel invasion of Zaire's mining country in 1978 led to fears of a cobalt shortage that stimulated panic buying. Prices went through the roof, and domestic users turned to cheaper substitutes and recycling where possible. However, mining and processing facilities were closed only briefly, and cobalt production in Zaire and Zambia actually increased 43 percent in 1978 and 12 percent in 1979.<sup>41</sup> The transportation routes from the mining districts in Zaire and Zambia are considered very insecure because the rail lines pass through Angola, Mozambique, or South Africa.

Potential supply interruptions of imported copper are not considered as critical as those for metals such as chromium and cobalt, which are not produced in the United States and do not have readily available substitutes. The economic consequences of a supply shortfall could be severe for U.S. industry, however. The price of copper and its substitutes would increase dramatically. It would take anywhere from 6 months to sev-

<sup>39</sup>Janice L. W. Jolly and Daniel Edelstein, "Copper," *Mineral Commodity Summaries: 1987* (Washington, DC: U.S. Department of the Interior, Bureau of Mines) 1987.

<sup>40</sup>U.S. Congress Office of Technology Assessment, *Strategic Materials: Technologies To Reduce U.S. Import Vulnerability* (Washington, DC: U.S. Government Printing Office, OTA-ITE-248) May 1985.

<sup>41</sup>Ibid.

eral years to bring U.S. idle mine capacity and unexploited reserves into full production. Companies would not be willing to incur the capital investment to do so without assurances that production would continue for long enough to recoup the investment. Moreover, most imports are in the form of refined and unmanufactured copper. Replacing these would require either drastic increases in SX-EW capacity, or the reopening of currently idle smelter capacity (and thus substantial capital investment in new furnaces and pollution control), or a massive recycling effort.

The United States has long had legislative policies designed to provide either supplies of copper or additional productive capacity in the event of a supply interruption that threatens national security. This legislation includes the Strategic and Critical Materials Stock Piling Act of 1946 and the Defense Production Act of 1950.

### The National Defense Stockpile

Congress first authorized stockpiling of critical materials for national security in 1939. World War II precluded the accumulation of stocks, and it was not until the Korean War that materials stockpiling began in earnest. Since then, U.S. stockpile policy has been erratic and subject to periodic, lively debate over the amount of each commodity to be retained and over the disposal of stockpiled items for budgetary reasons.

Stockpile goals are currently based on having a 3-year supply of materials needed to meet national defense and industrial needs in a defense emergency.<sup>42</sup> A transaction fund dedicates revenue from Federal sales of stockpile excesses to the purchase of materials short of stockpile goals.<sup>43</sup> In 1986, the total stockpile inventory was valued at approximately \$10 billion. If the stockpile had met all goals, it would have been valued at about \$16.6 billion in 1986.<sup>44</sup>

<sup>42</sup>The number of years supply needed is set according to the anticipated duration of a hypothetical emergency, not according to the leadtime needed to replace foreign supplies with domestic sources.

<sup>43</sup>Strategic and Critical Materials Stock Piling Act of 1979, Public Law 96-41, 50 U.S.C. 98 et seq.

<sup>44</sup>Federal Emergency Management Agency, *Stockpile Report to the Congress: October 1985-March 1986*, FEMA36, 1986.

**Copper is a strategic commodity in the National Defense Stockpile. The current goal is 1 million short tons, with a 1986 inventory of 22,297 tons of copper, plus 6,751 tons of copper contained in 9,645 tons of brass.**<sup>45</sup>

**Over the years stockpile acquisitions and releases have affected copper supply and price.** In 1954, market shortages due to a labor strike led to the release of 40,000 tons. From 1959 to 1963, stockpile acquisitions combined with copper labor strikes and strong economic expansion to push prices upward.<sup>46</sup> The most significant releases—550,000 tons—occurred in 1965-66 under a declaration of national emergency due to the Vietnam War. These releases occurred at a time of growing demand, disturbances affecting overseas production, and rising domestic prices. Consumers welcomed the resultant downward pressure on prices, but others alleged that the stockpile was being used as an economic buffer rather than for defense. Q'

In the early 1970s, the overall stockpile objectives were reduced to a 1-year supply, and the copper target was reduced to zero. Virtually all of the copper remaining in the stockpile was sold during the commodity price boom of 1974. In 1979, Congress reinstated the 3-year planning period for defense emergencies, and the copper goal was set at 1 million tons,

Most recently, legislation was introduced in the 98th Congress (1983-84) to purchase copper for the National Defense Stockpile to prod the sluggish markets. Opponents argued that the acquisitions would have been insufficient to reopen any shutdown operations, and would have established a precedent of allowing economic considerations to supersede defense needs.

**Bringing the stockpile up to its goal of 1 million tons would require the purchase of almost 971,000 tons of copper. This is equivalent to 90 percent of 1986 U.S. primary refinery production, and 13 percent of Western world production.** Even if spread over several years, such purchases would exert significant upward pressure

<sup>45</sup>Ibid.

<sup>46</sup>U.S. Department of the Interior, Bureau of Mines, *Minerals Yearbook*, various years,

<sup>47</sup>Sc ha n z and t l e n d r i x s o n, s u p r a n o t e 19.

on copper prices during periods of low demand or excess supply. While this could help the U.S. industry weather a market slump, it also could send false market signals to foreign producers, and encourage overbuilding of capacity.

### The Defense Production Act

The Defense Production Act of 1950 (DPA) provides several mechanisms for assuring availability of materials and industrial capacity needed for national security. Title I authorizes the setting of government priorities for materials allocation in a national emergency or war. Title III provides loans or loan guarantees for corporate activities that would expedite production in the event of a national emergency. These include expansion of capacity, development of technological processes, or the production of essential materials, including exploration, development and mining of strategic metals. **Under DPA, the government also may purchase metals and minerals for government use or resale.**

In the 1984 reauthorization of DPA, Congress established new procedures for authorization of Title III projects in the absence of a national emergency or war.<sup>48</sup> The law requires the President to determine that Federally-supported projects meet essential defense needs and that the Federal support offered would be the most "cost-effective, expedient, and practical alternatives for meeting the need." Industrial resource shortfalls for which Title III assistance is sought must be identified in the budget submitted to Congress.

Numerous DPA contracts and agreements were established between 1951 and 1956, when copper was in short supply. These involved government loans, direct purchases, subsidies of otherwise uneconomical output, and accelerated amortization for income tax purposes. Between 1951 and 1958, the Defense Minerals Exploration Administration offered loans of up to 50 percent government participation for copper exploration. In 1967, when copper was again in short supply, the Duval Company's Sierrita mine received a \$56 million loan. **The DPA has not been used to support the domestic copper industry since**

**1969, when the last copper exploration participation contract expired.**<sup>49</sup>

Although DPA provisions generally have been used to encourage mining of strategic minerals, the law also could be used to ensure adequate smelting and refining capacity to meet domestic national security needs, and to develop advanced technologies considered desirable for enhancing the security of domestic resources.

### Environmental Regulation

**The copper industry is subject to numerous Federal and State regulatory requirements related to environmental protection and worker health and safety.** These range from the preparation of an environmental impact assessment prior to initiating a mining project, to the control of air and water pollution during mining and processing, to the reclamation of tailing piles and dumps when an operation closes. Throughout, operations are scrutinized by the Mine Safety and Health Administration and the Occupational Health and Safety Administration. Other types of legislation either regulate the location of mines on public lands or withdraw those lands from mining altogether.

This section briefly reviews the major Federal programs and discusses their effects on competitiveness; the pollutants of concern and technologies for their control are described in chapter 8. It is important to note that individual States also may have relevant legislation (especially related to groundwater protection) that imposes additional standards and permitting, inspection, and enforcement requirements.

### The National Environmental Policy Act

The National Environmental Policy Act of 1969 (NEPA) requires, for "major Federal actions significantly affecting the quality of the human environment" (e.g., leasing Federal land for mining), that an agency prepare a statement that describes possible environmental impacts, any adverse effects that cannot be avoided (including irreversible commitments of resources), and alternatives to the proposed action and their impacts,

<sup>48</sup>Public Law 98-265,

<sup>49</sup>Schanz and Hendrixson, *Supra* note 19.



New copper mines are opened infrequently in the United States, and copper companies rarely have to go through the NEPA process. When they do, however, it can be time consuming and expensive to provide all of the data needed by the agency preparing the environmental impact statement (EIS). Moreover, because of the extensive public participation in the NEPA process, it is often the largest source of delay in any new venture that comes under its aegis.

### The Clean Air Act

The Clean Air Act sets standards for both ambient concentrations of pollutants and emissions from individual sources. The National Ambient Air Quality Standards (NAAQS), which address ambient concentrations, include primary standards designed to protect human health and secondary standards to safeguard public welfare. The Environmental Protection Agency (EPA) has set primary and secondary standards for sulfur oxides, particulate matter, nitrogen dioxide, hydrocarbons, photochemical oxidants, carbon monoxide, ozone, and lead.

Every major new source of emissions (e.g., a new smelter furnace) is required to undergo a preconstruction review to ensure it will not violate NAAQS. Sources in dirty-air areas, or at the opposite extreme, those where the air is already much cleaner than the standards require, are subject to more stringent permitting requirements for new sources. In addition, operating sources are required to use technological controls to meet emission limitations, which set quantitative limits on the amount of pollutants that can be released to the atmosphere.

At copper operations, the primary concerns are sulfur dioxide (SO<sub>2</sub>), particulate, and fugitive emissions from smelting and converting; and fugitive dust from tailings piles and waste dumps (see ch. 8). **At most smelters, meeting the emission limitations has meant completely changing smelting technology, including installing a new furnace, collecting the various gas streams, and treating them,** first in an electrostatic precipitator to remove the particulate, and then in an acid plant to convert the sulfur dioxide to sulfuric acid. The acid plant adds significantly to operating

costs. The sulfuric acid may be salable and provide a byproduct credit, but at most operations it is a red ink item. **While the furnace types that are amenable to sulfur dioxide control are more efficient than the old reverberatory furnaces, the gain in efficiency is offset by the capital and operating costs of control.** One copper company estimates the capital cost of modifying its smelter for pollution control at \$154 million, with a net gain of perhaps 1 cent/lb lower operating costs.

### The Clean Water Act

The Clean Water Act establishes water quality standards that focus on the uses of the waters involved, including public water supplies, fish and wildlife, recreation, and agriculture. The standards generally are achieved through effluent limitations that restrict the quantities, rates, and concentrations of chemical, physical, biological, and other types of discharges from individual sources. In general, the Act requires all categories of sources (including copper mines, mills, smelters, and refineries) to apply the best practicable control technology currently available in order to meet the effluent limitations.

Effluent limitations and water quality standards are implemented through State certification programs and through the National Pollutant Discharge Elimination System (NPDES). All point sources must obtain State certification that their operations will not violate any effluent limitations, water quality standards, or new source performance standards. They also must obtain a NPDES permit, which requires a demonstration that the discharge will meet all applicable water quality requirements. NPDES permits are issued under EPA-approved State programs.

Effluent limitations for copper mines, mills, and leach operations cover discharges of copper, zinc, lead, and cadmium, as well as total suspended solids and pH. Arsenic and nickel are not specifically mentioned in the standards because they are adequately controlled by the removal of other metals found in the discharges. Leaching operations generally are expected to achieve zero discharge unless the annual precipitation exceeds annual evaporation (rare in the arid and semi-arid copper-producing areas of the West-

ern United States). Guidelines are being developed for effluents discharged from primary copper smelters, copper refineries, and acid plants. These limitations aim to control the amount of arsenic, cadmium, copper, lead, zinc, and nickel in effluents; the pH of the discharge; and the concentration of total suspended solids.

### Safe Drinking Water Act

Congress enacted the Safe Drinking Water Act in 1974 to ensure that water from public drinking supplies is healthful. so Primary standards, or maximum contaminant levels (MCLs), are set based on the contaminant concentrations at which no known or anticipated adverse effects on human health occur, modified by the best available treatment technology (considering cost). Secondary standards set goals for contaminants that primarily affect the aesthetic qualities of drinking water.

The Safe Drinking Water Act also protects sole source aquifers, or those aquifers that supply 50 percent or more of the drinking water for an area, from contamination due to projects above the aquifer. It requires States to establish "well head protection areas" around public wells to prevent pollutants from entering underground supplies. EPA has designated the groundwater systems of the Upper Santa Cruz Basin and the Avra-Altar Basin of copper-producing Pima, Pinal, and Santa Cruz counties in Arizona as a sole source aquifer.<sup>51</sup>

### Resource Conservation and Recovery Act

The EPA regulates hazardous and other solid wastes under the Resource Conservation and Recovery Act (RCRA). Subtitle C of RCRA establishes regulations for the generation, transportation, treatment, storage, and disposal of materials identified by EPA as hazardous. Subtitle D provides Federal guidelines for EPA-approved State or Regional solid waste plans. These address the regulation of landfills, dumps, and ponds handling non-hazardous solid and liquid wastes. Box 8-C in chapter 8 discusses the EPA decision that solid

wastes from the mining and beneficiation of copper ores should be regulated under Subtitle D of RCRA as non-hazardous solid waste. The rationale for this decision was that the large volumes of mine waste would be very difficult to regulate under rules that had been designed to manage much smaller amounts of hazardous industrial and municipal waste. EPA also reasoned that Subtitle C does not allow considerations of environmental necessity, technological feasibility, and economic practicality, which are important given the magnitude of mine waste. The cost of mine waste management under Subtitle C of RCRA would result in closures at domestic mines and mills with very large amounts of waste material.

### Comprehensive Environmental Response, Compensation and Liability Act (Superfund)

Superfund allows the EPA to respond to actual or threatened leaks from inactive hazardous waste treatment, storage, and disposal facilities, and to notify the public of such releases. It also provides the authority and framework for cleanup of orphaned hazardous waste sites. Although mining wastes are exempt from RCRA Subtitle C regulation, EPA has made it clear that such materials are not exempt from Superfund. The EPA's policy on the continuing availability of the mining waste exclusion for inactive or closed facilities will affect the extent to which Superfund liabilities and obligations may arise from the closure



Photo credit: Vickie Basinger Boesch

The Douglas, Arizona smelter, which was built in 1904, closed permanently in 1987 because it would have been too costly to rebuild to bring into compliance with air quality standards.

<sup>50</sup> "Public" supplies are those drinking water systems serving 25 or more people, or 15 service connections.

<sup>51</sup> Donald V. Feliciano, "Sole Source Aquifers and Related Congressional Districts," Congressional Research Service, March 1984.

of a facility.<sup>52</sup> Therefore, when considering closure, the potential application of immediate or future hazardous waste regulatory scrutiny must be evaluated.

### Worker **Health and Safety**

Mining activities come under the aegis of the Federal Mine Safety and Health Act of 1977, which regulates on the theory that a safe mine is a productive mine. The Act sets mandatory standards and requires training for new employees plus annual refresher training for all mine workers. The Occupational Safety and Health Act, which covers mills, smelters, and refineries, is similar.

### Other Federal Legislation

In addition to the specific requirements of the Federal and State laws discussed above, a wide

<sup>52</sup>Lester Sotsky, "Closing of a Facility—Legal Concerns," paper presented at American Mining Congress, Annual Mining Convention, San Francisco, CA, 1985.

range of other laws affect the operations of the domestic copper industry. These are listed in table **10-3**. They fall into two main categories: laws that regulate mining activities on public lands, and laws that withdraw public lands from mining. A third group comes into play only when special circumstances arise, such as finding archaeological relics on a mine site, or having protected species located on or near a facility.

### Effects of Environmental Regulation on Competitiveness

In general, the more developed a country is, the more detailed and comprehensive are its environmental controls. In developing countries, any environmental regulation usually is the result of negotiated agreement between the host country and the would-be investor. Increasingly, mining agreements now include various provisions regarding environmental protection. **Although there seems to be a trend toward more stringent environmental controls in LDCs, their**

**Table 10-3.—Other Federal Legislation Affecting Copper Operations**

<b>Public lands</b>	<b>Withdrawals</b>	<b>Other</b>
<p><b>Act of September 28, 1976: Provides</b> for the regulation of exploration and mining within, and repeals the application of mining laws to, the National Park System Forest and Rangeland Resources Planning <b>Act of 1974: Provides for a comprehensive system of land and resource management planning for National Forest System lands</b></p> <p><b>Multiple Use-Sustained Yield Act of 1960: Requires management of National Forests under principles of multiple use so as to produce a sustained yield of products and services</b></p> <p><b>National Forests Management Act of 1976: Provides</b> for a comprehensive system of land and resource management planning for National Forest System lands</p> <p><b>Federal Land Policy and Management Act of 1976: Provides</b> for comprehensive, multidisciplinary land use plans for Bureau of Land Management lands, including multiple use of lands and resources and protection of areas of critical environmental concern</p>	<p><b>Wilderness Act of 1964: Provides</b> for establishment of wilderness reserves; requires preservation of wilderness areas in an unimpaired condition</p> <p><b>Wild and Scenic Rivers Act:</b> Provides for preservation of certain rivers or portions thereof in their natural state</p> <p>National Trails System Act: Provides for establishment and protection of trails</p>	<p><b>Antiquities Act of 1906: Regulates</b> antiquities excavation and collection, including fossil remains</p> <p><b>Archaeological and Historical Preservation Act of 1974: Provides for recovery of data from areas to be affected by Federal actions</b></p> <p><b>Bald Eagle Protection Act of 1969: Protects bald and golden eagles</b></p> <p><b>Endangered Species Act of 1973: Protects endangered and threatened</b> species and critical habitats affected by Federal actions</p>

SOURCE: Office of Technology Assessment, 1988.

**impact on mining is considerably less than in developed countries such as the United States.<sup>53</sup>**

With the exception of air quality control, few data are available on the costs of meeting all environmental and health and safety requirements in the United States. Even fewer data are available on the extent to which foreign operations protect public and worker health and safety or the costs of doing so.

**Such regulation in the United States has brought enormous—but unquantifiable—benefits, from fewer fatal mining accidents, to fewer premature deaths due to air pollution, to cleaner lakes and streams. The costs to the U.S. industry also have been large, with substantial negative impacts on competitiveness and capacity.**

In 1970, when the Clean Air Act first imposed emission limitations on smelters, EPA estimated the total cost of compliance in the entire non-ferrous industry at \$45 million. This grossly underestimated the capital cost of acid plants. Because technological means of control were not yet mandatory, most smelters used supplemental and intermittent SO<sub>2</sub> controls<sup>54</sup> instead, which avoided the large capital costs but reduced production. When technological controls were imposed in 1977, EPA estimated that, if all smelters were assumed to progress toward full compliance by 1988, the total capital cost would be \$1.9 billion for the period 1974-87, with total operating costs of \$1.1 billion (1974 dollars). If, on the other hand, 3 smelters (Douglas, McGill, and Tacoma) were assumed to close in 1983, the EPA estimates of total capital and operating costs for 1974-87 declined slightly to \$1.7 billion and \$1.05 billion, respectively (1974 dollars).<sup>55</sup>

In reality, the primary copper industry had capital investments totalling \$2.1 billion for air pol-

lution control between 1970 and 1981 (in 1981 dollars), with total annual costs of \$3.1 billion over the same period. Estimated capital costs for 1981-1990 are \$387 million, with total annual costs for that decade of **\$3.64 billion** (also 1981 dollars).<sup>56</sup> **Eight copper smelters closed permanently from 1979-86, some because of age or cutbacks in domestic mine production, but some because the cost of installing a new furnace and adding an acid plant was too great.** Additional investments have been made since, and the remaining 8 smelters are in compliance with the Clean Air Act. Present levels of control entail capital and operating costs of between 10 and 15 cents per pound of copper.<sup>57</sup>

In comparison, copper smelters in Canada, Chile, Mexico, Peru, Zaire, and Zambia—among our major foreign competitors—are not faced with similar environmental regulations. If smelters in these countries are controlled at all, it is only to the extent that sulfuric acid is needed for leaching. Thus these countries achieve from 0 to around 15 percent capture of the input sulfur, or about one-fifth of the present level of U.S. control. Japanese smelters achieve 95 percent control as part of government policy to subsidize sulfuric acid production to supply the Japanese chemical industry.<sup>58</sup> Information regarding the costs of acid production in these countries is not available.<sup>59</sup> Future capital investments in Chile, Mexico, Peru, Zaire, Zambia may be funded in part by the World Bank (see ch. 3). The World Bank requires environmental controls as a condition for financing, but the standards are less stringent than those in the Clean Air Act.<sup>60</sup>

Costs also were incurred by the domestic industry because of changes in the emission limitations and allowable means of control, and the deadlines for meeting them. Several smelters installed technologies that seemed promising at the time, but later failed either in producing copper

<sup>53</sup>MacDonnell, *supra* note 7.

<sup>54</sup>Supplemental control systems use very tall stacks to disperse pollutants, thus diluting their ambient concentration. Intermittent control consists of monitoring the ambient weather conditions to identify when wind patterns and temperature inversions could trap the pollutants near the source instead of dispersing the plume. Under these conditions, production is cut back to the point necessary to reduce pollutant emissions to an acceptable ambient concentration.

<sup>55</sup>Arthur D. Little, Inc., *Economic Impact of Environmental Regulations on the United States Copper Industry* (Washington, DC: U.S. Environmental Protection Agency, January 1978).

<sup>56</sup>MacDonnell, *supra* note 7.

<sup>57</sup>Everest Consulting, *Air Pollution Requirements for Copper Smelters in the United States Compared to Chile, Peru, Mexico, Zaire and Zambia*, 1985.

<sup>58</sup>CRU *Copper Studies*, *supra* note 4; see discussion of trade in ch. 4.

<sup>59</sup>MacDonnell, *supra* note 7.

<sup>60</sup>Everest Consulting, *supra* note 57.

OF in controlling emissions (e. g., the Hoboken converter at Inspiration Consolidated Copper Company, and the Arbiter process at Anaconda's Butte smelter). Without major technological advances, further environmental regulation (e.g., the suggested 1-hour sulfur dioxide standard or mine waste management under Subtitle C of RCRA) could bring further reductions in domestic mining and smelting capacity.

Given the health and safety implications of reducing the number of environmental regulatory requirements in the United States, that is an unlikely option. However, introduction of similar requirements in foreign copper-producing countries could "level the playing field" and reduce the impact of domestic regulation on competitiveness. It also would improve the quality of the environment in those countries. **While the United States government has no direct control over foreign environmental regulation, we can have indirect influence through trade and financing, as well as treaties.**

For example, U.S. participation in international financing of foreign copper projects (through the World Bank and its affiliate banks) could be used to apply pressure for environmental controls. One example would be to provide incentives through variable interest rates tied to the degree of control. Tariffs on imported copper also could be tied to the degree of control in the country of origin, although at present there are too few data to make this workable.

Treaties related to border issues also can influence foreign control. The difference in level of control is one issue in the U.S.-Canada Free Trade Agreement. The United States and Mexico signed an agreement January 29, 1987, to control air pollution caused by copper smelters along their common border. Under the agreement, Mexico guaranteed that, by June 1988, SO<sub>2</sub> emissions at the Nacozari smelter will not exceed 0.065 percent by volume during any 6-hour period. This is identical to the U.S. standard for new sources. In the interim, ambient SO<sub>2</sub> concentration levels will not exceed 0.13 parts per million over a 24 hour period (the U.S. standard is 0.14 ppm).<sup>61</sup>

<sup>61</sup> "U. S., Mexico Agree to Control Pollution from Copper Smelters Near Common Border," *Environment Reporter*, vol. 17, No. 42, Feb. 13, 1987, p. 1738.

## Research and Development

**Research and development could result in process and product technologies that would significantly improve the competitive position of the domestic copper industry.** Technological innovations developed and implemented within the last 10 years helped the industry reduce their costs of production and increase productivity. Additional R&D, especially in areas where the United States is at a competitive disadvantage or has unique resource endowments, could provide further boosts to competitiveness. For example, domestic mines haul larger amounts of ore greater distances, making improvements in haulage productivity especially advantageous in the United States. Similarly, in situ solution mining would enable U.S. companies to exploit large oxide ore resources without having to haul the ore. This section reviews Federal R&D funding mechanisms; private initiatives are discussed below.

**There is no comprehensive Federal policy toward R&D.** Legislation intended to further specific policy goals may authorize expenditures for R&D (although actual appropriations may fall short of the authorization). For example, the National Materials and Minerals Policy, Research and Development Act of 1980<sup>62</sup> was intended to provide a basic coordinating framework for executive branch materials policy decisions. The Act encompasses all materials related to industrial, military, and essential civilian needs. It emphasizes, however, strategic materials for which the United States is heavily import-dependent but could augment supplies through substitution, recycling, and conservation. The Act also emphasizes the importance of government support for R&D in addressing materials problems.

The Act required the President to formulate a materials and minerals program plan. President Reagan submitted this plan to Congress in April 1982. His report focused primarily on minerals availability issues associated with Federal lands and on management of the stockpile; it placed little emphasis on R&D. The plan assigned responsibility for coordination of national materials policy to the Cabinet Council on Natural Resources

<sup>62</sup>P. L. 96-479.

and the Environment. Coordination of R&D not involving policy questions was assigned to the Interagency Committee on Materials (COMAT), under the direction of the White House Office of Science and Technology Policy.

Although President Reagan's plan has been criticized heavily both in concept and implementation,<sup>63</sup> strategic materials R&D funding has fared fairly well. In addition, initiatives have been undertaken that were not specifically identified in the plan, such as creation of a National Strategic Materials and Minerals Program Advisory Committee within the Department of the Interior.<sup>64</sup>

R&D funding for minerals and materials also may be provided as part of an agency's overall program responsibilities. For copper production and related technologies, this would include primarily R&D sponsored by (and often actually carried out by) the Bureau of Mines and Geological Survey, both within the U.S. Department of the Interior (see table 10-4).

The Bureau of Mines conducts basic and applied research on all types of minerals to improve understanding of the principles of mining and mineral processing and to reduce associated health hazards. Their R&D budget for FY 89 is expected to decrease by \$10 million to \$86 million.<sup>65</sup> The proposed decrease was in applied research, which the Reagan Administration believes is the responsibility of private industry.<sup>66</sup>

The Geological Survey undertakes research on the extent, distribution, and character of mineral and water resources; on geologic processes and principles; and on the development and application of new technologies, including remote sensing, for mapping. Their total R&D budget for

FY 89 is projected to be \$224 million, a decrease of \$12 million from FY 88.<sup>67</sup>

Some Federal (and private) R&D money goes to support research programs at universities, including the State mineral institutes and the Bureau of Mines mineral technology centers. The mineral institutes originally were administered by the Office of Surface Mining; responsibility subsequently was transferred to the Bureau of Mines. Proposals to abolish the institutes have been included in almost every budget request since 1982. Special legislative initiatives also have provided for research centers, such as the 1-year grant for the new Center for Advanced Studies in Copper Research and Utilization at the University of Arizona, whose mandate focuses primarily on copper product applications (such as superconductors), but also includes research on process technologies (e.g., in situ solution mining).

**Research funding for universities not only provides a valuable source of technological innovation for the minerals industry, but also supports education and training for the next generation of industry employees.** Enrollment in mining and other engineering disciplines historically has been cyclical, and currently is low due to the poor economic performance of the minerals industry during the early 1980s. In 1978, 3,117 undergraduate students were enrolled in 26 mining engineering programs in the United States. By 1987, the number of programs had dropped to 19, with additional closings and mergers expected. As a result, significant shortages of mining engineers are predicted at least through 1992.<sup>68</sup> Evidence of Federal support for truly innovative R&D could salvage some university programs and attract high quality students.

More specialized research on applications for copper is funded by the National Bureau of Standards (e.g., specialty alloys) and the Department of Energy (for example, materials for transmission lines or solar energy systems). The National Aeronautics and Space Administration also funds some research on remote sensing that could be applicable to mineral exploration. The

<sup>63</sup>See, e.g., U.S. General Accounting Office, *Implementation of the National Minerals and Materials Policy Needs Better Coordination and Focus* (Washington, DC: U.S. General Accounting Office, Mar. 20, 1984), GAO/RCED-84-63.

<sup>64</sup>OTA, *supra* note 40.

<sup>65</sup>The total Federal expenditures for R&D in 1986 were \$14 billion. Although the United States spends more on R&D than any other country, it continues to lag behind some of its competitors in the share of gross national product devoted to civilian R&D. While Japan spends nearly 3 percent of its GNP on R&D, the U.S. share is only slightly above 2.5 percent. see "R&D Scoreboard," *BusinessWeek*, June 22, 1987.

<sup>66</sup>Office of Management and Budget, *Special Analyses: Budget of the United States Government, Fiscal Year 1989* (Washington, DC: U.S. Government Printing Office, 1988).

<sup>67</sup>*Ibid.*

<sup>68</sup>Eileen Ashworth, "Where Have All the Graduates Gone," *LANDMARC*, January/February 1988.

**Table 10-4.— Federal R&D Expenditures Related to Mineral Resources and Production (1,000 current dollars)**

Year and budget category	Bureau of Mines	Percent of total	USGS	Percent of total	Year and budget category	Bureau of Mines	Percent of total	USGS	Percent of total
1974, <i>total budget:</i>	\$81,689		\$172,324		1983, <i>total budget:</i>	\$144,568		\$371,784	
Geological and mineral resource surveys and mapping			43,340	25%	Geological and mineral resource surveys and mapping			159,096	42%
Metallurgical research	15,779	19%			Minerals and materials research	29,680	21%		
Mining research <sup>a</sup>	39,267	48			Mineral institutes	9,152	6		
1975, <i>total budget:</i>	148,820		254,146		1984, <i>total budget:</i>	136,855		377,672	
Geological and mineral resource surveys and mapping			76,268	30	Geological and mineral resource surveys and mapping			164,289	43
Metallurgical research	17,995	12			Minerals and materials research	32,754	24		
Mining research <sup>a</sup>	50,437	34			Mineral institutes	9,350	7		
1976, <i>total budget:</i>	158,818		272,836		1985, <i>total budget:</i>	135,959		416,368	
Geological and mineral resource surveys and mapping			102,203	37	Geological and mineral resource surveys and mapping			169,595	40
Metallurgical research	21,744	14			Minerals and materials research	31,944	23		
Mining research <sup>a</sup>	87,279	55			Mineral institutes	7,822	6		
1977, <i>total budget:</i>	133,611		320,433		1986, <i>total budget:</i>	127,711		412,306	
Geological and mineral resource surveys and mapping			96,870	30	Geological and mineral resource surveys and mapping			169,356	41
Metallurgical research	22,593	17			Minerals and materials technology	30,692	24		
Mining research <sup>a</sup>	33,329	25			Mining technology	12,808	10		
1978, <i>total budget:</i>	138,200		375,899		Mineral institutes	7,677	6		
Geological and mineral resource surveys and mapping			112,708	29	1987, <i>total budget:</i>	140,412		431,193	
Metallurgical research	25,023	18			Geological and mineral resource surveys and mapping			168,656	39
Mining research <sup>a</sup>	46,431	34			Minerals and materials technology	32,208	23		
1979, <i>total budget:</i>	148,476		418,519		Mining technology <sup>b</sup>	18,598	13		
Geological and mineral resource surveys and mapping			131,640	31	Mineral institutes	7,642	5		
Mineral resources and technology	33,680				1988, <i>total budget:</i> <sup>c</sup>	146,398		447,997	
1980, <i>total budget:</i> <sup>d</sup>	134,033		469,862		Geological and mineral resource surveys and mapping			176,430	39
Geological and mineral resource surveys and mapping			143,039	30	Health, safety and mining technology	53,167	36		
Mineral resources and technology	29,727	22			Minerals and materials science	27,092	19		
1981, <i>total budget:</i>	142,319		516,056		Mineral institutes	9,160	6		
Geological and mineral resource surveys and mapping			160,027	31	1989, <i>total budget:</i> <sup>e</sup>	126,605		425,253	
Mineral resources and technology	24,883	17			Geological and mineral resource surveys and mapping			167,767	39
1982, <i>total budget:</i>	150,602		507,846		Health, safety and mining technology	37,735	30		
Geological and mineral resource surveys and mapping			163,706	32	Minerals and materials science	23,440	19		
Minerals and materials research	32,003	21			Mineral institutes	0	0		
Mineral institutes	9,244	6							

aIncludes research related to environment and health and safety.

bAll 1988 and 1989 figures are estimates.

SOURCE: Office of Management and Budget, *Budget of the United States Government* (Washington, DC: US Government Printing Office, various years)

**U.S.** Environmental Protection Agency is responsible for R&D on pollution control technologies. Finally, the Department of Defense conducts research on materials for ordnance, weapons systems, etc.

Federal tax policy also can affect private funding for R&D, e.g., by providing tax deductions for credits for R&D expenditures or for demonstration projects featuring unproven technology. Unless "R&D" is defined very narrowly, how-

ever, industry can interpret it broadly with corresponding high revenue losses.

## Industrial Policy

"industrial policy" was the political philosopher's bromide of the early 1980s, as "competitiveness" has become the catchword for the mid-80s. Development of a coherent and consistent Federal policy toward industry, and then toward

improving domestic industrial competitiveness, was widely touted as the solution to industrial ills. Such an integrated policy scheme is still absent in the United States.

Instead, current Federal competitiveness policy is to rely primarily on private initiatives and the market. When the importance of a particular industry (e.g., for national security) or the extraordinary scope of market changes seems to merit public intervention, there are few policy instruments for actively promoting domestic competitiveness. Instead, government actions have focused on trade protection, including Orderly Marketing Agreements (bilateral agreements to restrict imports into the United States), ad hoc agreements, and tariffs.

**Protectionist policies insulate American producers from incentives to adjust to foreign competition. They also can distort markets in ways that require increasing protection.** For instance, although Orderly Marketing Agreements usually are intended to give American firms time to adjust to changing market conditions, the restrictions on imports from one country can encourage new producers in other places. Moreover, limiting the volume of imports can induce U.S. fabricators to shift to other materials, and foreign producers to shift to higher-value goods to preserve their foreign exchange.<sup>69</sup>

Other policies that introduce market distortions include direct or indirect subsidies, and dumping (selling exports at prices less than charged in domestic markets, or at less than cost). Policies of promotion and subsidy pursued by LDCs are a particular problem. While they may reduce the cost of goods to domestic consumers, they also disadvantage domestic producers. In addition, as discussed in chapter 4, the Japanese smelting industry receives direct and indirect subsidies to promote sulfuric acid production. The Canadian smelters also receive government assistance in financing pollution control. Of course, domestic companies also have obtained direct subsidies (see box 10-A, below).

**Although the domestic copper industry survived the economic vagaries of the early 1980s**

<sup>69</sup>Zysman and Tyson, *supra* note 3.

**without significant government assistance, they lost a lot of money and capacity in the process. Their ability to survive a similar slump within the next 5-10 years could depend on government support now to actively promote domestic competitiveness. One of the keys to continuing competitiveness is the ability to innovate, which** in turn is dependent on capital formation, or investment in plants and equipment embodying new, more efficient technologies; education and job training programs; and the development of new commercial products and processes.<sup>70</sup>

Thus, **policy support for continuing competitiveness would have to include both micro- and macroeconomic policies.** The former includes anti-trust, trade, defense, patent, tax, job training and education, environmental protection, and R&D policies. These are considered macroeconomic because each policy directly or indirectly affects ability of companies to compete with foreign-based companies in domestic and key export markets). The second group covers fiscal and monetary policies. Fiscal policy is important because it establishes the level of overall output, inflation, and employment; and because government borrowing to finance deficits influences interest rates, both for industry itself, and for primary and secondary consumers.<sup>71</sup>

**A consistent and integrated set of government policies can gradually turn a temporary comparative disadvantage in capital- or education-intensive commodities into an advantage.** Seen in this light, the growing comparative advantage of Japan<sup>72</sup> and the declining share of U.S. producers result to no small degree from different national investment efforts influenced by different government policies.

Although a well-designed and supportive industrial policy is not by itself sufficient to build competitiveness in a given economic sector, government policies may tip the balance. The United States can expect no more than very limited success in negotiations with other nations aimed at minimizing the impacts of those countries' indus-

<sup>70</sup>Guenther *supra* note 2

<sup>71</sup>*Ibid*

<sup>72</sup>Japanese government policies toward development of the iron smelting industry are described in the section on Trade in ch 4.



trial policies. Better prospects for strengthening the U.S. position would come with the adoption of more effective industrial policies of our own.

**A third option is to provide direct product support.** This might include increased use of domestic copper in coinage, or mandated use of domestic copper products in governmental activities (e.g., plumbing and wiring in Federal build-

ings). Coinage reform has been proposed for several years, including increased copper content of the penny (which is currently 95 percent zinc—mostly imported) and a copper dollar coin. **While such measures may be small potatoes in terms of overall copper demand, they are symbolically important in demonstrating Congressional support for domestic products.**

## INDUSTRY STRATEGIES AFFECTING COMPETITIVENESS

**Domestic copper companies undertook a number of initiatives from 1980-1987 in order to reduce their costs of production and improve their competitive position.** These are summarized in table 10-5. Aside from direct cost reductions such as those obtained in the labor negotiations of 1986, these actions can be grouped in three rough categories—actions that resulted in significant corporate restructuring, those that required capital investment, and those that reduced production and/or capacity. Two companies also received significant local government support and renegotiated labor and service contracts in order to re-open mines (see box 10-A).

**Most companies invested in new technology** for mines, mills, smelters, and refineries, or added low-cost SX-EW capacity. For example, automated controls at all stages of copper production provide increased operating efficiency and are now installed at almost all operations. Those companies that had not yet modernized their smelters and/or furnaces did so. In addition, at least one operation—Kennecott—underwent major mine modification, including the addition of in-pit crushing and conveying equipment. PD also converted its Morenci mine from rail to truck haulage and plans to install in-pit crushing and conveying.

**A few companies actually expanded their operations** by either purchasing developed copper properties, or increasing the capacity of their existing mines or processing facilities. Copper Range improved mine and mill efficiency and thereby substantially increased throughput. For Asarco and PD, expansion was part of a strategy to improve the balance between mining and processing capacity. In Asarco's case, such a strat-

egy was needed because they historically were not a mining company and wished to acquire a secure supply of feed for their smelters. For PD, a mine acquisition replaced mining capacity shut down or soon to be depleted. Cyprus also bought significant new capacity, in part to fill out their operations after they were spun off by Amoco Minerals, and in part to replace properties that were closed during this period.

**Other companies cut back production** in response to the decreased demand and increased imports of the early to mid-1980s. Partial capacity utilization is a sub-optimal policy for many mines, however. Full closure may be more advantageous if the closure costs are less than the mine's anticipated operating losses during the period of depressed prices.<sup>73</sup>

**Several firms either sold or spun off all of their copper operations, and are no longer in the copper business in the United States.** After purchasing Cyprus Mines in 1979, Amoco Minerals spun off this subsidiary to the shareholders in 1985. Similarly, Newmont Mining spun off 80 percent of Magma Copper (including Pinto Valley) in 1986. Newmont still owns shares in foreign copper properties. Arco/Anaconda, Cities Service, and Louisiana Land sold or closed permanently and wrote off all of their domestic copper operations.<sup>74</sup>

<sup>73</sup>Evans, *supra* note 10.

<sup>74</sup>Louisiana Land sold the Copper Range refinery to Echo Bay, which plans to sell it to Northern Copper Co. (operating as Copper Range) within the next couple of years.

**Table 10-5.—Strategies Adopted by U.S. Copper Companies in Response to Economic Conditions, 1980-87**

Strategy	Amoco Minerals <sup>a</sup>	ATCO/Anaconda <sup>b</sup>	Asarco	Cities Service <sup>c</sup>	Copper Range	Cyprus	Louisiana Land <sup>d</sup>	Insoiration <sup>e</sup>	Kennecott <sup>f</sup>	Macoma	Montana Resources	Newmont <sup>g</sup>	Phelps Dodge
<b>Strategies to cut losses (or raise capital):</b>													
Sold copper properties (or shares)	X											x	X
Spun off properties to new company	X											x	
Closed mine(s) for foreseeable future	X	x	x									x	X
Closed mine(s) temporarily or cut production		X	x					x				x	
Closed smelter(s) permanently		x	x						x				X
Closed smelter temporarily									x				
Toll smelting only													
Closed refinery permanently													X
Closed refinery temporarily		x											
Sold non-copper properties													X
Diversified													X
No longer in U.S. copper business	X	x		x									
<b>Strategies to improve competitive position:</b>													
Bought developed copper properties			x		x							x	
Opened new mine(s)			x						X				
Expanded production at existing mine(s)			x										
Major mine modernization	X		x										
Other new mining technology			x										
Mill modernization			x										
Added SX-EW capacity													
Replaced smelter furnace													
Other smelter modernization													
Refinery modernization													
Built new refinery													
Improved balance between mining/processing													
Obtained State/local govt. assistance													
Renegotiated labor costs													
New labor contract													

<sup>a</sup>Copper properties spun off to Cyprus Minerals in 1980.

<sup>b</sup>Closed all properties; Butte, Montana operations sold to Montana Resources in 1985.

<sup>c</sup>Owned Duval; most properties sold or leased to Cyprus since 1985.

<sup>d</sup>Sold to Echo Bay Co. before Northern Copper was formed to own/operate the White Pine mine.

<sup>e</sup>Sold to Cyprus in June 1988.

<sup>f</sup>Sold Ray Mines to Asarco in 1986 and Chino Mines to Phelps Dodge in 1986.

<sup>g</sup>Spun off Magma (including Pinto Valley) as separate company in 1986, but retained a 15 percent interest.

SOURCE: Office of Technology Assessment.

### Box 10-A.—State and Local Assistance and Cost Concessions Obtained by Montana Resources and Copper Range

In 1985, Washington Construction, a Montana-based firm, purchased the assets of Anaconda's Butte operations for \$7 million intending to salvage them for scrap. After conferring with Anaconda's former general manager, however, Washington Construction determined that the mine and mill could reopen profitably. The State and local governments, eager to see the operation contributing to the economy once again, quickly granted the necessary permits. The State also procured a \$12 million line of credit to underwrite startup costs. The county granted an \$8 million tax cut. The company obtained a 12 cent/lb reduction in the transportation and refining costs Anaconda had paid to ship the concentrate by rail to California and have it processed in Japan. The local power company granted lower rates for electricity. Finally, the number of workers was cut almost 50 percent, and the top wage went from \$22/hr to \$13/hr. As a result, when the East Berkeley Pit reopened early in 1986 as Montana Resources, Inc., it was reportedly mining copper for 58 cents/lb, compared to Anaconda's 97 cents/lb.<sup>1</sup>

Louisiana Land purchased Copper Range (the White Pine, Michigan mine) in 1977, but closed the high-cost underground operation in 1982 to cut losses. In 1984, Echo Bay acquired most of the assets of Copper Range as part of the purchase of a Nevada gold mine. A year later, Northern Copper—a newly-formed firm consisting primarily of former White Pine managers and employees—bought the mine and smelter for \$32 million. The financing was arranged by Solomon Brothers. The State of Michigan provided a \$4.5 million loan and about \$3 million in training and grants. Before the mine reopened, a new labor contract was negotiated that brought total labor costs to below \$12/hr, about \$3/hr less than at other union mines.<sup>2</sup>

<sup>1</sup> "There's a Gleam in the Eye of Copper Producer," *Business Week* 1986

<sup>2</sup> "US Industry Responds to Dramatic Change in World Role," *CRU Copper Studies*, vol. 14, No. 4, Oct. 1986

## Future Industry Options

As a result of actions taken during the early to mid-1980s, the domestic copper industry is now competitive in world markets, although at the cost of production capacity and market share. However, next time the price drops—whether due to a recession or new producers creating an oversupply—it is likely to go lower than it did in 1984 (perhaps as low as 40 cents/lb), and stay low longer. To be competitive at that price, domestic producers will need entirely new process technologies (e. g., in situ solution mining) or a captured market. This will require investments in R&D now, as well as new ways of thinking about their product.

**Research and Development.—Direct R&D spending in the primary copper industry is low, averaging less than 1 percent of sales in 1986.**<sup>75</sup>

This compares to an overall average for the metals and mining industry of almost 2 percent of sales (see table 10-6), and a national industrial average of 3.5 percent of sales. <sup>76</sup> The mining in-

<sup>75</sup>If exploration expenditures were included, this fraction would be higher.

<sup>76</sup>*Business Week*, supra note 65.

**Table 10-6.—1986 R&D Expenditures in Selected Industrial Sectors**

Sector	R&D expenditures as a percent of sales
Aerospace	4.5%
A u t o m o t i v e	3.7
Chemicals	4.1
Drugs	7.8
E l e c t r i c a l	3.3
E l e c t r o n i c s	4.4
Fuel	0.8
Information Processing—Computers ...	8.3
Information Processing—Software	7.7
Instruments and Controls	6.7
Machinery—Industrial and Mining	3.3
Metals and Mining	1.8
Semiconductors	12.2
S t e e l	0.5
Telecommunications	5.1
T e x t i l e s	0.8

SOURCE "R&D Scoreboard," *Business Week*, June 22, 1987.

dustry considers exploration to be research, and traditionally has sought better deposits rather than better technology. Members of the copper industry argue that most innovations are developed by equipment vendors, yet the Industrial and Mining Machinery sector also lags behind the national average in R&D expenditures. Further, the U.S. mining machinery industry has consistently lost market share to foreign competitors throughout the 1980s, and currently is operating with substantial excess capacity.<sup>77</sup> If this trend **continues, their R&D expenditures can be expected to decline.** Further shifts of R&D to overseas also will shift the research's focus to solving foreign problems.

**One option for increasing the level of R&D on production technology is for the domestic copper industry to actively pursue cooperative research ventures involving copper companies, vendors, universities, and government agencies.** Anti-trust and patent concerns about such ventures were addressed in the National Cooperative Research Act of 1984 (P. L. 98-462). In the past, cooperative research has been limited to vendors or the Bureau of Mines borrowing plant space for small but time-consuming development and demonstration projects—often the most expensive aspect of R&D. Within the last year, all these groups have begun to explore avenues for cooperative research in an organized way. One concern is the continuity of funding from all parties once a project is underway.

**New Copper Products.—The domestic copper industry is still faced with competition for markets, both from foreign imports and from other metals and materials (e.g., aluminum). If they want to offset further market losses, two basic options are available—expand sales in current markets or develop new products and uses for copper and market them aggressively.**

The companies argue that marketing for expansion would be futile because they already are sell-

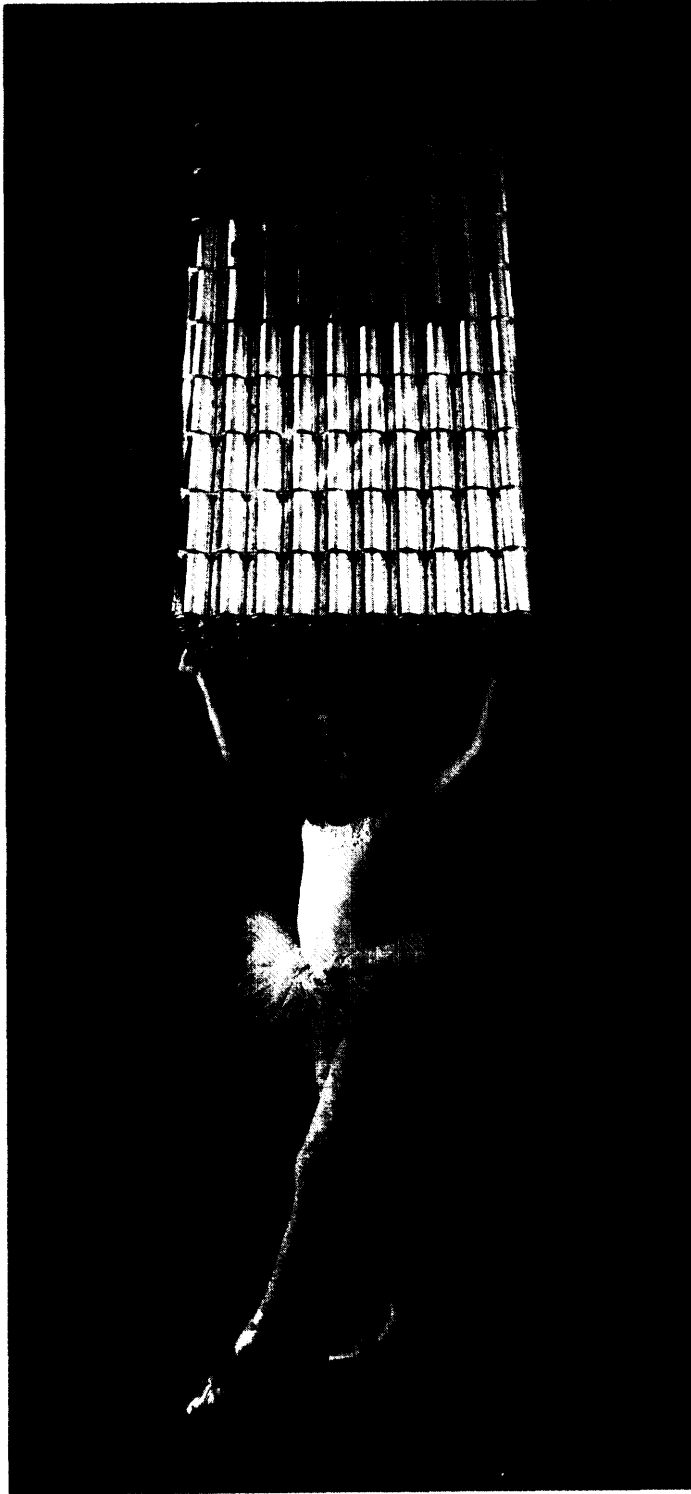
ing all the copper they produce. In the same breath, they complain about idle capacity and low prices due to excess supplies. Simultaneously developing new markets and capturing a larger share of them could address both problems.

**One key to expanding sales is marketing based on product differentiation.** Superior quality may command higher prices in the marketplace, making production costs less significant.<sup>78</sup> Although, copper traditionally has been considered a non-differentiable commodity of uniform quality, at least one domestic company prides itself on the quality of its final product—copper rod. That company brags that its final metallurgical testing is good enough to produce a zero rate of rejects during wire manufacture. indeed, if a wire customer complains about breakage or other failures, the company sends consultants to visit the wire plant to trace the source of the problem there. Yet this company advertises neither the superior quality of its product nor its backup services. product differentiation based on quality is likely to become more important as specialty copper alloys and high-technology applications such as superconducting materials occupy an increasing share of the end-use market.

Similarly, copper has properties that make it superior to the materials that often are substituted for it. When faced with direct market threats (e.g., aluminum wiring in houses), copper industry associations have publicized the disadvantages of the substitute material. Yet neither individual companies nor their associations regularly advertise copper as part of a consistent strategy of market development. In contrast, one of copper's major competitors—the aluminum industry—regularly advertises both its product and its innovative research programs in the trade press.

<sup>77</sup>ITA, *supra* note 8.

<sup>78</sup>Note also the difference in table 10-6 for R&D expenses for the two extractive industries (fuel and metals/mining), which see little opportunity for product differentiation, versus the remaining manufacturing and processing industries, which can profit from differentiation.



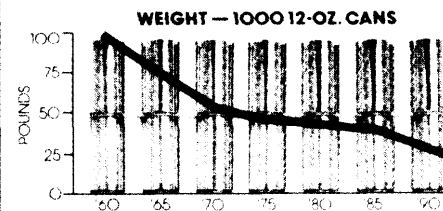
## Where Muriel Gets Her Muscle

**M**ighty Muriel can lift 1,000 aluminum beverage can bodies.

No mirrors. No invisible wires. It's all done with a series of technological breakthroughs that have thinned the walls of the latest can bodies down to 0038."

Early beverage cans were steel, 1000 empties weighed over 100 pounds. By 1975, new aluminum alloys had reduced the load to 43.5 pounds. And today?

What Muriel is demonstrating is brains, not brawn. It's now practical to get 1,000 bodies out of 25 pounds of metal—because Alcoa scientists developed remarkably tough alloys for rigid container sheet, the automated processing to keep thin sheet consistent in properties and gauge, and a whole family of new lubricants to adapt these ultra-thin gauges to high-speed processing by canmakers and beverage companies.



*And now, for an encore...*

These same advances plus a few more have made aluminum competitive not only for beverage cans but for food cans as well. And we've been working on new laminates, composites, and polymers that will figure prominently in the coming age of aseptic and high-barrier food packaging.

We're out to make a material difference, and our progress is accelerating.

For a closer look at what's happening at Alcoa Laboratories, send for our book, *The Material Difference*.

Write to Dr. Peter R. Bridenbaugh, Vice President—Research & Development, Box One, Alcoa Laboratories, Alcoa Center, PA 15069.



*Photo credit: Engineering and Mining Journal*

An aluminum company advertisement highlighting product research.

Another aspect of product differentiation through marketing is based on the advantages of purchasing from domestic producers. For example, orders can be filled more quickly. **In the past, fabricators and manufacturers** often held large stockpiles as hedges against price increases and/or supply shortfalls. In today's tight economy, this can be disadvantageous to cash flow. Many consumers already have changed their purchasing policy to smaller stockpiles; using domestic supplies facilitates this policy. Reliance on domestically-produced copper also would make return and replacement of defective products simpler.

Finally, a "Buy American" campaign backed up with ads about the problems faced by the domestic copper industry could be very effective—especially if aimed toward the effects of imports on domestic capacity and employment. Purchasing foreign products and components means not only losses of present domestic employment and

market share, but also the advancement of foreign manufacturing expertise and thus future market share. This includes larger volumes over which to spread manufacturing, tooling, and R&D costs; an accelerated learning curve; and expanded opportunities for innovation, and process development and demonstration. 'g

**R&D for developing new products and uses for copper shares a common problem with research on mining and processing technologies—the primary copper industry assumes the consumers (including the government) will take the initiative.** Associations representing the primary copper industry regularly publicize promising new applications, but do little direct research. Yet other metals in decline have found cooperative R&D with major consumers on new products very promising. Box 10-B presents an example from the steel industry.

<sup>1</sup>K. K. Kappmeyer, "Steel/Auto Partnership: A Blueprint for Competitive Advantage," *Materials and Society*, vol.11, No. 2, 1987.

#### Box 10-B.—Cooperative Steel/Auto Industry Research<sup>1</sup>

In the early 1980s, the steel industry began to take an active role in dealing with trends related to substitution of materials, and foreign capture of markets, for steel parts in the automotive industry. This began as a defensive move and gradually shifted to aggressive action to create a domestic competitive advantage.

The American Iron and Steel Institute (AISI), the trade association for the North American steel industry, has an Automotive Applications Committee that sets priorities for, and commissions original research on, the use of steel in the automotive industry. It also educates the U.S. automotive industry about the effects of materials substitution on domestic competitiveness (i.e., the Japanese auto industry is more competitive with steel parts than the domestic industry is with plastics and composites).

Recognizing that the competitive futures of the American steel and auto industries are intertwined, the steel industry began seeking solutions that would help both. An early initiative was seminars for steel industry executives; the speakers were advanced product engineers in the auto industry. The aim was to discuss differences between what the steel industry was producing (under 30-year old process and product standards) compared with what the auto industry needed.

The seminars resulted in three major projects: 1) a design manual prepared by a task force of 9 steel company representatives, 13 auto company advisors, and a wide variety of outside consultants in, e.g., welding and computerized structural design; 2) a commissioned study of the relative tooling costs for steel and plastics to determine what influences steel tooling costs and to initiate steps to lower them; and 3) analyses of gauge specifications, materials characteristics and uniformity, and manufacturing costs and their relationships to product uniformity, intended to reduce auto manufacturing costs.

In addition, this steel/auto partnership established a University Steel Resource Center at Northwestern University. The Center aims to bring steel producers and consumers together to work on common technical and institutional issues. AISI provides direct funding; Northwestern obtains State and local support.

<sup>1</sup> K. K. Kappmeyer, "Steel/Auto Partnership: A Blueprint for Competitive Advantage," *Materials and Society*, vol. 11, no. 2, 1987.

The chief advantages of the strategies described in box 10-B are knowing the needs of the consumers and being able to find ways of serving those needs with copper rather than alternative materials. Attempts to ascertain customer needs also create a positive external image that would be useful in designing marketing and promotion policies.

One difference between the steel industry example and the copper industry is that very exacting standards for particular uses of copper have existed for some time (e.g., electrolytic copper, oxygen-free copper; see ch. 6). However, steel industry studies will produce analyses of "as received" variability, which could support marketing based on product quality. In the copper industry, similar analyses could examine the extent to which delivered products met established standards (e.g. based on percentage of product returns for failures during fabrication or manufacturing), and therefore consumer costs associated with such failures.

A second approach to giving more attention to demand is modeled on the aluminum industry's strategy. Trends in aluminum originally were similar to those in copper. Aluminum production expanded into a global business, and the U.S. share of world capacity dropped. Although most ore had always come from overseas mines, they were controlled by U.S. firms. Then many foreign mines were nationalized, and a growing percentage of new capacity is government-controlled. The LME and COMEX began trading aluminum ingot, and prices became volatile. Scrap emerged as a growing source of supply. Expanding foreign trade meant the United States became a net importer of ingot and increasingly of semi-fabricated aluminum products. Profits dropped and some companies went out of the aluminum business. Others pursued strategies to ensure their positions as viable aluminum producers with long-term profitable growth. These strategies were much the same as those followed by copper producers (plant modernizations, renegotiated contracts, etc. ) with one major exception—the aluminum industry expanded into more value added aluminum products and related businesses (see box 10-C).

#### Box 10-C.—Forward Integration in the Aluminum Industry<sup>1</sup>

**To maintain profitability, many of the major aluminum companies have undertaken strategies of forward integration into value added products and/or diversification into non-aluminum (but mostly materials-related) businesses.**

Alcoa has done both simultaneously. In the value added products area, Alcoa is now producing aluminum memory disks for the computer industry instead of just aluminum blanks. Alcoa hopes to have 25 percent of sales from non-aluminum products by 1990, up from 10 percent in 1984. They have acquired a defense materials research company, and are applying what they know about aluminum to other materials to aid in ventures in structural ceramics, chemical separations, and polymer packaging.

Reynolds is continuing to pursue fabricated and value added aluminum products. They introduced a new line of aluminum can sizes plus a new nitrogen technology for packaging. Also, combining aluminum and plastic, Reynolds has developed a lightweight meal pouch for military use.

Kaiser already was very diverse, including oil and gas ventures, and real estate. They have now forward-integrated into aluminum memory disks.

Alcan entered the U.S. market by purchasing Arco's aluminum assets. They are developing the new business through new projects, joint ventures, and acquisitions in the areas of aerospace, packaging materials, electronics, and communications and transportation markets.

<sup>1</sup>Joseph J. Tribendis, "The U.S. Aluminum Industry: Into Its Second Century," *Materials and Society*, vol. 10, no. 2, 1986.

A significant difference between the two industries is that copper historically has experienced demand growth from electricity and communications. Thus investment strategies focused on production rather than consumption. As the number of copper producers grew, the companies dis-integrated vertically. The technologies associated with fabrication and manufacture of copper products became standardized, which led to numerous independent fabricators.

In the aluminum industry, in contrast, early high prices limited use and cheaper and more abundant metals captured markets. When the aluminum price did come down with the invention of electrolytic processing, the major companies adopted aggressive market expansion as their central policy. They integrated vertically toward production of consumer products, created new applications through R&D, and undertook an intensive campaign to publicize and promote the advantages of their products. This strategy made it possible to charge lower prices for products competing with those manufactured from copper, steel, brass, pewter, or glass, and thus capture a significant share of those markets.<sup>80</sup>

**Aluminum's success highlights the advantages of integrating operations forward to create demand.** Yet during the copper industry's recent restructuring, significant further dis-integration occurred. Although most major U.S. copper

refineries also produce continuously cast rod, most ties between copper mines and wire and brass mills have been severed. Historically, these ties were valuable to ensure low-cost, secure supplies of copper. With the changes in pricing, and the increased supply of foreign copper and scrap, however, the traditional reasons for strong ties between mining and fabrication have disappeared. For example, in 1980, PD had 15 mills and plants producing tube, brass and bronze alloy products, cable wire rod, and other manufactured products. As part of their asset restructuring program, PD has since sold all of their downstream fabricating and wire business except magnet wire.

Essentially, the copper producers consider vertical integration to be competing with their customers. Demand growth is no longer rapid, however, and coupling forward integration with the development of new products and uses could be effective in helping the domestic copper industry retain their market share.

<sup>80</sup>Jose Luis Mardones et al, "The Copper and Aluminum Industries: A Review of Structural Changes," *Resources Policy*, March 1985,



---

# Appendixes

# Acronyms and Abbreviations

ACRS	—accelerated cost-recovery system	IFI	—international financial institution
AD	—antidumping	IMF	—International Monetary Fund
AIDS	—acquired immune deficiency syndrome	IRR	—internal rate of return
AZ	—Arizona	ITA	—International Trade Administration
BC	—British Columbia	ITC	—International Trade Commission
BH:EM&R	—Brook Hunt cost data published by the Canadian Department of Energy, Mines, and Resources	kt	—thousand metric tonnes
BH:WB	—Brook Hunt cost data published by the World Bank	ktpy	—thousand metric tonnes per year
BP	—British Petroleum	kWh	—kilowatt-hour
Btu	—British thermal unit	l	—liter
BuMines	—U.S. Bureau of Mines	lb	—pound
CBO	—Congressional Budget Office	LDC	—less developed country
C <sup>1</sup>	—command-communication-control-intelligence systems	LME	—London Metal Exchange
CDA	—Copper Development Association	MEC	—market economy country
CFF	—Compensatory Financing Facility		—milligrams
CIPEC	—Intergovernmental Council of Copper Exporting Countries	MI	—Michigan
cm	—centimeter	mt	—metric tonnes
CODELCO	—Corporación Nacional del Cobre de Chile	MT	—Montana
COMAT	—Committee on Materials	mtpy	—metric tonnes per year
COMEX	—Commodity Exchange of New York	NA	—not available or not applicable
CRS	—Congressional Research Service	NAAQS	—National Ambient Air Quality Standards
<b>Cu<sub>2</sub>S</b>	— <b>chalcocite</b>	NCCM	—Nchanga Consolidated Copper Mines, Ltd.
<b>Cu</b>	— <b>copper</b>	NEPA	—National Environmental Policy Act
CVD	—countervailing duty	NFMPC	—Non-Ferrous Metals Producers Committee
DC/DA	—double contact/double absorption	NM	—New Mexico
DMA	—dimethylaniline	NPDES	—National Pollution Discharge Elimination System
DPA	—Defense Production Act	NSW	—Non-Socialist World
E&MJ	— <b>Engineering and Mining Journal</b>	NV	—Nevada
EEC	—European Economic Community	NYPP	—New York producer price
EIS	—environmental impact statement	OP	—open-pit
ENAMI	—Empresa Nacional de Minería	OTA	—Office of Technology Assessment
EPA	—Environmental Protection Agency	PD	—Phelps Dodge
Fe	—iron	PNG	—Papua New Guinea
FGD	—flue gas desulfurization	R&D	—research and development
FTA	—U.S.-Canada Free Trade Agreement	RCCM	—Roan Consolidated Copper Mines, Ltd.
GAO	—General Accounting Office	RCRA	—Resource Conservation and Recovery Act
GATT	—General Agreement on Tariffs and Trade	ROW	—rest-of-world (i.e., non-U. S.)
Gécamines	—La Générale des Carrières et des Mines du Zaïre	RPPI	—relative purchasing power index
GNP	—gross national product	s	—sulfur
GSP	—Generalized System of Preferences	SC/SA	—single contact/single absorption
H <sub>2</sub> SO <sub>4</sub>	—sulfuric acid	Si	—silicon
ICCC	—Inspiration Consolidated Copper Company	<b>SO*</b>	—sulfur dioxide
		SX-EW	—solvent extraction-electrowinning
		tpy	—tonnes per year
		tr oz	—troy ounce
		Us.	—United States

UG	—underground	USGS	—U.S. Geological Survey
$\mu$	—micrometer	UT	—Utah
UNCTAD	—United Nations Conference on Trade and Development	WBMS	—World Bureau of Metal Statistics
UNIDO	—United Nations Industrial Development Organization	ZCCM	—Zambia Consolidated Copper Mines Ltd.

## Appendix B

# Glossary

---

- ADIT:** Underground mine entrance.
- ALLOY:** A material composed of two or more metals (or a metal and nonmetal).
- ALLUVIUM:** Deposits of silt or silty clay laid down during floods in relatively recent times (geologically).
- ANODE COPPER:** The product of fire refining, termed anode because it is the positive terminal in the electrolytic cell for electrorefining.
- AUTOGENOUS:** Occurring or produced without external influence or aid; ore grinding is said to be autogenous when it is done using pieces of ore without the use of steel balls or rods or other grinding media.
- AZURITE:** A deep-blue to violet-blue mineral:  $\text{Cu}_3(\text{CO}_3)_2(\text{OH})_2$ . A common secondary mineral associated with malachite in the upper (oxidized) zones of copper veins.
- BENEFICIATION: Improvement** of the grade of ore by milling, flotation, or other processes.
- BLISTER COPPER:** The product of smelting, called "blister" because the residual sulfur and oxygen form bubbles on the surface as the metal cools.
- BORNITE:** A mineral,  $\text{Cu}_5\text{FeS}_4$ , isometric, reddish-brown, readily tarnishing to iridescent blue or purple "peacock ore".
- BRASS: An alloy of copper and zinc.**
- BRONZE: An** alloy of copper and tin.
- BYPRODUCT: A metal (e.g., molybdenum, gold, silver, cobalt) or other substance (such as sulfuric acid) produced in addition to the principal product, and whose value is substantially less than that of the principal product.**
- CALCINE:** The partially oxidized copper resulting from roasting.
- CARBONATES: Mineral compounds characterized by the fundamental anionic structure of  $\text{CO}_3^{2-}$ .**
- CATHODE: The product of electrorefining, the most common primary copper product.**
- CHALCOCITE: A black or dark lead-gray mineral:  $\text{Cu}_2\text{S}$ .**
- CHALCOPYRITE: A bright brass-yellow tetragonal mineral:  $\text{CuFeS}_2$  (copper pyrite).**
- CHRYSOCOLLA: A mineral,  $(\text{Cu,Al})_2\text{H}_2\text{Si}_2\text{O}_7(\text{OH}) \cdot n\text{H}_2\text{O}$ , that usually occurs as green to blue-green incrustations and thin seams in the oxidized zone of copper sulfide deposits.**
- COMMINATION:** The reduction of ore to a fine powder (pulverization) to prepare it for further processing.
- CONCENTRATE:** The valuable fraction of ore that is left after worthless material is removed in processing. In copper production, concentrates are the result of beneficiation, and are sent to the smelter for further processing.
- CONDUCTIVITY:** The quality or power of conducting or transmitting, usually heat or electricity.
- ELECTRICAL CONDUCTIVITY:** The ratio of the electric current density to the electric field in a material.
- MASS CONDUCTIVITY:** The measurement of electrical conductivity based on the mass of the conducting material.
- VOLUMETRIC CONDUCTIVITY:** The measurement of electrical conductivity based on the volume of the conducting material.
- CONGLOMERATE: A coarse-grained** rock composed of fragments larger than 2 mm in diameter set in a fine-grained matrix of sand or silt; the consolidated equivalent of gravel.
- CONVERTING:** The chemical conversion, using heat, of matte to blister copper, slag, and sulfur dioxide.
- COPPER:** A reddish or salmon-pink isometric mineral, the native metallic element Cu.
- CO-PRODUCT:** A metal (e.g., molybdenum, gold, silver, cobalt) or other substance (such as sulfuric acid) produced in addition to the principal product, and whose value is roughly equal to that of the principal product.
- COUNTRY ROCK:** The rock enclosing or traversed by a mineral deposit or vein, or by an igneous intrusion.
- COVELLITE: An indigo-blue hexagonal mineral:  $\text{CuS}$ . It is a common secondary mineral and an ore of copper.**
- CUPRITE: A red isometric mineral  $\text{Cu}_2\text{O}$ .**
- DENSITY:** The mass or quantity of a substance per unit volume, usually expressed in grams per cubic centimeter.
- DEPOSITION:** The laying down of rock-forming material by any natural agent, such as the settling of sediment from water.
- DRIFT:** A horizontal underground passage driven along a mineral vein.
- DUCTILE:** Said of a rock that is able to sustain 5-10 percent deformation before fracturing or faulting.
- ELECTROMETALLURGY:** The branch of process metallurgy dealing with the use of electricity for smelting or refining of metals. The electrochemical effect of an electric current brings about the reduction of metallic compounds, and thereby the extraction of metals from their ores (electrowinning) or the purification of the metals (electrorefining).
- ELECTROREFINING:** A purification process in which an impure metal anode is dissolved electrochemically in a solution of a salt of the metal being re-

- fined; the pure metal is recovered by electrodeposition at the cathode.
- ELECTROWINNING:** The recovery of a metal from its ore by dissolving a metallic compound in a suitable electrolyte and reducing it electrochemically through passage of a direct electric current.
- EXOTHERMIC:** Pertaining to reactions that generate heat.
- EXPLORATION:** The search for and discovery of new mineral deposits, plus the evaluations necessary to make a decision about the size, initial operating characteristics, and annual output of a potential mine.
- FAULT:** A fracture or fracture zone along which there has been displacement of the sides relative to one another and parallel to the fracture.
- FLOTATION:** The separation of materials by agitation in a chemical solution.
- GANGUE:** The valueless rock or mineral aggregates in an ore; that part of an ore that is not economically desirable but cannot be avoided in mining. It is separated from the ore minerals during concentration.
- GEOBOTANY:** The visual study of plants and their distribution as indicators of soil composition and depth, bedrock lithology, the possibility of ore bodies, and groundwater conditions.
- GEOCHEMISTRY:** The study of the distribution and amounts of the chemical elements in minerals, ores, rocks, soils, water, and the atmosphere.
- GEOLOGIC MAP:** A map on which is recorded the distribution, nature, and age relationships of rock units and the occurrence of structural features.
- GEOLOGIC STRUCTURE:** The attitude and relative positions of the rock masses of an area; the sum total of structural features resulting from such processes as faulting, folding, and igneous intrusion.
- GEOPHYSICS:** Study of the physical properties of the earth (e.g., magnetism) by quantitative physical methods. The geophysical properties and effects of subsurface rocks and minerals that can be measured at a distance with sophisticated electronic equipment include density, electrical conductivity, thermal conductivity, magnetism, radioactivity, elasticity, specific gravity, and seismic velocity.
- GEOSTATISTICS:** The use of statistical methods to describe or analyze geological data.
- GLANCE:** A mineral that has a splendid luster.
- GOSSAN:** An iron-bearing weathered product overlying a sulfide deposit. Gossan is formed by the oxidation of sulfides and the leaching-out of the sulfur and most metals, leaving hydrated iron oxides and, rarely, sulfates.
- GREEN FIELD:** A new project or facility.
- HALO:** A circular or crescent-shaped distribution pattern about the source of a mineral or ore. A halo is encountered principally in magnetic and geochemical surveys.
- HOST ROCK:** Rock that is older than rocks or minerals introduced or formed within it.
- HYDROCYCLONE:** A centrifugal device for separating materials according to weight or size.
- HYDROMETALLURGY:** The extraction and recovery of metals from their ores by processes in which aqueous solutions play a predominant role. Two distinct processes are involved in hydrometallurgy: transferring the metal values from the ore to solution via leaching; and recovering the metal values from solution.
- HYDROTHERMAL ALTERATION:** Alteration of rocks or minerals by the reaction of hot water.
- IGNEOUS:** Describing a rock or mineral that solidified from molten or partly molten material, i.e., from a magma; also, applied to processes relating to the formation of such rocks. Igneous rocks constitute one of the three main classes into which rock is classified, the others being metamorphic and sedimentary.
- INTRUSIVE:** 1) Describing the emplacement of magma in pre-existing rock, or the rock mass so formed; 2) describing an injection of sedimentary material under abnormal pressure, or a rock or structure so formed.
- LEACHATE:** A solution obtained by leaching.
- LEACHING:** 1) The extraction of soluble metals or salts from an ore by means of slowly percolating solutions; e.g., the separation of copper by treatment with sulfuric acid. 2) The dissolving of soluble constituents from a material by the natural action of percolating water; e.g., the leaching of metals from mine wastes.
- LINEAMENT:** A linear topographic feature of regional extent that is believed to reflect the underlying structure of the earth's crust.
- LITHOLOGY:** The description of rocks on the basis of characteristics such as color, mineralogic composition, and grain size; the physical character of a rock.
- MALACHITE:** A bright green mineral,  $\text{Cu}_2\text{CO}_3(\text{OH})_2$ . A common secondary mineral associated with azurite in the oxidized zone of copper sulfide deposits.
- MALLEABLE:** Capable of being extended or shaped (e.g., by pressing with rollers or beating with a hammer).
- MASSIVE SULFIDE DEPOSITS:** Any mass of unusually abundant metallic sulfide minerals.
- MATTE:** The molten product of smelting.
- METALLURGY:** The science and art of separating metals from their ores and preparing them for use, as by smelting and refining.
- METRIC TONNE:** A unit of weight equal to 1000 kilo-

- grams. 1 metric tonne = 1.1 short tons = **2204.6 pounds.**
- MOLYBDENITE:** A lead-gray hexagonal mineral:  $\text{MoS}_2$ . It is the principal ore of molybdenum, Molybdenite generally occurs in foliated masses or scales, and is found disseminated in porphyry.
- MOLYBDENUM:** An element, Mo, often produced as a byproduct of copper mining.
- ORE GUIDES:** **Associations of geologic and other factors such as rock types, geologic structures, or alteration zones that may indicate the presence of an ore body.**
- OUTCROP:** **That part of a geologic formation or structure that appears at the surface of the earth.**
- OXIDATION:** The addition of oxygen to a compound or the removal of an electron from an atom, ion, or element (opposite of reduction).
- OXIDE:** A mineral compound characterized by the linkage of oxygen with one or more metallic elements, such as cuprite ( $\text{Cu}_2\text{O}$ ).
- OXIDIZE:** To add oxygen to a compound, or otherwise cause an atom, ion, or element to lose an electron (opposite of reduce).
- PHENOCRYSTS:** **One of the relatively large and ordinarily conspicuous crystals of the earliest generation in a porphyritic igneous rock.**
- PHOTO GEOLOGY:** The geologic interpretation of aerial photographs.
- PORPHYRY:** An igneous rock of any composition that contains conspicuous phenocrysts in a fine-grained ground mass.
- PORPHYRY COPPER DEPOSIT:** **A large body of rock, typically porphyry, that contains disseminated chalcopyrite and other sulfide minerals.** Such deposits are mined in bulk on a large scale, generally in open pits, for copper and byproduct molybdenum. Supergene enrichment has been very important at most deposits, as without it the grade would be too low to permit mining.
- PREGNANT LEACHATE:** **Leachate laden with mineral values and ready for further processing.**
- PROSPECT:** An occurrence of minerals of potential value before that value has been determined by exploration and development.
- PUDDING-STONE:** **A conglomerate consisting of well-rounded pebbles whose colors are in marked contrast with the surrounding matrix.**
- PYROMETALLURGY:** The extraction of metals from ores and concentrates through processes employing chemical reactions at elevated temperatures.
- REAGENT:** **A substance used because of its chemical or biological activity,** such as the reagents used in froth flotation to make the copper minerals water repellent (hydrophobic) without affecting the other minerals.
- RECONNAISSANCE:** **A general, exploratory examination or survey of the main features of a region.**
- REDUCE:** **To remove oxygen from a compound, or otherwise cause an atom, ion, or element to gain an electron (opposite of oxidize).**
- REDUCTION:** The removal of oxygen from a compound or the addition of an electron to an atom, ion, or element (opposite of oxidation).
- ROASTING:** In pyrometallurgical processes, the treatment of ore or concentrates to dry and/or preheat the material prior to smelting, and/or to partially oxidize the sulfur content to sulfur dioxide for environmental control. In hydrometallurgical processing, roasting converts sulfide minerals to more easily leachable oxides and sulfates, and generates sulfuric acid for leaching. The product of roasting generally is called calcine.
- SEDIMENTARY:** **Pertaining to or containing sediment, or formed by its deposition.**
- SEMI-AUTOGENOUS:** **Occurring or produced with only partial external influence or aid;** ore grinding is said to be semi-autogenous when it is done using pieces of ore mixed with a minimal amount of pebbles, steel balls or rods, or other grinding media.
- SHAFT:** A vertical passage drilled to gain access to a mineral deposit or vein for underground mining.
- SILICATES:** **Compounds whose mineral structure contains  $\text{SiO}_4$  tetrahedral, either isolated or joined through one or more of the oxygen atoms to form groups, chains, sheets, or three-dimensional structures with metallic elements.**
- SMELTER:** **A plant or section of a plant where roasting (optional), smelting, and converting take place.**
- SMELTING:** The chemical conversion, using heat, of copper concentrates or calcines to matte, slag, and sulfur dioxide.
- SOLUTION MINING:** The dissolving of mineral components from an ore (i.e., leaching). In situ solution mining leaching solution trickles downward through the fractured ores or old mine workings to a deeper collection point.
- SOLVENT:** A usually liquid substance capable of dissolving or dispersing one or more other substances.
- SOLVENT EXTRACTION:** The separation of materials of different chemical types and solubilities by selective solvent action (some materials are more soluble in one solvent than in another, hence there is a preferential extractive action).
- STOPE:** **An underground excavation formed by the extraction of ore.**
- STOPING:** Extraction of ore in an underground mine by working laterally in a series of levels in the plane of a vein.
- STRATA-BOUND:** Mineral deposits confined to a single stratigraphic unit. The term can refer to a strati-

form deposit, to variously oriented orebodies contained within the unit, or to a deposit containing veinlets and alteration zones that may or may not be strictly conformable with bedding.

**STRATIFORM:** Having the form of a layer or bed.

**SULFIDES:** Mineral compounds characterized by the linkage of sulfur with one or more metals (e.g., galena—PbS; pyrite—FeS<sub>2</sub>; chalcocite—Cu<sub>2</sub>S).

**SUPERGENE ENRICHMENT:** The near-surface processes of mineral deposition, in which oxidation produces acidic solutions that leach metals, carry them downward, reprecipitate them, thus enriching sulfide minerals already present.

**THERMAL CONDUCTIVITY:** The rate of heat flow by conduction per unit area per unit temperature gradient.

**TROY OUNCE:** A unit of weight. 12 troy ounces = 1 pound.

**WEATHERING:** The physical disintegration and chemical decomposition of rock through exposure to atmospheric agents, producing an in-place mantle of waste and preparing sediments for transportation.

## Appendix C

# Acknowledgments

---

We are grateful to the many individuals who shared their special knowledge, expertise, and information about the copper industry, copper markets, and production technology with the OTA Staff in the course of this study. Others provided critical evaluation and review during the compilation of the report.<sup>1</sup>

Robin Adams  
Resource Strategies Inc.

Jon K. Ahlness  
U.S. Bureau of Mines

T S Ary  
U.S. Bureau of Mines

Kenneth J. Barr  
Cyprus Minerals Inc.

Aldo Barsotti  
U.S. Bureau of Mines

Gary Baughman  
Colorado School of Mines

Julie Beatty  
Resource Strategies Inc.

Harold Bennett  
U.S. Bureau of Mines

John Bennett  
U.S. Bureau of Mines

Sandy Blackstone  
University of Denver

James Boyd  
Newmont Mining Corp.

John Breslin  
U.S. Bureau of Mines

Keith Brewer  
Canadian Department of  
Energy, Mines and Resources

David Brown  
U.S. Bureau of Mines

Charles S. Burns  
Phelps Dodge Corp.

Audrey B. Buyrn  
Office of Technology  
Assessment

Duane Chapman  
Cornell University

David Cole  
Colorado Mining Association

James Cooney  
British Columbia Office of the  
Federal Economic  
Development Coordinator

John Cordes  
Colorado School of Mines

Philip Crowson  
Rio Tinto Zinc Corp.

James W. Curlin  
Office of Technology  
Assessment

Roger Dewey  
Denver, Colorado

Denny Dobbin  
U.S. Public Health Service

Phil Drury  
U.S. Department of Commerce

Daniel Edelstein  
U.S. Bureau of Mines

Roderick Eggert  
Colorado School of Mines

Herman Enzer  
U.S. Bureau of Mines

Brian E. Felske  
Brian E. Felske & Associates  
Ltd.

Frank Fisher  
U.S. Bureau of Mines

Patricia Foley  
CRU Consultants Inc.

Michael Fraser  
Cyprus Minerals Inc.

R.J. Fraser  
AM&S Mining Pty., Ltd.

Robert Friedman  
Office of Technology  
Assessment

Bernard Gelb  
Congressional Research Service

David Glancy  
U.S. Department of Commerce

John Gracey  
JACA Corp.

William Grant  
Utah International Inc.

Sidney Green  
TerraTek

Dorothy Gusler  
AMAX inc.

Graham Haclin  
Brook Hunt and Associates,  
Ltd.

Frank Harris  
Magma Copper Co.

George M. Hartley  
Copper Development  
Association

Thomas Henrie  
Salt Lake City, Utah

Clifford Hicks  
Arizona Department of Mines  
and Mineral Resources

James Hill  
New Mexico Department of  
Energy and Minerals

Dale Huff man  
Cyprus Minerals Corp.

Simon Hunt  
Brook Hunt and Associates,  
Ltd.

Garret R. Hyde  
U.S. Bureau of Mines

Wayne Jackson  
U.S. Bureau of Mines

Kenan Jarboe  
Office of Senator Bingaman

Warren Jenkins  
Copper Range Co.

<sup>1</sup>Affiliated with the OTA staff at the time of consultation with OTA staff



**Jeremy Johnson**  
**Chase Manhattan Bank**

**Janice Jolly**

**U.S. Bureau of Mines**

Dan Kimball  
 National Park Service

Keith Knoblock  
 American Mining Congress

Frank Kottlowski  
 New Mexico Bureau of Mines  
 and Mineral Resources

Judy Kowalski  
 Office of Technology  
 Assessment

Jerry Krim  
 U.S. Bureau of Mines

Philip Lapat  
 Newmont Services Ltd.

Gordon Lister  
 BP Minerals America

David Litvin  
 The Standard Oil Co. (Ohio)

John McIver  
 Magma Copper Co.

Stanley Margolin  
 Network Consulting Inc.

Chuck Marshall  
 JACA Corp.

Dan Maxim  
 Everest Consulting Associates  
 Inc.

Joe Mayer  
 Copper and Brass Fabricators  
 Council

P.K. Rana Medhi  
 Cyprus Johnson Copper Co.

Stanley Miller  
 U.S. Bureau of Mines

Gordon Miner  
 U.S. Bureau of Mines

Paul Musgrove  
 Noranda Inc.

Richard Newcomb  
 University of Arizona

Nyal Niemuth  
 Arizona Department of Mines  
 and Mineral Resources

Anthony Oprychal  
 U.S. Bureau of Mines

**Allan Oshiki**  
**Magma Copper Co.**

**F. Taylor Ostrander**  
**AMAX Inc.**

Krishna Parameswaran  
 Asarco Inc.

David Parker  
 Asarco Inc.

David Parker  
 Government of Western  
 Australia

Jack Parry  
 Magma Copper Co.

Richard Pendleton  
 Phelps Dodge Corp.

Kenneth Porter  
 U.S. Bureau of Mines

Tom Probert  
 BP Minerals America

R.J. Pursley  
 Arizona Mining Association

Paul Queneau  
 Hazen Research Inc.

Martin Robbins  
 Colorado School of Mines  
 Foundation, Inc.

Elizabeth Robinson  
 Morgan Guaranty Trust Co.

Emil Romagnoli  
 Asarco Inc.

Matthew Scanlon  
 Phelps Dodge Corp.

Tom Scartaccini  
 Asarco Inc.

John J. Schanz, Jr.  
 Congressional Research Service

Randall Scott  
 Pincock, Allen & Holt, Inc.

William Shafer  
 House interior Committee

Monte B. Shirts  
 U.S. Bureau of Mines

Pamela Smith  
 U.S. Bureau of Mines

Louis Sousa  
 U.S. Bureau of Mines

Richard Sparks  
 Inspiration Consolidated Copper  
 co.

William Stewart  
 U.S. Bureau of Mines

David Stonfer  
 U.S. Department of Commerce

Simon D. Strauss  
 New Rochelle, New York

George Swisko  
 U.S. Bureau of Mines

Paul Thomas  
 Economics Institute

Gordon Thompson  
 Cominco Ltd.

John E. Tilton  
 Colorado School of Mines

Jake Timmers  
 Inspiration Consolidated Copper  
 co.

Al Tittes  
 Inspiration Consolidated Copper  
 co.

Thomas Terries  
 Terries & Associates

William A. Vogely  
 The Pennsylvania State  
 University

John L. Way  
 EXXON Minerals Corp.

Alfred Weiss  
 Mineral Systems Inc.

Dan Welker  
 Phelps Dodge Corp.

Robert Wilson  
 National Critical Materials  
 Council

J. Burgess Winter  
 BP Minerals America

Harry J. Winters, Jr.  
 Tucson, Arizona

Brian R. Woolfe  
 Magma Copper Co.

Robert Yuhnke  
 Environmental Defense Fund

Klaus Zwilski  
 National Materials Advisory  
 Board

## General Index

- Acid markets, 202-203
- Acid plants, 20, 163-166, 196
- Acquired Immune Deficiency Syndrome (AIDS), 20, 75, 205
- Advertising, 32-33, 249
- Africa, 97, 99, 164
- Air quality
  - Control costs, 20, 31, 168-170
  - Controls, 20, 31, 156-157, 163-168
  - Impacts, 162-163
  - Regulation, 27, 163, 206, 238, 241-242
- Alaska, 49, 98
- Albania, 85
- Alcan, 252
- Alcoa, 252
- Aluminum, 9, 11, 32, 59-60, 79, 91, 250, 252-253
- American Mining Congress, 32
- American Society of Mechanical Engineers, 32
- Amoco, 5, 50, 207, 226, 246-247
- Anaconda Minerals, 5, 48, 49, 50, 52, 113, 163, 226, 242, 246-248
- Angola, 205, 235
- Arco Corporation, 50, 246-247, 252
- Argentina, 92
- Arizona, 12, 29, 40, 47, 48-50, 67, 69, 97, 133, 175, 179, 239, 243
  - Ajo, 49, 113, 166
  - Bisbee, 48, 49, 74, 109, 112, 193
  - Casa Grande, 126
  - Claypool, 50
  - Clifton/Morenci, 49, 112
  - Douglas, 13
  - Globe, 48-49, 113
  - Miami, 113
- Arizona Copper Company, 49
- Asarco, 5, 41, 42, 49, 50, 52, 163, 179, 202, 206, 212, 233, 246-247
- Australia, 19, 39, 67, 70, 74, 92, 97, 197-201, 204, 206-207, 213-214, 215, 218
- Automated controls, 19-20, 41
- Automobile industry, 33, 76, 79, 251
- Belgium, 70, 78, 83, 209, 213-214
- BP Minerals America, 40, 50, 66, 202
- British Metal Corp., 209
- Brass mills, 27, 78
- Brazil, 70, 74, 210
- Broken Hill Proprietary, 207
- Bulgaria, 85
- Byproducts and co-products, 7, 92-94, 99, 202, 210-211
  - Arsenic, 162-163
  - Bismuth, 94
  - Cadmium, 94
  - Cobalt, 94, 210
  - Costs, 187
  - Elemental sulfur, 165
  - Gold, 92-94
  - Gypsum, 163
  - Iron, 94
  - Lead, 94
  - Liquid sulfur dioxide, 165
  - Molybdenum, 92-94
  - Nickel, 94
  - Silver, 92
  - Sulfuric acid, 20, 31, 81, 161-170, 196
  - Zinc, 94
- Calumet & Arizona Mining Company, 49
- Canada, 13, 20, 25, 26, 31, 39, 65, 67, 68, 70, 73-74, 82, 83, 92, 170, 197-201, 203-204, 210, 213-215, 217-218, 233-234
- Capacity, 65-66, 188-189, 210, 216
  - Mine, 5, 39, 47, 53-54, 58, 74
  - Smelter, 20, 69
  - Refinery, 70
- Capacity Utilization, 5, 19, 66
- Centromin Peru S. A., 52, 69
- Cerro, 206
- Chile, 13, 15, 17, 19, 20, 39, 47, 49, 51, 52, 53, 54, 64, 65, 67, 69, 70, 72, 74, 75, 78, 81, 82, 83, 84, 92, 97, 170, 193, 197-201, 204, 210, 213-218, 234
- CIPEC (Intergovernmental Council of Copper Exporting Countries), 19, 31, 39, 235
- Cities Service, 50, 246-247
- Clean Air Act, 81, 82, 163, 170, 238, 241
- Clean Water Act, 172, 238-239
- CODELCO, 17, 51, 52, 67, 199-201
- Coinage, 11, 27, 31, 246
- Colombia, 208
- Cominco, 204
- Committee on Materials, 243
- Commodity Exchange
  - Commodity Exchange of New York (COMEX), 54-56
  - London Metal Exchange (LME), 54-56
  - Pricing, 54-56
- Comparative advantage, 222-223
- Competitiveness, 15-16, 221-253
  - And staying power, 227-228
  - And technology, 16, 19-20, 226-227
  - Effects of environmental regulation, 240-242
  - Industry strategies, 246-253
  - Measures of, 221-228
- Comprehensive Environmental Response, Compensation and Liability Act (Superfund), 172, 239
- Congressional Budget Office, 25, 229-230
- Congressional Copper Caucus, 6
- Construction industry, 10, 58, 76-77
- Consumer goods, 10, 76-77
- Consumption, 13, 16-19, 39-41, 63-65, 76-78
- Converting, 135-137, 167-168
- Copper
  - Anode, 7
  - As a byproduct, 11, 65, 67, 97-98, 99, 201
  - Blister, 7
  - Cathode, 7

- Concentrate, 7
- Fabricated and semi-fabricated products, 78
- Matte, 7
- Properties, 5, 9, 60, 76-77
- Quality, 32, 60
- Refined products, 7
- Scrap, 11, 69, 70, 78
- Uses, 5, 10-11, 13, 76-77
- Copper Development Association, 79
- Copper Ore, 91-100, 186-188
  - Carbonates, 91
  - Cut-off grade, 41-42, 99-100, 153, 186
  - Grade, 6, 9, 15, 40-41, 47, 98-100, 186-187, 216
  - Massive sulfide deposits, 92
  - Oxides, 7, 15, 28, 58, 91
  - Porphyry deposits, 15, 49, 92, 112-113
  - Resources and reserves, 9, 15, 94-98
  - Silicates, 91
  - Strata-bound deposits, 92
  - Sulfides, 7, 15, 91-92
- Copper Producer/Consumer Forum, 31, 234-235
- Copper Range Company, 12-13, 50, 202, 212, 246-248
- Costs, 185-218, 225, 241
  - Capital, 45, 47, 48-49, 108-109, 169-170, 173, 192
  - Concepts and Definitions, 185-186, 197
  - Production, 15-16, 19, 41-42, 72-74, 185-218
- Crushing and grinding (comminution)
  - Costs, 127
  - Energy use, 154-155
  - Technology, 41, 127-129
- Cuba, 85
- Cyprus, 92
- Cyprus Minerals Company, 42, 50, 126, 202, 212-213, 226, 246-247
- Czechoslovakia, 85
- Defense policy, 25, 27, 235-237
- Defense Production Act, 27, 236-237
- Degussa, 209
- Demand growth, 16-19, 20, 23, 39-41, 58-59, 63-65, 76-80
- Detroit Copper Company, 49
- Diversification, 19
- Doe Run Co., 233
- Duval Corporation, 50, 231
- Education and training, 24, 29-31
- Electrical and electronics industry, 10, 58, 76-77, 79
- Electrorefining, 7, 70, 142, 157-158
- Electrowinning, 7, 70, 142-143, 157-158
- ENAMI, 52, 199
- Energy
  - Costs, 19, 67, 192, 204
  - Use, 41, 127, 151-158, 192
- Environmental regulation, 24-25, 31, 41, 47, 161-162, 202, 237-242
- Equipment vendors, 13
- Exchange rates, 19, 23, 31, 60, 64, 210-211
- Exploration
  - costs, 114
  - Technology, 113-115
- EXXON, 50
- Falconbridge, 197, 204
- Financing, 16, 52-54, 56-57, 192
- Finland, 65
- Fire refining, 70, 137
- Flotation (beneficiation)
  - costs, 131-133
  - Energy use, 154-155
  - Technology, 130-133
- Flue gas desulfurization, 166
- France, 78, 83
- Freeport McMoran, 208
- Fugitive emissions, 162, 167-168, 170
- Gecamines, 17, 52, 68
- General Accounting Office, 169
- General Agreement on Tariffs and Trade (GATT), 31, 231
- German D. R., 85
- Germany, F. R., 65, 70, 78, 80-81, 83, 84, 208-209, 213-214
- Gross national product (GNP), 5, 9, 58-59
- Health and safety, 41
- Hecla Mining Company, 126
- Highland Valley, 204
- Highmont Mining Corp., 204
- Hudson Bay Mining and Smelting Company, 50, 234
- Hungary, 85
- Hydrometallurgy, 7
  - Costs, 140, 196
  - Energy use, 157
  - Technology, 140-142
- In-pit crushing and conveying systems, 28-29, 41
- INCO, 197, 204
- India, 210
- Indonesia, 19, 39, 92, 94, 197-201, 207-208, 213-214, 215, 218
- Industrial machinery and equipment industry, 10, 76-77, 226, 249
- Industrial policy, 244-246
- Inflation, 210-211
- Infrastructure, 47, 193
- Inspiration Consolidated Copper Company, 42, 50, 113, 168, 202, 212, 247
- Interest rates, 16, 53, 64, 192
- Intergovernmental Council of Copper Exporting Countries (CIPEC), 19, 31, 39, 235
- International financing institutions, 19, 52-54, 192, 223, 242
  - Inter-American Development Bank, 53
  - International Monetary Fund, 31, 53, 54, 233
  - World Bank, 16, 53, 170, 241-242

- International Trade Commission, 231-233  
 Inventories, 13-15, 16-19, 20, 23, 39-41, 53-54, 57, 63-65  
 Investment risk, 45-47, 53, 186, 191  
 Iran, 92, 210  
 Iron precipitation, 7, 141  
 Israel, 103  
 Italy, 78, 83
- Japan, 20, 65, 70, 72, 78, 80-81, 83, 164, 170, 204, 208-209, 213-214, 234
- Kaiser, 252  
 Kennecott Corporation, 5, 42, 49, 50, 66, 69, 212, 226, 246-247  
 Kidd Creek, 204  
 Korea D. P.R., 85
- Labor  
 Numbers of employees, 12, 40  
 Productivity, 6, 15, 28, 31, 40, 41, 67, 212  
 Strikes, 16, 65, 68, 193, 212  
 Wages and salaries, 6, 19, 41, 64-65, 67, 193, 203, 204, 212
- Leaching (solution mining), 7, 15, 28, 41, 58, 72-74, 99-100, 112, 118-119, 126, 157, 196
- Leadtimes, 45, 191
- Less-developed countries (LDCs), 15-16, 23, 25, 31, 39, 46, 47, 50-52, 52-54, 58, 63, 193, 204, 222-223
- Life span, 191
- Location, 192-193
- Louisiana Land & Exploration, 50, 246-248
- Lornex Mining Corp., 204
- Magma Copper, 42, 50, 69, 202, 226, 246-247
- Marine anti-fouling (bottom paint), 10, 79-80
- Market share, 15, 26, 223-224
- Marketing, 249
- Marmon Group, 52
- Melting and casting, 145-147
- Metallgesellschaft, 209
- Mexico, 17, 20, 49, 51, 52, 67, 74, 75, 92, 97, 170, 197-201, 204, 206, 213-214, 215, 218
- Miami Copper Company, 50
- Michigan, 13, 48, 67, 69, 97, 107
- Minerals policy, 242-243
- Minero Peru, 52, 65, 69
- Mining  
 Costs, 116-118, 185-218  
 Energy use, 152-153  
 Open pit, 7, 118  
 Plans, 41-42, 67, 75, 99  
 solution, 7, 15, 28, 41, 58, 72-74, 99-100, 112, 118-119, 126, 157  
 Technology, 41, 116-126  
 Underground, 7, 118
- Mining and Excavation Research Institute, 32
- Mining and Mineral Policy Act of 1970, 27, 29
- Minnesota, 98
- Mitsubishi Corporation, 81
- Montana, 48, 50, 67, 97, 98, 107, 115
- Montana Resources Inc., 202, 212, 247-248
- Mozambique, 205, 235
- Namibia, 197, 199, 215
- National Bureau of Standards, 243
- National Cooperative Research Act of 1984, 32, 249
- National Defense Stockpile, 13-15, 27, 236-237
- National Environmental Policy Act (NEPA), 172, 237-238
- National Materials and Minerals Policy, Research and Development Act of 1980, 242-243
- National Strategic Materials and Minerals Program Advisory Committee, 243
- Nationalization, 17, 46-47, 52
- Nevada, 49, 50, 113
- Nevada Consolidated Company, 113
- New Mexico, 20, 47, 49, 67, 69, 74, 75, 97, 113
- Newmont Mining Company, 50, 52, 206, 207, 246-247
- Non-Ferrous Metals Producers Committee (NFMPC), 233-234
- Noranda, 50, 68, 126, 202, 234
- Norddeutsche Affinerie, 209
- North America, 39, 92, 97, 99
- Occidental Petroleum, 50
- Office of Technology Assessment, 6
- Oil companies, 50
- Oman, 210
- Ownership  
 Changes in, 48-52, 58, 223-224  
 Government, 50-52, 223-226, 228
- Pakistan, 92
- Papua New Guinea (PNG), 19, 39, 74, 81, 83, 92, 94, 98, 193, 197-201, 207-208, 213-214, 215, 218
- Pennzoil, 50
- People's Republic of China, 85, 92
- Peru, 13, 17, 19, 39, 47, 49, 52, 67, 69, 70, 74, 75, 83, 92, 97, 170, 193, 197-201, 204, 206, 210, 213-218
- Phelps Dodge Corporation, 5, 48-50, 52, 57, 66, 69, 74, 81, 82, 112, 113, 166, 202-203, 206, 212, 226, 233, 246-247, 253
- Philippines, 54, 67, 70, 81, 92, 94, 98, 197-201, 204, 207, 213-214, 215, 218
- Poland, 85
- Portugal, 74
- Price  
 Byproducts, 64, 198, 210-211  
 Copper, 5, 6, 11, 15, 16-20, 23-24, 39-42, 63-65, 185  
 Structure, 54-60
- Production, 16-19, 39-41, 63-65, 224  
 Capacity, 5, 65-66  
 Mine, 5, 11, 20, 66-69  
 Refinery, 11, 70-72  
 Scale, 188-191  
 Smelter, 11, 69-70, 82
- Profitability, 15, 20, 42, 185, 225-226
- Public profile, 193
- Pyrometallurgy, 7, 133-140, 155-157

- Refining, 7  
Costs, 142, 185-218  
Energy use, 157-158  
Technology, 142-143  
Relative purchasing power, 211-216  
Research and development  
Federally-funded, 29, 243-244  
Corporate, 32, 248-252  
Policy, 24, 29-31, 242-244  
Resource Conservation and Recovery Act (RCRA), 172, 173, 239  
Reynolds, 252  
Rio Tinto Zinc, 207  
Roan Consolidated Copper Mines Ltd.  
Roasting, 134, 156  
Romania, 85
- Safe Drinking Water Act, 172, 239  
Shell Oil Company, so  
Smelting  
Costs, 133-134, 185-218  
Energy use, 155-157  
Pollution control, 20, 135, 156-157, 163-168, 238, 241  
Technology, 20, 133-140  
SOHIO, 50  
Solid and liquid wastes (see water quality)  
Solvent extraction-electrowinning (SX-EW), 7, 11, 19, 20, 25, 28, 41, 58, 72-74, 142, 157, 196, 226-227  
South Africa, 70, 75, 92, 197-201, 207, 213-214, 215, 218, 205, 235  
South America, 92, 95-97, 99, 164  
South Korea, 70  
Southern Peru Copper Company (SPCC), 52, 54, 69, 206  
Spain, 65, 83  
Steel industry, 33, 151, 251-252  
Strategic materials, 13, 76-77  
Stripping ratio, 41-42, 153, 187-188  
Subsidization, 25, 26, 27, 47, 52-54, 192-193, 245  
Substitution, 11, 32, 59-60, 64, 76, 79  
Sumitomo Corporation, 57, 81, 208  
Superconducting materials, 58, 80  
Superior Oil, 50  
Superfund (Comprehensive Environmental Response, Compensation and Liability Act), 172, 239
- Tanzania, 205  
Tax  
Policy, 25-27, 229-231  
Rates, 230  
Tax Reform Act of 1986, 229-230  
Technological innovation, 26, 79-80, 115, 119, 128-129, 131-133, 137-139, 142, 143, 151  
Technology transfer, 28-31, 227-228  
Telecommunications, 76, 79
- Tennessee Copper, 50  
Tintaya, 52, 69  
Trade, 80-84  
Anode, 83  
Blister, 83  
Exports, 12  
Imports, 11, 13  
Net import reliance, 11, 15, 82  
Ores and concentrates, 83  
Policy, 25-27, 231-235  
Refined products, 84  
Trade Act of 1974, 25, 231-232  
Transportation  
Costs, 19, 67, 153, 185  
Industry, 10, 58, 76-77
- Union of Soviet Socialist Republics, 85  
United Kingdom, 78, 83  
United Nations Conference on Trade and Development (UNCTAD), 234-235  
U.S.-Canada Free Trade Agreement, 25, 26, 233-234, 242  
U.S. Department of Commerce, 234,  
U.S. Department of Energy, 243  
U.S. Department of the Interior  
Bureau of Mines, 29, 51, 53, 64, 66, 85, 94-95, 118, 126, 188-189, 197-198, 209-218, 243  
Geological Survey, 29, 94-95, 243  
U.S. Environmental Protection Agency, 166, 168-169, 172-174, 177, 237-240, 244  
Utah, 40, 69, 97, 98  
Utah Copper Company, 112, 113  
Utah International Corporation, 74  
Utah Mines, 204
- Valley Copper Mines Ltd., 204
- Water quality, 170-179  
Control costs, 172-173, 179  
Controls, 174-179  
Impacts, 170, 173-174  
Regulation, 171-172  
Weather, 47, 65, 192-193
- Yugoslavia, 19, 39
- Zaire, 13, 17, 19, 20, 39, 47, 52, 54, 65, 67, 68, 70, 75, 78, 83, 92, 94, 97, 98, 170, 193, 197-201, 204-206, 210, 213-215, 217-218, 235  
Zambia, 13, 17, 19, 20, 39, 47, 51, 52, 54, 65, 67, 68-69, 70, 74, 75, 78, 84, 92, 94, 170, 193, 197-201, 204-206, 210, 213-218, 235  
Zambia Consolidated Copper Mines Ltd. (ZCCM), 17, 51, 52, 68

## Copper Properties Index

- Afton, 204  
 Andina Mine, 192, 193, 199, 201  
 Ansil property, 74  
 Atlanta claim, 48, 49  
 Atlas Mines, 207  
  
 Bagdad Mine, 202  
 Bell, 204  
 Biga Mine (Atlas), 207  
 Bingham Canyon Mine, 6, 40, 49, 50, 66, 67, 98, 112, 189, 191, 197, 202, 216  
 Bougainvillea Mine, 92, 207  
 Butte smelter, 163, 242  
  
 Cananea Mine, 49, 51, 52, 74, 206  
 Cananea smelter, 206  
 Carmen Mine (Atlas), 207  
 Casa Grande Mine, 126, 202  
 Cerro de Pasco, 17, 49, 52  
 Cerro Verde, 17, 52  
 Chambishi Mine, 69  
 Chino Mine, 49, 50, 69, 74, 81, 113, 191, 202, 208, 212  
 Chino Smelter, 191  
 Chuquicamata, 49, 74, 189, 195, 199, 201, 216, 222  
 Cliff Mine, 107  
 Continental Mine (East Berkeley Pit), 67, 202, 248  
 Copper Cliff, 204  
 Copper Flat Mine, 47, 192  
 Copper Queen Mine, 49, 112  
 Cuajone Mine, 192, 206  
  
 Dikuluwe/Mashamba Mine, 204  
 Douglas smelter, 13, 48-49, 50, 69, 112, 241  
  
 Eisenhower Mine, 202  
 El Paso smelter, 163, 202, 212  
 El Salvador, 195, 199  
 El Teniente, 49, 189, 195, 199  
 Ertsberg Mine, 94, 208  
 Esperanza Mine, 202  
  
 Flin Flon smelter, 234  
  
 Garfield smelter, 69  
 Gaspé Mine, 234  
  
 Hayden smelter, 202  
 Hidalgo smelter, 202  
 Highland Valley, 204  
 Highmont, 68  
 Home smelter, 68, 204  
  
 Inspiration Mine, 191, 202  
 Inspiration smelter, 202, 242  
  
 Irish Mag Mine, 49  
 Island Copper, 204  
  
 Kamoto Mine, 204  
 Kansanshi Mine, 69  
 King Solomon's Mines, 103  
 Konkola Mine, 69  
 Kov Mine, 204  
  
 La Caridad Mine, 17, 49, 51, 52, 192, 206  
 La Escondida, 52, 74, 208, 216  
 La Oroya smelter/refinery, 52  
 Lakeshore Mine, 126, 202  
 Lornex, 68, 192, 204  
 Lutopan Mine (Atlas), 207  
  
 Maria Mine, 74  
 McGill smelter, 241  
 Miami Mine, 48, 202  
 Mina Sur, 201  
 Mission Mine, 41, 202  
 Morenci Mine, 57, 74, 81, 189, 202, 208, 212, 246  
 Morenci smelter, 81  
 Mount Isa Mine, 207  
 Mufilira Mine, 205  
  
 Nacozari smelter, 206  
 Neves Corvo Mine, 74, 216  
 New Cornelia Mine, 49, 212  
 Nchanga Division Mines, 189, 205  
 Nkana Division Mines, 205  
  
 Ok Tedi Mine, 74, 94, 207, 216  
 Old Dominion Mine, 48-49, 113  
 Olympic Dam (Roxby Downs), 74, 216  
 Ox Hide Mine, 202  
  
 Palabora Mine, 207  
 Pima Mine, 202  
 Pinto Valley Mine, 50, 202  
 Prieska Mine, 75  
  
 Ray Mine, 49, 50, 113, 191, 202  
 Rio Tinto, 103  
 Rouyn smelter, 234  
 Roxby Downs (Olympic), 216  
 Ruttan Mine, 68, 204  
  
 Salobo Mine, 74, 216  
 San Manuel Mine, 133, 189, 202  
 San Manuel smelter, 69, 202  
 San Xavier Mine, 202  
 Sar Cheshmeh, 192  
 Sierrita Mine, 202, 212, 237  
 Silver Bell Mine, 47, 192, 202  
 Sipalay Mine, 207  
 Sudbury (Falconbridge), 204

Tacoma smelter, 163, 241

Timmins, 204

Tintaya, 192

Toquepala Mine, 192, 206

Troy Mine, 202

Tyrone Mine, 20, 49, 50, 74, 75, 113, 192, 202, 212

United Verde Mine, 48

Valley Copper Mine, 68

White Pine Mine, 13, 50, 202, 248

White Pine smelter, 69, 166, 202