

*Disposal of Chemical Weapons: Alternative
Technologies*

June 1992

OTA-BP-O-95

NTIS order #PB92-202180



B A C K G R O U N D P A P E R

Disposal of Chemical Weapons

ALTERNATIVE
TECHNOLOGIES



CONGRESS OF THE UNITED STATES
OFFICE OF TECHNOLOGY ASSESSMENT

Recommended Citation:

U.S. Congress, Office of Technology Assessment, *Disposal of Chemical Weapons: Alternative Technologies-Background Paper, OTA-BP-O-95* (Washington, DC: U.S. Government Printing Office, June 1992).

For sale by the U.S. Government Printing Office
Superintendent of Documents, Mail Stop: SSOP, Washington, DC 20402-9328

ISBN 0-16 -037951-2

Foreword

The United States has pledged to destroy its entire stockpile of chemical weapons by the end of this decade. The U.S. Army has begun this process by building and testing a demonstration facility to disassemble and incinerate these weapons on Johnston Island, a small island in the mid-Pacific Ocean. After tests prove the concept, the Army plans to build similar facilities for the other chemical weapons now stored at each of eight sites in the continental United States.

Local community groups are opposed to the Army's current program at a number of these sites. The incineration of hazardous materials of all kinds has engendered concerns about public health impacts. Several organizations have suggested that technologies other than incineration may be safer and more appropriate for this program. Because of these factors, Senator Wendell H. Ford asked the Office of Technology Assessment to evaluate the status and availability of alternative technologies for destruction of chemical weapons in the U.S. stockpile as an adjunct to OTA's larger assessment of weapons dismantlement.

This background paper briefly describes the Army's chemical weapons destruction program, discusses the factors that could affect a decision to develop alternatives, discusses the alternatives, and illustrates the difficulty of gaining public acceptance of complex technical systems.

OTA appreciates the assistance and support this effort received from workshop participants, reviewers, and other participants. They provided valuable information that was critical to the completion of this study, and enabled OTA to develop a much more complete and accurate analysis. OTA, however, remains solely responsible for the contents of this report.

JOHN H. GIBBONS
Director

Disposal of Chemical Weapons: Alternative Technologies

Workshop Participants and Reviewers

Workshop Participants

Edgar Berkey
National Environmental Technology
Applications Corp.

Gene Dyer
Bechtel Corp. (Retired) and
Member of the National Research
Council Committee on Review
and Evaluation of the
Army chemical Stockpile
Disposal Program

Larry Eitel
Consultant Chemical Engineer

Richard Eriksson
California Department of Toxic
Substances Control, Alternative
Technologies Division

Walter Kovalick
U.S. Environmental Protection Agency
Technology Assessment

Jack Swearingen
Sandia National Laboratories

Robert Whelen
U.S. Army Chemical
Demilitarization Program

Reviewers

Col. Eric Azuma
Office of the Assistant
Secretary of the Army

Charles Baronian
U.S. Army Chemical
Demilitarization Program

James Bartel
Sandia National Laboratories

Hayden Burgess
Citizen of Waianae, HI

Ned Coale
U.S. Army Chemical
Demilitarization Program

Jeanette Crow
Alabama Conservancy

William Davison
Director
General Atomics

Angela Dooley
Citizen of Pine Bluff, AR

Kevin J. Flamm
U.S. Army Chemical
Demilitarization Program

Bracelen Flood
Concerned Citizens of
Madison County, Kentucky

Terry Galloway
Synthetic Technologies Inc.

Sebia Hawkins
Greenpeace Pacific Campaign

Thomas Hess
Office of the Assistant
Secretary of the Army

Peter Hille
Common Ground

Cathy Hinds
National Toxics Campaign Fund

Valerie Hudson
Kentucky Department for
Environmental Protection

Col. William R. Humbaugh
Ordinance Corps
Lexington-Bluegrass Army Depot

Mark Kagan
The Committee for National
security

Cindy King
Utah Chapter, Sierra Club

Jim Knipp
Citizen of Milan, TN

Linda Koplovitz
Concerned Citizens for
Maryland's Environment

Toni Lampkin
Citizens for Environmental Quality

John Longwell
Massachusetts Institute of
Technology

William McKenna
Department of Army Headquarter
US. Army Armament, Munitions
and Chemical Command

Michael Modell
Modell Development Corp.

Carl Peterson
Massachusetts Institute of
Technology

Al Picardi
Consultant

Robert Sabia
Burns and Roe Industrial
Services Co.

Donald L. Siebenaler
National Academy of Sciences
Board on Army Science and
Technology

Lenny Siegel
Pacific Studies Center
National Toxics Campaign Fund

Jeremy Sprung
Sandia National Laboratories

Ross Vincent
Sierra Club

Thomas J. Wilbanks
Oak Ridge National Laboratories

Craig Williams
Kentucky Environmental Foundation

David Wood
National Toxics Campaign

Rainer Zangerl
Citizen of Rockville, IN

NOTE: OTA appreciates and is grateful for the valuable assistance and thoughtful critiques provided by the workshop participants and reviewers. The workshop participants and reviewers do not, however, necessarily approve, disapprove, or endorse this background paper. OTA assumes full responsibility for the background paper and the accuracy of its contents.

OTA Project Staff—Disposal of Chemical Weapons: Alternative Technologies

John Andelin, *Assistant Director, OTA
Science, Information, and Natural Resources Division*

Robert Niblock, *Oceans and Environment Program Manager*

Peter Johnson, *Project Director*

Mark Brown, *Senior Analyst*

Jan Linsenmeyer, *Research Assistant*

Administrative Staff

Kathleen Beil, *Office Administrator*

Sally Van Aller, *Administrative Secretary*

Contractor

Florence Poillon, *Editor*

Contents

	<i>Page</i>
Chapter 1. Alternative Destruction Technologies-History and Summary	1
INTRODUCTION	1
SUMMARY AND FINDINGS	3
Opposition to the Army's Program	3
Approaches to Developing Technologies	4
Timing Questions	5
Risks of Developing Alternatives	6
Alternative Technologies	6
International Implications	10
CHAPTER 1 REFERENCES	11
Chapter 2. The Army's Chemical Weapons Disposal Program	13
THE U.S. ARMY'S CHEMICAL WEAPONS STOCKPILE	13
Geography and Distribution	13
History of Chemical Weapons Disposal	16
On-Site Destruction vs. Relocation of the CW Stockpile for Off-Site Destruction	17
Condition of the CW Stockpile-Potential of Increased Risk From CW Deterioration	17
DISPOSAL OF THE ARMY'S CW STOCKPILE	18
The Army's Demonstration Projects	18
DIFFICULTIES ENCOUNTERED BY THE CURRENT CW DISPOSAL PROGRAM	18
Local and National Opposition	18
Projected Program Schedule—Revised Deadlines	20
Cost Estimates—Cost Overruns	20
INTERNATIONAL IMPLICATIONS OF A SUCCESSFUL PROGRAM	20
ALTERNATIVE SCENARIOS FOR THE ARMY'S BASELINE PROJECT	22
CHAPTER REFERENCES	23
Chapter 3. Current Technology and Alternatives	25
CURRENT TECHNOLOGY	25
The Army's CW Disassembly and Incineration Technology	25
EXAMPLES OF ALTERNATIVE TECHNIQUES	25
Chemical Neutralization	26
Supercritical Water Oxidation	27
Steam Gasification	27
Plasma Arc Pyrolysis	27
Improved Interim Continued Storage-The CW Demilitarization Alternative	28
Alternatives Involving Transportation and Relocation of the CW Stockpile	28
CHAPTER REFERENCES	29
Appendix A. Selected Chemical Weapon Destruction Techniques	31
Appendix B. U.S. Army Risk Assessment for Off-Site Transportation of Chemical Weapons	36
Appendix C. Summary of the Chemical Weapons Workshop	39

Boxes

<i>Box</i>	<i>Page</i>
I-A. Federal Laws Addressing Chemical Weapons Disposal	2
I-B. State Authority Over the Siting, Construction, and Operation of Incinerators for Chemical Weapons Destruction	4

1-C. Condition of the M55 Rockets	7
1-D. Programs for the Promotion of Alternative Technologies for Hazardous Waste Destruction	9
2-A. Properties of chemical Weapons Agents	14
2-B. Some Regulatory Hurdles for CW Destruction	19

Figures

<i>Figure</i>	<i>Page</i>
1-1. M55 Rocket, Filled With Agent GB or VX	7
2-1. U.S. Chemical Weapons Stockpile Distribution	13
2-2. Structures of Chemical Weapons Nerve (Organophosphorus) and Blister (Mustard) Agents	15

Tables

<i>Table</i>	<i>Page</i>
1-1. Revised Programmatic Chemical Disposal Schedule	3
2-1. Characteristics of Chemical Agents	14
2-2. Physical Characteristics of Chemical Munitions	16
2-3. U.S. Chemical Weapons Disposal Program Implementation Schedule	21

Alternative Destruction Technologies—History and Summary

INTRODUCTION

The U.S. Army currently has custody of chemical weapons (CW) containing nerve and blister (vesicant) agents¹ located at eight sites in the continental United States and at Johnston Island, a small island in the Pacific Ocean. The Army's current disposal program calls for munition disassembly followed by incineration, on-site, at all of the present locations of the CW stockpiles. This approach has met with opposition by some communities and States that have CW stockpiles and by several national and international environmental groups. At the State level, this opposition may succeed in preventing or seriously delaying construction of the Army's planned CW disposal facilities at certain locations. The Army itself has expressed concern about potential regulatory obstacles to completing its CW disposal program. Additional program delays have also been experienced because the Army's Johnston Island demonstration program, required by Congress prior to construction of CW disposal facilities in the continental United States, has not yet been successfully completed.

Because of the legal, social, and technical obstacles faced by the Army, the Office of Technology Assessment (OTA) was asked to examine alternatives to on-site incineration for the destruction of these weapons. This report does not attempt to assess in any detail the technical aspects of the Army's current CW destruction program.² It reviews the status and availability of alternative technologies and discusses the factors that could lead to the consideration of such alternatives.

The need for an effective U.S. CW stockpile destruction program has been driven by several factors. The Army has had its own requirements for a disposal method for surplus and obsolete chemical weapons for as long as these materials have been part of its arsenal. In 1982, Under Secretary of the Army J.R. Ambrose stated in a letter to the chairman of the

National Research Council (NRC) Board on Army Science and Technology that:

[T]he United States faces a formidable problem in disposing of its current obsolete chemical munitions and agent stockpile. About 90 percent of the inventory of chemical agent and nearly as much of the munitions inventory has little or no military value and will require disposal regardless of future decisions regarding the binary weapons program (l).

A related and ongoing concern expressed both by the Army and the NRC is the potentially increasing risk from the existing U.S. CW stockpile as it deteriorates with age.

Congress has directed the Army to develop and implement a CW destruction program (see box 1-A). The Department of Defense Appropriation Act of 1986 (Public Law 99-145) directed the Secretary of Defense to destroy the current U.S. CW stockpile in a safe and effective manner. This directive was originally tied to the Army's acquisition of newer binary chemical weapons, although the development of such weapons is no longer planned and few were actually ever built (2, 3). A plan provided by the Secretary of the Army to Congress in 1986 became the basis of a Programmatic Environmental Impact Statement (PEIS). As the Army's program development encountered unanticipated technical and political hurdles, Congress flexibly responded by amending completion timetables. Initially, the Army was required to destroy its CW stockpile by 1994. In 1988, Congress extended the completion date to 1997. Also in 1988 the Army compared alternatives of relocation of weapons to one or more central disposal sites to that of on-site disposal at each of the eight locations. The Army chose on-site disposal because it believed that any accident on an existing Army base would be easier to mitigate than an accident at some unknown point along a transportation route. Recently, the Army has submitted a revised completion date of 2000 to Congress that maintains the plan to build on-site disposal systems at each of eight sites (see table 1-1) (4, 5, 6).

¹ See box 2-A for a more complete description of chemical weapons agents and their effects.

² It also does not discuss cryofracture, an experimental munitions disassembly technique that freezes and crushes CWS. Cryofracture is part of the current development program and is considered by the Army to be only a "front end" process that must be coupled to incineration, and does not therefore constitute an incineration alternative.

Box I-A—Federal Laws Addressing Chemical Weapons Disposal

A number of laws have been passed over the years that specifically address chemical weapons disposal.

The Department of Defense Authorization Act of 1986 (Public Law 99-145) mandated the destruction of the U.S. stockpile of lethal chemical agents and munitions. It directed the Department of Defense (DOD) to develop a comprehensive plan for destruction of the stockpile, which would be carried out by an Army management organization. The law established a destruction deadline of September 30, 1994, and provided a separate DOD account to fund all activities. The law further required that the Army plan should provide for maximum protection for the environment and human health and that the facilities constructed would only be used for destruction of chemical weapons and munitions. Public Law 99-145 clearly stated that once the stockpile elimination was complete, all facilities would be dismantled and removed.

Amendments and revisions have since been made to the law governing the stockpile destruction requirements and the Chemical Weapons Demilitarization Program. In the *National Defense Authorization Act for Fiscal Year 1988 and 1989* (Public Law 100-180), Congress directed the Secretary of Defense to issue the final Programmatic Environmental Impact Statement on the chemical stockpile destruction program by January 1, 1988. The law further required that funds designated for the program could not be obligated until the Secretary of Defense provides Congress, in writing, proof that the overall concept plan for the Chemical Demilitarization Program includes:

1. An evaluation of alternate technologies for disposal of the existing stockpile, and
2. Full-scale operational verification tests of the selected chemical weapons disposal technology or technologies.

In addition, Public Law 100-180 required the Secretary of Defense to submit an alternative concept plan for the chemical stockpile demilitarization program to both Committees on Armed Services of the Congress. This alternative concept plan was to be completed by March 15, 1988. The law also required the Secretary of Defense to establish an ongoing program for surveillance and maintenance of the stockpile and assess its overall condition.

The National Defense Authorization Act for Fiscal Year 1988 and 1989, (Public Law 100-456) made additional changes that affected the Army's program to destroy the chemical weapons stockpile. This law extended the stockpile elimination deadline to April 30, 1997. It also required the Army to complete Operational Verification Testing (OVT) of its demonstration facility at Johnston Atoll Chemical Agent Disposal System (JACADS) before proceeding with construction of similar full-scale facilities for the destruction of the chemical weapons stockpile located in the continental United States. However, this provision did not prohibit construction activities at the Chemical Agent Munition Disposal System in Tooele, Utah.

The National Defense Authorization Act for Fiscal Year 1991 (Public Law 101-510) also addressed the Chemical Weapons Demilitarization Program. This law pays particular attention to issues involving the safety status and the integrity of the stockpile. In the law, Congress requires the Secretary of Defense to develop a Chemical Weapons Stockpile Safety Contingency Plan. This plan would detail the steps that DOD would follow if the chemical weapons stockpile began an accelerated rate of deterioration or any other question of its integrity arose before full-scale disposal capability was developed. This plan, which is to set forth a planning schedule, funding requirements, equipment needs, and time frame for emergency plan implementation, was to be submitted to Congress 180 days after the law was passed.

Currently, legislation involving the **Chemical Weapons Demilitarization Program addresses the delays in the program** and proposed deadlines. Both the House and Senate bills for *National Defense Authorization for Fiscal Year 1992 and 1993* (S. 1507 and H.R. 2100) propose extending the stockpile elimination deadline to July 1999.

Other laws that helped shape the Chemical Weapons Demilitarization Program include Public Laws 91-672 and 92-532.

The Foreign Military Sales Act Amendment (Public Law 91-672), passed in 1971, prohibited the transportation of chemical weapons from the Island of Okinawa to the United States. It further directed the U.S. Department of Defense to destroy these chemical weapons outside the United States. (In 1971, the U.S. Army moved chemical weapons from Okinawa to storage facilities at Johnston Island.)

The Marine Protection, Research, and Sanctuaries Act of 1972 (Public Law 92-532) prohibited ocean dumping of chemical weapons.

Table I-I—Revised Programmatic Chemical Disposal Schedule

Location	Start facility construction	Start prove-out	Start operations	End operations
Johnston Island.....	November 1985	August 1988	July 1990	October 1995
Training Facility.....	June 1989	N/A	October 1991	December 1999
Tooele Army Depot.....	September 1989	August 1993	February 1995	April 2000
Anniston Depot.....	June 1993	April 1996	October 1997	November 2000
Umatilla Depot.....	January 1994	November 1996	May 1998	December 2000
Pine Bluff Arsenal.....	January 1994	September 1996	March 1998	November 2000
Lexington-Blue Grass.....	May 1994	March 1997	September 1998	February 2000
Pueblo Depot.....	May 1994	March 1997	September 1998	May 2000
Newport Ammo Plant.....	January 1995	June 1997	June 1998	April 1999
Aberdeen Proving Ground. . .	January 1995	June 1997	June 1998	June 1999

NOTE: This schedule does not take into account delays from major system failures or litigation and is dependent on funding support.

SOURCE: S. Livingstone, Assistant Secretary of the Army (Installations, Logistics and Environment), testimony before the House Committee on Appropriations, Subcommittee on Defense, Apr. 1, 1992, Second Session, 102d Congress.

Bilateral treaties that were negotiated with the former Soviet Union (now the Commonwealth of Independent States, C. I. S.) contained deadlines for CW destruction by each signatory. One of these agreements that had been under final negotiation between the United States and the Soviet Union mandated staged destruction over time of the CW stockpile of both countries to 5,000 metric tons of agent by 2002. Even though this agreement has not been put into force, many believe it is in the best interest of the United States to honor its intent if not its timetables. However, both the United States and the C.I.S. are having difficulties in achieving these timetables for several reasons. The C.I.S. currently has no active CW disposal program, and past efforts to develop a disposal facility in the Soviet Union were derailed by local citizen opposition (7). At present, Russia has no project ready for the destruction of an estimated 40,000 tons of chemical weapons agents stored there (8). The agreements that have been negotiated appear to allow flexibility in accommodating technical and other problems that affect CW destruction program timetables. It is becoming clear that the flexibility is needed even given the significant pressures to move ahead expeditiously.

SUMMARY AND FINDINGS

Although the Army has done a credible job developing the technical aspects of its current program, major political and social obstacles re-

main. Analyses other than OTA's of the Army's current program indicate that there are also some remaining technical and cost obstacles (9, 10, 11, 12, 13, 14). At present, the Army has no backup plan should its current program be unsuccessful.

Opposition to the Army's Program

Local and national opposition may be able to prevent or seriously delay construction of the Army's planned CW disposal facilities. For example, the State of Kentucky has passed legislation establishing more stringent measures for the Army to obtain the permits required under the Resource Conservation and Recovery Act (RCRA) (see box I-B). Other States could follow this lead. Also, the Army has not completed a congressionally mandated demonstration of its technology at Johnston Island. It is not clear that this demonstration as presently planned will adequately address concerns raised by groups who oppose the Army's CW program.

The Army itself has been concerned about the difficulties affecting the completion of its current CW disposal program (4). In 1984, after reviewing the Army's experience with CW neutralization and incineration, the National Research Council (NRC) endorsed the Army's decision to use incineration (1).

However, possibly in reaction to political opposition to its program, the Army recently requested the

Box 1-B—State Authority Over the Siting, Construction, and Operation of Incinerators for Chemical Weapons Destruction

The Commonwealth of Kentucky has been delegated authority under the Resource Conservation and Recovery Act (RCRA) and the Clean Air Act to issue within the state construction and operation permits for hazardous waste management facilities such as a CW incinerator. State authority affects all phases of the construction and operation of an incineration facility. Statutes passed under this authority by the Kentucky State legislature have placed additional specific requirements for hazardous waste incinerators intended for use with chemical weapons (the Kentucky Revised Statutes Chapter 224, 224.865) (1). These revisions have not only included CW agents as chemicals to be regulated, but also required that an equivalent treatment/destruction technology be fully demonstrated prior to permitting the proposed CW incinerators.

These revised statutes require submission of:

monitoring data from a comparable facility [that] reflects the absence of emissions from stack or fugitive sources including but not limited to the products of combustion and incomplete combustion which alone or in combination present any risk of acute or chronic human health effect or adverse environmental effect [Kentucky Revised Statute 224.865].

One interpretation of this requirement according to Kentucky State officials as suggested by the Center for Disease Control (CDC) is that it would require a 30-year epidemiological study on a similar site, along with complete monitoring data (1). In addition to State control over new incinerators, local county courts in Kentucky may also have authority to veto the siting of a CW destruction facility.

During the 1992 Session of the Kentucky General Assembly, House Bill 465 was passed and signed by the Governor on April 1, 1992. This legislation, effective July 15, 1992, specifically requires that before a permit can be issued to construct a CW destruction facility information must be provided showing that:

no alternative method of treatment or disposal, including, but not limited to, neutralization and transportation to a less populated disposal site, exists . . . or is likely to exist or could be developed. . . that creates less risk of release or harm to the public or the environment. . .

The legislation also sites State authority under Section 6929 of Title 42 of U.S. Code to:

impose reasonable restrictions directly relating to public health and safety with respect to the management of hazardous wastes beyond the minimum standards established under federal law. [Moreover] [T]here exist

NRC Committee on Review and Evaluation of the Army Chemical Stockpile Disposal Program to reevaluate the status of incineration. An additional NRC committee has also been formed, the Committee on Alternative Chemical Demilitarization Technologies (Alternatives Committee), to examine alternatives for CW disposal. The first meeting of the Alternatives Committee was held in March 1992. Many believe that this new NRC committee effort is important not only because of technical benefits but because it could reflect the Army's willingness to integrate community and environmental concerns in its decisions.

Approaches to Developing Technologies

The nature of the political problems faced by the Army's CW destruction program suggests that completing its present program or developing a successful alternative one involves more than technology development. Any successful program will

need to address the relevant social and political issues involved as well. This is likely to require the active participation of all interested parties, including the Army, regulators, contractors, community organizations, and environmental groups.

Such a collaborative effort could begin by developing criteria for an acceptable program that address the key technical and social obstacles. Features that are important to some groups include:

- Use of a destruction technology that does not have smokestacks, which are associated with uncontrolled environmental emissions;
- Selection of a technology with features specifically appropriate for the CW stockpile and that could not become the basis of continued operation for hazardous waste disposal at the facilities sites;
- Development of portable CW destruction systems that could be used directly in a munition

substantial gaps in information concerning the acute and chronic health effects and environmental consequences of exposure to [chemical weapons agents] and [their] degradation products.. [which] justify the imposition of standards correlative to the uncertainties and severity of risks potentially posed by the treatment or disposal of the compounds.

The legislation specifies **that** before anyone may construct or operate a facility for treatment, storage, or disposal of CW agents, he or she must demonstrate that:

The proposed treatment or destruction technology has been fully proven in an operational facility of scale, configuration and throughput comparable to the proposed facility [to ensure] destruction [efficiency] of 99.9999 percent. . .as achievable during the design life of the facility under all operating conditions including during the occurrence of malfunctions, upsets, or unplanned shutdowns.

The legislation also requires monitoring data from an operation facility showing the “absence of emissions” that “present any **risk of acute or chronic human health effects...**.” Plans are also required for a State and local emergency response.

Representatives from other States legislatures that have CW depots within their States have made inquiries of the Kentucky state authorities about the nature of this strategy. According to a General Accounting Office (GAO) study, other States where the Army **has** proposed constructing CW destruction facilities, such as Indiana have shown an interest in how the Kentucky State legislature has dealt with the Army’s program (2). The State of Utah has enacted legislation affecting the permitting of CW destruction facilities (2). Utah has required that the disposal facility built at Tooele, Utah will operate at 50 percent capacity for 6 months for each and every individual chemical agent to be destroyed (2). State environmental officials will then evaluate test data for the individual agents (2). According to the GAO report, in 1988, the Army’s estimates for construction State dates assumed that State-issued environmental permits for each of the proposed sites could be obtained in 15 months. On the basis of its experience with Utah, the Army now anticipates that it will take 24 months, and it is not clear how realistic even this revised estimate will be (2).

References

1. Hudson, V., Deputy Commissioner for Special Projects, Kentucky Department for Environmental Protection, Frankfort Office Park Frankfort, KY. Telephone Conversation December 12, 1991.
2. U.S. Congress, General Accounting Office, *Stockpile Destruction Cost Growth and Schedule Slippages are Likely to Continue*, GAO/NSIAD-92-18 (Washington, DC: November 1991).

storage facility to avoid risks associated with transporting and handling CWs away from their present storage locations;

- . Development of individual programs with features specific to individual sites; and
- . Development of safe and effective community emergency response programs.

Timing Questions

It is difficult to predict the time that may be required to develop an alternative program given the available information about alternative technologies. It is clear that the alternatives identified by OTA are all in early stages of development—perhaps several years behind the Army program’s current development stage. It is also evident, however, that political or legal delays could prevent implementation of current technology at some or several of the weapons storage sites for a number of years.

While there are pressures to destroy the CW stockpile quickly, there is no technical basis to set absolute deadlines for completion of the CW destruction program. The condition of the existing CW stockpile is probably the most serious consideration but few data and no rigorous, comprehensive analysis of the risks posed by deterioration of the weapons exist. The Army’s monitoring program has yet to identify trends of increasing deterioration. There are also domestic and international political pressures to expedite the weapons destruction program. However, many believe that congressional mandates and the status of bilateral treaties and agreements are sufficiently flexible to consider the development of alternative programs.

As stated above, the least flexible deadline maybe the increasing risk associated with deterioration of the CW stockpile. With the exception of the M55 rockets located at five of the eight continental U.S. sites, the best available information about the

condition of the CW stockpile, including that from ongoing surveys, suggests there are few problems with agent leakage from bombs, artillery projectiles, mines, or bulk storage tanks (1, 15, 16). In 1984 the NRC indicated that although there were insufficient data to project the near-or long-term storage life of CW agent containers, available information suggested that the overall leak frequency had not substantially increased during the lifetime of the CW stockpile (I). However, the report also concluded that the M55 rocket is the primary basis for a maximum credible accident at each of the depots due to the possible harm that could be inflicted on both workers and civilian populations. In a 1985 study by the Army on the condition of the M55 rockets, the occurrence of a catastrophic event from a deteriorating stockpile in the near future was considered highly unlikely (17). Nevertheless, the continued storage of M55 rockets and other types of munitions at Army depots represents a continued, finite risk to communities located near these depots. To better quantify this risk, existing monitoring programs on the status of the U.S. CW stockpile could be expanded to provide additional information about the rate of deterioration of the M55's. In addition, further analyses of the risks from continued storage as well as possible risk reduction measures could be very useful in decisions about time available to pursue alternative programs (see box I-C).

The timing issue is critical in alternative technology development planning. One approach to an alternative program could be to try and find mid-term corrections for the Army's current system, e.g., replacing one or more of the incinerators themselves with some other method of destruction but keeping the rest of the system. Another would be to start over with an entirely new system. The impact on the Army's current program clearly will be quite different with these two approaches. A sense of time constraints will also dictate where a new program can begin. For examples, if lots of time is available, then a new program could afford to begin in the laboratory; if less time is available, then a new program would probably be forced to consider only existing bench-scale technologies or technologies already tested in related areas.

How much time may be available to develop alternatives is not known nor is there an accurate estimate of time required for various approaches. Technical and regulatory hurdles faced by the current program may delay it well beyond its

planned completion date. In any case, a clear analysis of time constraints is critical and it should include costs of delay, the risks of delaying, the degree of uncertainty and other factors.

Risks of Developing Alternatives

Even though it may be desirable to sponsor an alternative technology development program, it is important to understand the risks of such an effort. The prospects for success of an alternative program are not assured. There could always be a number of technical or political problems and delays associated with any development program. Failure of a technology or approach in a full-scale test is always possible. After even the best efforts to develop new technologies, it is possible that the results could be no better or even worse than those from the current system.

Therefore, if an alternative development program was supported it would not necessarily follow that the current program should be stopped. It may be possible to combine the best features of both programs in the future, or it may be that current technologies will be superior to any alternatives in the end.

Alternative Technologies

To be applicable to the current CW stockpile, a technology must be able to effectively destroy or decontaminate the chemical agents, the drained and empty munitions and containers, the associated explosives and propellants, and the munition packaging material (dunnage). The Army's current system incorporates all of these waste streams. Some alternatives that have been proposed, however, may be expected to be useful in destroying only the chemical agent itself. Others could possibly be applicable to other waste streams (e.g., explosives and propellants). In any case, any complete system would need to integrate the capability to handle all waste streams as well as to handle, disassemble, and drain the various types of containers or weapons involved.

OTA reviewed available data on alternative technologies. Of those that have been proposed by others for CW destruction, OTA selected four that are briefly discussed in this report (chemical neutralization, super critical water oxidation, steam gasification, and plasma arc pyrolysis). These four were selected only for the purpose of illustrating the

Box 1-Condition of the M55 Rockets

The M55 rockets (see figure 1-1) are considered the most dangerous items in the current stockpile for a variety of reasons (1, 2). Since the M55 rocket is a fully assembled munition containing either agent VX or GB, along with fuses, burster charges, and propellants-in a configuration that cannot be separated easily-it is the most potentially hazardous item in the CW stockpile (3, 4). The M55 rockets are also the source of the greatest number of leaking munitions. Not surprisingly, M55s are the primary basis for a maximum credible accident at each of the depots where they are located due to the possible harm that could be inflicted on workers and civilian populations (1). Approximately 478,000 M55 rockets are located at five of the eight continental U.S. sites and at Johnston Atoll (3, 4). In part because of these problems, the 1984 National Research Council report recommended that disposal of the M55 rockets be expedited.

Historical records of the M55 rockets are largely lost, destroyed, misfiled, or nonexistent (3, 4). The rockets were developed in the 1950s. The GB-filled rockets were manufactured at Rocky Mountain Arsenal, Colorado, between 1961 and 1965, and the VX rockets were manufactured at Newport Army Ammunition Plant, Indiana, in 1964 and 1965. The M55 was shown to be erratic and undependable, and the Army declared it obsolete in 1981 (3, 4).

In the risk analysis for different transportation options at the eight U.S. CW storage sites (which assumed that incineration would be the destruction method; described more fully in appendix B), a large portion of the risk often was due to the presence of specific munitions(5). For example, the M55 rockets are stored at the Anniston (Alabama), Lexington-Blue Grass (Kentucky), Pine Bluff (Arkansas), Tooele (Utah), and Umatilla (Oregon) Army depots (6). At Anniston, with the option of continued CW storage and with the adoption of appropriate safety procedures, more than 40 percent of the remaining risk was associated with the M55 rockets (5). (The balance of the remaining risk is distributed among the other types of munitions.)

For on-site disposal with adoption of appropriate safety procedures at the Lexington-Blue Grass Army Depot, rockets are responsible for essentially all of the risk. At Pine Bluff, for on-site destruction with adoption of appropriate safety procedures, more than 95 percent of the risk is due to the M55 rockets. At the Tooele site, most of the risk is associated with bulk containers of agent GB in warehouses, although handling projectiles, rockets, and mines with VX is also a contributing factor. At the Pueblo facility, which lacks M55 rockets, the on-site destruction alternative with adoption of appropriate safety procedures has most of the risk associated with the projectile munitions.

The M55 rocket contains a chemical agent (either VX or GB), in an aluminum warhead a rocket motor with a solid propellant; a burster loaded with an explosive to explode the warhead on impact and disseminate the agent; an igniter to ignite the rocket motor; and a fuse designed to arm after rocket launch and to detonate the burster on striking the ground (3, 4). Leaks or other degradation of any of these systems over time could lead to an increased risk of accident. In 1985 the U.S. Army Material Systems Analysis Activity (AMSAA) conducted a study on the condition of the M55 stockpile in which 393 rockets were selected randomly from the total stockpile of 478,000 (3, 4). These rockets were disassembled and the individual components assessed to estimate the amount of

Figure 1-1—M55 Rocket, Filled With Agent GB or VX

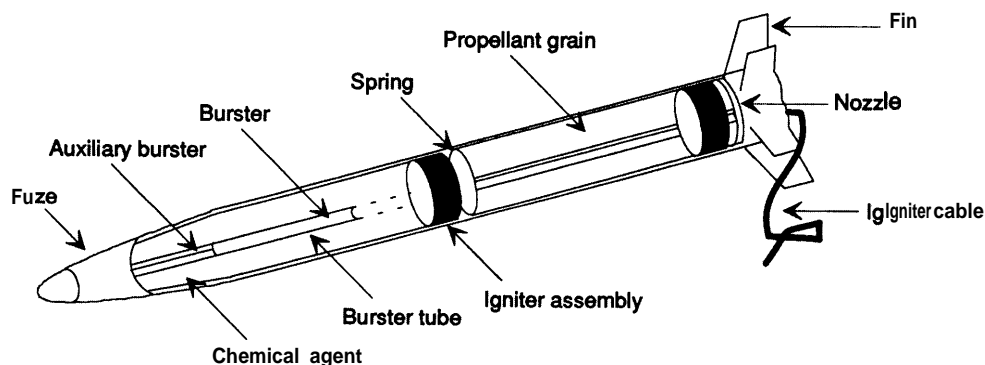

SOURCE: U.S. Department of the Army, "Independent Evaluation/Assessment of Rocket, 115mm: Chemical Agent (GB or VX), M55," U.S. Army Material Systems Analysis Activity, Aberdeen Proving Ground, MD, October 1985.

(Continued on next page)

Box 1-C-Condition of the M55 Rockets-Continued

degradation they had undergone after 20 to 25 years of storage. These estimates were presented as a means to estimate the continued storability of the rockets and were not considered accurate predictions.

Both external and internal leaks of chemical agents in the M55 rockets were found. The rocket propellant contains a stabilizer that was present at 1.6 to 2.2 percent by weight. If the stabilizer content, which is depleted during normal conditions, falls below 0.2 percent then auto ignition of the propellant could occur. The stabilizer has probably been diminishing ever since the weapons were manufactured, but because the 1985 assessment was the first evaluation since production, it was impossible to quantify stabilizer degradation over time. A worst-case estimate of remaining storage life, obtained by projecting stabilizer loss for the lot showing the greatest decrease since production (stored at Johnston Island), indicated that this lot would reach the "first decision point (increased surveillance)" after 25 years, in 2010. Overall, the propellant was estimated to show a minimal loss of stabilizer, which indicates an extensive remaining safe storage life. Other potential hazards identified in this project included interaction between internally leaking GB agent and the burster agent to produce a highly sensitive organometallic compound, although, "unless the reactions are highly efficient, sufficient amounts of the metal organic compounds [to cause an explosion] are not expected." Metal springs that keep the fuse in an unarmed position may be corroded by internally leaking GB, causing the fuse to become armed and able to function during a handling accident. However, the study concluded that, overall, the occurrence of a catastrophic event with the M55 rocket in the near future is highly unlikely (3, 4).

Overall, the rocket stockpile was estimated to be in good condition by the Army's 1985 study. The Army has established a continued monitoring program to monitor degradation and rapidly identify new leakers (6). Although M55 rockets containing agent GB were first found to be leaking in 1966 (3, 4), there has been no trend toward an increased rate of leakers detected (7). At the Kentucky Blue Grass facility, as is routine at all U.S. CW storage facilities, air in igloos containing M55 rockets and other CW munitions is monitored for chemical agent prior to entry. The M55 rockets are stacked on wooden pallets with 15 rockets per pallet. A positive igloo detection of CW agent requires that the individual leaking rocket be located. Individual rockets, sealed in their fiberglass firing tubes, are also routinely tested for leaks. Leaking rockets are transferred to steel tubes that are bolted together and sealed at the middle with a flange and rubber "O" ring. However, only 897 individual rockets are monitored per quarter, out of a total of 69,500 at the Kentucky base (1.3 percent per quarter). Very few munitions other than the rockets have leaked at this facility (7). Although it is difficult to support conclusions made from data taken from the limited sample sizes used in these studies, the Army has found no trends in the frequency of leak detection in M55 rockets over time.

References

1. **Mitre Corp.**, McLean, VA, "Risk Analysis Supporting the Chemical Stockpile Disposal Program (CSDP)," prepared for the Office of the Program Manager for Chemical Demilitarization, U.S. Army, Aberdeen Proving Ground, MD, December 1987.
2. National Research Council, *Disposal of Chemical Munitions and Agents* (Washington, DC: National Academy Press, 1984).
3. McKenna, W., U.S. Army Armament, Munitions and Chemical Command, Defense Ammunition Directorate, Air, Sea and Toxic Chemical Munitions, Rock Island, IL, personal communication, Dec. 2, 1991.
4. U.S. Department of the Army, "Independent Evaluation/Assessment of Rocket, 115mm: Chemical Agent (GB or VX), M55," U.S. Army Material Systems Analysis Activity, Aberdeen Proving Ground, MD, October 1985.
5. Mitre Corp., McLean, VA, "Risk Analysis Supporting the Chemical Stockpile Disposal Program (CSDP)," prepared for the Office of the Program Manager for Chemical Demilitarization, U.S. Army, Aberdeen Proving Ground, MD, December 1987.
6. U.S. Department of the Army, "Chemical Stockpile Disposal Program Final Programmatic Environmental Impact Statement," vols. 1,2,3, Office of the Program Manager for Chemical Demilitarization, Aberdeen Proving Ground, MD, 1988.
7. Briefing to Office of Technology Assessment staff at the Lexington-Blue Grass Army Depot. Lexington, KY, Dec. 10, 1991.

state-of-the-art of alternatives we were able to examine and of showing the level of information that exists about alternatives. If a program to develop alternatives was pursued, these four may or may not be among those selected for further tests.

Present work with alternative technologies is focused on treatment of hazardous wastes other than chemical weapons. None of these techniques is available at present as a working alternative to the Army's current disassembly-incineration program. Moreover, it is not possible, on the basis of information currently available, to predict which alternative technique, if any, would be the best candidate for development into an acceptable and successful CW disposal technology. If the Army's present program does not succeed, there could well be advantages in supporting the development of more than a single CW destruction technology both to encourage competition and to ensure that at least one of them will be successful. There may also be advantages to certain technologies that are unique to specific sites.

Market forces alone cannot be expected to lead the development of alternative CW destruction technologies. The U.S. stockpile of chemical weapons is small compared to industrial chemical waste. If an alternative is to be developed, government will have to be depended on for at least some of the support. There are existing programs at the Federal and State level and in private industry and universities that are designed to promote alternative technologies for hazardous waste disposal. These might serve as models for development of alternative technologies for chemical weapons disposal, although none has been given this mission (see box I-D).

In developing alternative programs, a clearly defined process and definition for judging them will be required. Even though difficult, failure to establish applicable criteria for assessing alternative programs will make it impossible to gauge their success or to make necessary corrections.

For example, the limited scope of the Army's current technology demonstration project at Johnston Island was criticized in a 1991 NRC Letter

Box I-D—Programs for the Promotion of Alternative Technologies for Hazardous Waste Destruction

Existing programs designed to promote alternative technologies for hazardous waste disposal may serve as models for the development and promotion of alternative technologies for chemical weapons disposal. State and Federal Government, private industry, and universities have developed programs that attempt to address the technical, legal, and social obstacles involved with the development and introduction of new technologies for the disposal of hazardous waste. For example, a workshop at the annual meeting sponsored by the National Solid Wastes Management Association is titled, "Dealing With an Angry Public: Siting Strategies To Gain Public Acceptance." Topics include how to define realistic, measurable public acceptance goals; analysis of key audiences; identification and mobilization of grass-roots support; and implementation of cost-effective strategies and monitoring their success while building public acceptance (1).

The Technology Innovation Office (TIO) in the U.S. Environmental Protection Agency (EPA) Office of Solid Waste and Emergency Response has the mission of identifying and publicizing more efficient, cost-effective solutions from developers and technology users that address hazardous waste disposal problems faced by the Federal Government and private sector. The TIO mission includes promoting the use of innovative treatment technologies by government and industry on contaminated waste sites, soils, and groundwater by providing technology and market information to targeted audiences of Federal agencies, States, consulting engineering firms, technology developers, and the investment community (2). TIO also attempts to facilitate the cooperative development, evaluation, and implementation of innovative treatment alternatives at Federal facility sites (3). They have compiled a list of resources for alternative technology development including regional ERA offices that deal with permitting and performance standards; Federal and State assistance programs; Federal, State, nonprofit, and private test and evaluation facilities; and university affiliated hazardous waste research centers (4). EPA's Office of Research and Development (ORD) also plays a role in alternative technology development by helping vendors develop and test, at both pilot and full scale, technologies that may be applicable to U.S. waste site remediation, through such programs as the Superfund Innovative Technology Evaluation (SITE) program (5). The SITE includes a demonstration program that funds developers through a cost-sharing process in which developers pay for the

(Continued on next page)

**Box I-D—Programs for the Promotion of Alternative
Technologies for Hazardous Waste Destruction-Continued**

mobilization and operation of technology demonstrations and EPA pays for the planning, sampling, analysis, quality assurance, and report preparation. SITE's Emerging Technologies Program, with currently more than 30 participants, funds up to \$300,000 over 2 years for bench or pilot technology development.

The National Environmental Technology Applications Corporation (NETAC), has a similar mission of accelerating, on a national basis, the commercialization of environmental technologies under development by the public and private sectors (6, 7). This not-for-profit corporation was established through a cooperative agreement between EPA and the University of Pittsburgh Trust, specifically for the purpose of developing innovative commercial environmental technologies. This program reaches across all of the EPA programs described above, in addition to the private sector. NETAC offers a variety of services to the environmental technology developer, supplier, end user, and government official. Services include business planning, market and financial analysis, entry strategy, technology evaluation, laboratory services, and regulatory analysis.

References

1. National Solid Wastes Management Association, "Waste Expo '92," New Orleans, LA, May 5-8, 1992.
2. U.S. Environmental Protection Agency, Office of Solid Waste and Emergency Response, Technology Innovation Office, Mission Statement, Washington, DC.
3. Powell, D.M., and Kovalick Jr., W.W., "Innovative Treatment Technologies: A New Forum for Cooperation," paper submitted to "Federal Environmental Restoration 1992," U.S. Environmental Protection Agency, Office of Solid Waste and Emergency Response, Technology Innovation Office, January 1992.
4. U.S. Environmental Protection Agency, Office of Solid Waste and Emergency Response, Technology Innovation Office, "Innovative Hazardous Waste Treatment Technologies: A Developer's Guide To Support Services," EPA 540/2-91/012, Washington, DC, June 1991.
5. Kovalick, Jr., W.W., "Innovative Site Remediation Technologies: Barriers and Opportunities," paper presented at the "Symposium on Global Environment and the Construction Industry," Massachusetts Institute of Technology, Cambridge, MA, Oct. 21, 1991.
6. Letter from Sharon L. Ross, Business Analyst, NETAC, University of Pittsburgh Applied Research Center, Pittsburgh, PA, Apr. 28, 1992.
7. Berkey, Edgar, President, National Environmental Technology Applications Corp. (NETAC), Pittsburgh, PA, Written comments received Apr. 15, 1992.

Review. The NRC pointed out that the Army was missing the opportunity to provide crucial assessments of the technology and program that would support the construction of future sites by generating higher levels of public confidence. The NRC also stated that the success of any demonstration project should be gauged by the degree to which it facilitates public understanding and acceptance by providing well-documented answers to reasonable, and probably inevitable, questions from concerned citizens as well as regulators. For example, a failure of the current demonstration is that it does not require measurement of products of incomplete combustion (PICs), especially dioxins and dibenzofurans (13). The Clean Air Act does not apply to the Johnston Atoll Chemical Agent Disposal System (JACADS) facility and therefore the Army is not collecting data to demonstrate compliance with this act, but the

continental sites are covered by the Clean Air Act and the relevant States will need this type of information.

International Implications

A successful U.S. CW disposal program will have broad international implications. The United States and the C.I.S. are setting the stage for worldwide CW disposal. A United Nations special commission is currently investigating possible methods for the destruction of the Iraqi CW stockpile. As many as 18 countries in addition to the United States and the C.I.S. may now possess chemical weapons. With increasing international pressure to eliminate chemical weapons, the need for an appropriate and acceptable CW program also increases. This pressure also makes it difficult to discuss delays of any

type. If any alternative technology development program is supported, it will be necessary to bring all of these considerations into the decision. This OTA background paper provides only some of the information about the potential benefits and risks that alternative technologies could offer. It is not clear at this point whether benefits exceed the risks, but directed development work on alternatives could help answer some of the key technical questions.

CHAPTER 1 REFERENCES

1. National Research Council, *Disposal of Chemical Munitions and Agents* (Washington, DC: National Academy Press, 1984).
2. Whelen, R. P., Engineering and Technology Division, briefing at the Office of the Program Manager for Chemical Demilitarization, Aberdeen, MD, Oct. 29, 1991.
3. U.S. Congress, Library of Congress, Congressional Research Service, "Chemical Weapons: U.S. Arms Control Negotiations and Destruction," prepared by Steven R. Bowman, Washington, DC, updated Sept. 25, 1991 and Feb. 13, 1992.
4. Baronian, C., Deputy Program Manager and Technical Director, briefing at the Office of the Program Manager for Chemical Demilitarization, Aberdeen, MD, Oct. 29, 1991.
5. Busbee, W.L., briefing at the National Research Council Committee on Review and Evaluation of the Army Chemical Stockpile Disposal Program, Washington, DC, Jan. 21, 1992.
6. Livingstone, S., Assistant Secretary of the Army (Installations, Logistics and Environment), testimony before the House Committee on Appropriations, Subcommittee on Defense, Apr. 1, 1992, Second Session, 102d Congress.
7. Ember, L., "Chemical Weapons Disposal: Daunting Challenges Still Ahead," *Chemical and Engineering News*, **68(33):9-19**, Aug. 13, 1990.
8. Chemical and Engineering News, "Russia Not Able To Destroy Chemical Arms," *Chemical and Engineering News* **70(3):17**, Jan. 20, 1992.
9. U.S. Congress, General Accounting Office, *Stockpile Destruction Delayed at the Army's Prototype Disposal Facility*, GAO/NSIAD-90-222 (Washington, DC: July 1990).
10. U.S. Congress, General Accounting Office, *Obstacles to the Army's Plan To Destroy Obsolete U.S. Stockpile*, GAO/NSIAD-90-155 (Washington, DC: May 1990).
11. U.S. Congress, General Accounting Office, *Stockpile Destruction Cost Growth and Schedule Slippages Are Likely To Continue*, GAO/NSMD-92-18 (Washington, DC: November 1991).
12. Mitre Corp., McLean, VA, "Evaluation of the GB Rocket Campaign: Johnston Atoll Chemical Agent Disposal System Operational Verification Testing," prepared for the Office of the Program Manager for Chemical Demilitarization, U.S. Army, Aberdeen Proving Ground, MD, June 1991.
13. National Research Council, Committee on Review and Evaluation of the Army Chemical Stockpile Disposal Program, "Review of the Mitre Report: Evaluation of the GB Rocket Campaign: Johnston Atoll Chemical Agent Disposal System Operational Verification Testing, Dated May 1991," letter report, Washington, DC.
14. Hudson, V., Deputy Commissioner for Special Projects, Kentucky Department for Environmental Protection, Frankfort Office Park, Frankfort, KY, personal communication, Dec. 12, 1991; letter review, Apr. 15, 1992.
15. Briefing of Office of Technology staff at the Lexington-Blue Grass Army Depot, Lexington, KY, Dec. 10, 1991.
16. McKenna, W., U.S. Army Armament, Munitions and Chemical Command, Defense Ammunition Directorate, Air, Sea and Toxic Chemical Munitions, Rock Island, IL, personal communication, Dec. 2, 1991.
17. U.S. Department of the Army, "Independent Evaluation/Assessment of Rocket, 115mm: Chemical Agent (GB or VX), M55," U.S. Army Material Systems Analysis Activity, Aberdeen Proving Ground, MD, October 1985.

The Army's Chemical Weapons Disposal Program

THE U.S. ARMY'S CHEMICAL WEAPONS STOCKPILE

Geography and Distribution

The chemical weapons (CW) stockpile is located on Army bases at eight continental U.S. sites (see figure 2-1) and at Johnston Island in the Pacific Ocean (717 nautical miles southwest of Hawaii). It is distributed as follows (by percentage of chemical agent):

Site location	Percentage of total
Tooele Army Depot, UT,.....	42.3
Pine Bluff Arsenal, AR.....	12.0
Umatilla Depot, OR.....	11.6
Pueblo Depot, CO.....	9.9
Anniston Army Depot, AL.....	7.1
Johnston Island, South Pacific.....	6.6
Aberdeen Proving Ground, MD.....	5.0
Newport Army Ammunition Plant, IN.....	3.9
Lexington-Blue Grass Army Depot, KY.....	1.6

The stockpile includes chemical agents stored in bulk containers without explosives and propellants, as well as rockets, land mines, mortars, cartridges,

Figure 2-1—U.S. Chemical Weapons Stockpile Distribution

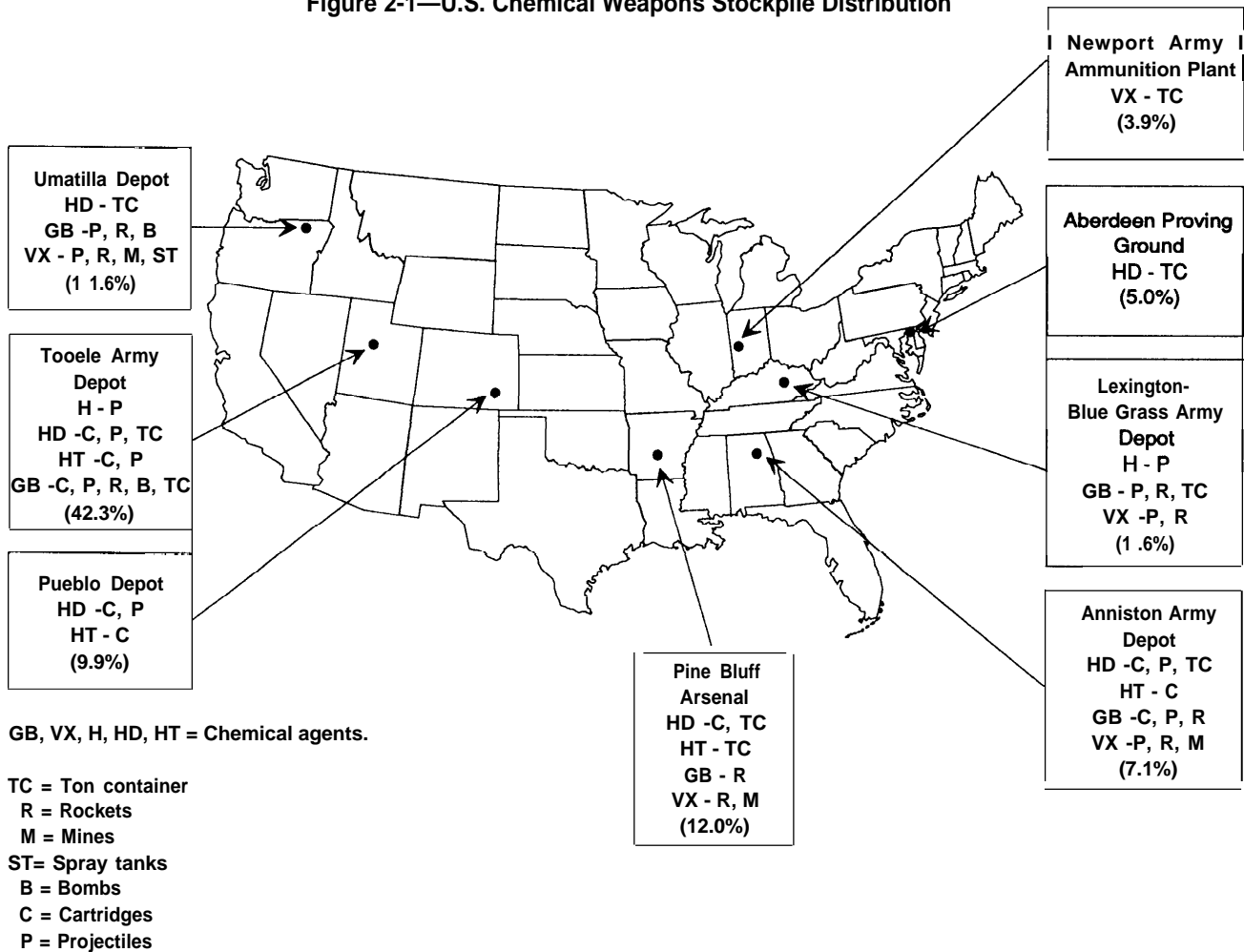

SOURCE: U.S. Department of the Army, "Chemical Stockpile Disposal Program Final Programmatic Environmental Impact Statement," vols. 1,2,3, Office of the Program Manager for Chemical Demilitarization, Aberdeen Proving Ground, MD, 1988.

Table 2-I-Characteristics of Chemical Agents

Agent	Common name	CAS No. ^a	Chemical name	Chemical formula	Vapor pressure torr (at 25° C)	Liquid density g/cm ³ (at 25° C)	Freezing point (°C)	Color	Mode of action
<i>Nerve</i>									
GA	Tabun	77-81-6	Ethyl-N, N-dimethyl phosphoramidocyanidate	C ₆ H ₁₁ N ₂ O ₂ P	0.07	1.073	-50	Colorless to brown	Nervous system poison
GB	Sarin	107-44-8	Isopropyl methyl phosphonofluoridate	C ₄ H ₁₀ FO ₂ P	2.9	1.089	-56	Clear to straw to amber	Nervous system poison
VX		50782-69-9	o-ethyl-S-(2-diisopropylaminoethyl) methyl phosphonothio-late	C ₁₁ H ₂₆ N ₂ O ₂ PS	0,0007	1.008	<-51	Clear to straw	Nervous system poison
<i>Vesicant</i>									
H, HD	Mustard	505-60-2	Bis(2-chloromethyl)sulfide	C ₄ H ₈ Cl ₂ S	0.08 ^b (H) 0.11 (HD)	1.27	8-12 (H) 14 (HD)	Amber to dark brown	Blistering of exposed tissue
HT	Mustard		60% HD and 40% T ^c		0.104	1.27	1	Amber to dark brown	Blistering of exposed tissue
L	Lewisite	541-25-3	Dichloro(2-chlorovinyl)arsine	C ₂ H ₂ AsCl ₃	0.58	1.89	-18 ^d	Amber to dark brown to black	Blistering of exposed tissue

^a Chemical Abstracts Service number.

^b Varies with purity of sample.

^c Agent T is Bis[2(2-chloroethyl-thio)ethyl]ester; it is CAS No. 63918-89-8.

^d Varies ± 0.1° C, depending on purity and isomers present.

SOURCE: U.S. Department of the Army, "Chemical Stockpile Disposal Program Final Programmatic Environmental Impact Statement," vols. 1,2,3, Office of the Program Manager for Chemical Demilitarization, Aberdeen Proving Ground, MD, 1988.

and artillery projectiles composed of both chemical agent and various explosive-propellant components.

The total amount of chemical agents contained in the stockpile has been estimated to be 25,000 tons (1, 2), although the exact amount is classified. The chemical weapons contain organophosphorus nerve agents (GA, GB, and VX) or vesicant compounds (mustard and Lewisite) (table 2-1). (See box 2-A on the toxic properties of these compounds.) These

chemical agents are "unitary" in that they are directly toxic to humans, as opposed to "binary" agents, which are relatively nontoxic until they are mixed together. Although the exact amount of binary weapons in the U.S. stockpile is classified, it has been described by the House Committee on Appropriations as "negligible" (3).

Most (61 percent) CW agents are not contained in munitions but stored in steel 1-ton bulk containers

Box 2-A—Properties of Chemical Weapons Agents

Chemical weapons agents stored at the eight continental U.S. Army sites include both organophosphorus ester nerve agents and mustard blister (vesicant) agents.

Mustards. The sulfur mustards in the U.S. Army stockpile are blister (vesicant) agents H, HD, HT, and Lewisite (table 2-1). Agent H typically contains about 30 percent related impurities (1), but in some cases may contain only 18 percent of the nominal material. The impurity of some of these materials makes monitoring and confirming their destruction by certain proposed technologies, such as chemical neutralization, more difficult (2). HD and HT are purified by washing or distillation. Lewisite is a more volatile organic arsenic-based vesicant compound (1).

Human exposure to vesicants leads to blistering of exposed tissue and can cause severe skin blisters, injury to the eyes, and damage to the respiratory tract from inhalation of vapors (1). Epidemiological data indicate that agent H is a human carcinogenic, and T (in HT) and Lewisite are probably carcinogens (3,4, 5).

Nerve Agents. The three nerve agents in the U.S. Army CW Stockpile are GA (Tabun), GB (Sarin), and VX (figure 2-2). They are normally liquids at room temperature but are highly toxic both as liquids or following vaporization (see table 2-1). Structurally related organophosphorus ester compounds having less acute human toxicity are used as insecticides. These compounds are potent inhibitors of acetylcholinesterase (AChE), an enzyme

that normally breaks down the neurotransmitter acetylcholine. With AChE inhibited, acetylcholine builds up to abnormal levels, causing a continuous, uncontrolled stimulation of nerves that use this neurotransmitter. Among other characteristic poisoning symptoms from AChE inhibition are convulsions, with death in mammals caused by respiratory failure. Death from these nerve agents can occur within 10 minutes of exposure (1). None of the nerve agents is apparently carcinogenic, mutagenic, or teratogenic. In one review, nerve degeneration was considered an unlikely outcome from either acute or chronic exposure to these nerve agents (5).

References

1. U.S. Department of the Army, "Chemical Stockpile Disposal Program Final Programmatic Environmental Impact Statement," vols. 1,2,3, Office of the Program Manager for chemical Demilitarization, Aberdeen Proving Ground, MD, 1988.
2. Whelen, R.P., Engineering and Technology Division, briefing at the Office of the Program Manager for Chemical Demilitarization, Aberdeen, MD, Oct. 29, 1991.
3. U.S. Department of Health and Human Services, National Toxicology Program, Fourth Annual Report on Carcinogens, NTP 85-002, Washington, DC, 1985.
4. International Agency for Research on Cancer, Monograph 9, pp. 181-192, Geneva, Switzerland, 1975.
5. Journal of the American Medical Association, "Recommendations for Protecting Human Health Against Potential Adverse Effects of Long-term Exposure to Low Doses of Chemical Warfare Agents," *Journal of the American Medical Association*, 259(10):1453, 1459, Mar. 11, 1988.

Figure 2-2-Structures of Chemical Weapons Nerve (Organophosphorus) and Blister (Mustard) Agents

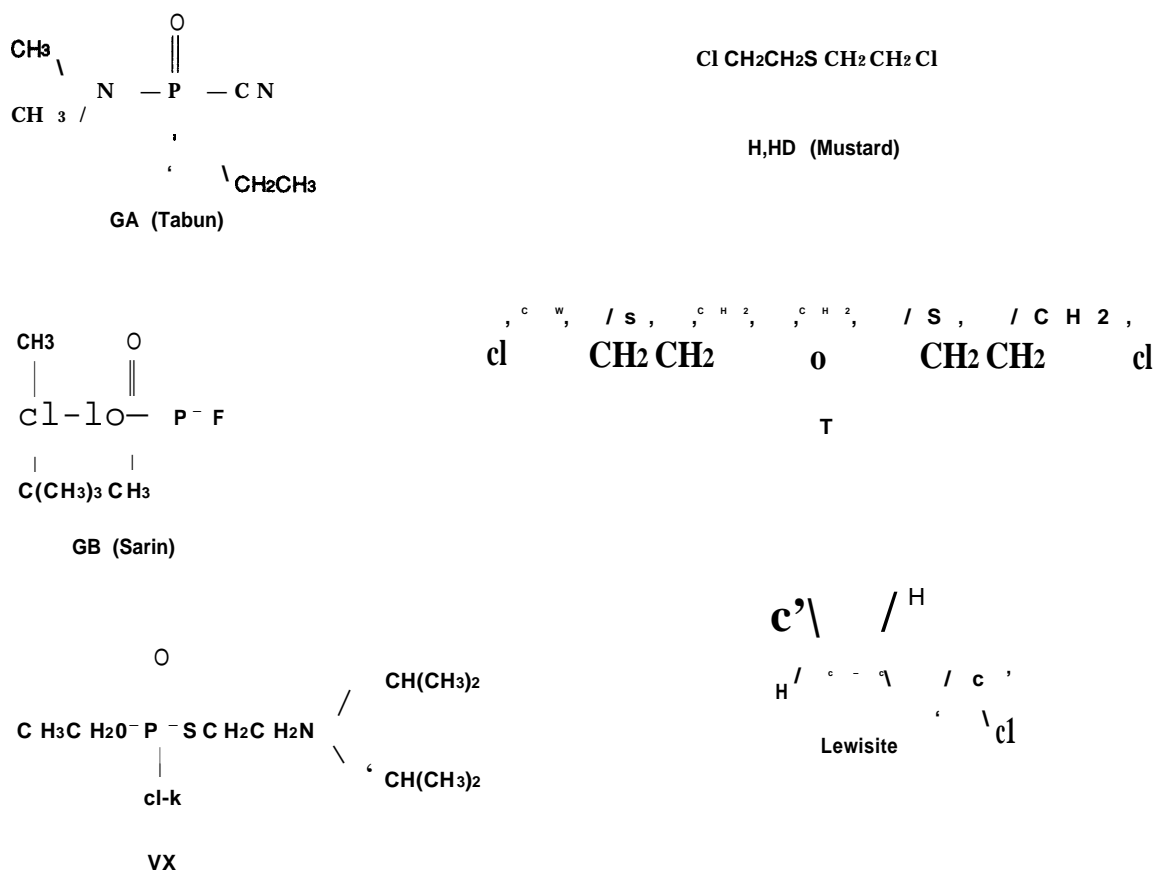

SOURCE: U.S. Department of the Army, "Chemical Stockpile Disposal Program Final Programmatic Environmental Impact Statement," vols. 1,2,3, Office of the Program Manager for Chemical Demilitarization, Aberdeen Proving Ground, MD, 1988.

Table 2-2—Physical Characteristics of Chemical Munitions

Munitions type ^a	— Physical data —			— Agent —		Explosive/energetic components		
	Length (in)	Diameter	Weight (lb) ^b	Type	Weight (lb) ^b	Burster	Propellant	Fuze
Rocket								
M55	78.0	115 mm	57	GB	10.7	Yes	Yes	Yes
M55	78.0	115 mm	56	Vx	10.0	Yes	Yes	Yes
Land mine								
M23	5.0	13.5 in	23	VX	10.5	Yes	No	Yes ^c
155-mm projectile								
M104	26.8	155 mm	95	HD	11.7	Yes ^d	No	No
M110	26.8	155 mm	99	H	11.7	Yes ^d	No	No
M110	26.8	155 mm	99	HD	11.7	Yes ^d	No	No
M121, M121A1, M122	26.7	155 mm	100	GB	6.5	Yes ^d	No	No
M121A1	26.7	155 mm	100	VX	6.0	Yes ^d	No	No
105-mm projectile								
M60	21.0	105 mm	32	HD	3.0	Yes ^d	Yes ^e	Yes ^c
M360	16.0	105 mm	32	GB	1.6	Yes ^d	Yes ^e	Yes ^c
8-in projectile								
M426	35.1	8 in	199	GB or VX	14.5	Yes ^d	No	No
4.2-in mortar								
M2, M2A1	21.0	4.2 in	25	HT	5.8	Yes	Yes	Yes
M2, M2A1	21.0	4.2 in	25	HD	6.0	Yes	Yes	Yes
500-lb bomb								
MK-94-O	60	11 in	441	GB	108	No	No	No
750-lb bomb								
MC-1	50	16 in	725	GB	220	No	No	No
M4teye bomb								
MC-1	86	14 in	525	GB	347	No	No	No
Spray tank								
TMU-28/B	185	22.5 in	1,935	VX	1,356	No	No	No
Ton container								
	81.5	30.1 in	3,100	H, HD, HT, or L	1,700	No	No	No
	81.5	30.1 in	N/A ^f	GA	N/A ^f	No	No	No
	81.5	30.1 in	2,900	GB	1,500	No	No	No
	81.5	30.1 in	3,000	Vx	1,600	No	No	No

^a Military designation numbers are shown below the munitions type.

^b For conversion of the U.S. military standard sizes to metric units, 1 in = 2.54 cm and 1 lb = 0.454 kg.

^c Land mines and fuzes are stored together but are not assembled.

^d Not all projectiles have been put into explosive configurations.

^e The 105-mm projectile is configured both with and without bursters, fuzes, and cartridge cases containing propellant.

^f Information is not available.

SOURCE: U.S. Department of the Army, "Chemical Stockpile Disposal Program Final Programmatic Environmental Impact Statement," vols. 1,2,3, Office of the Program Manager for Chemical Demilitarization, Aberdeen Proving Ground, MD, 19SS.

(4). However, most of the individual items to be destroyed in the stockpile are the various munitions described in table 2-2.

History of Chemical Weapons Disposal

The Army has an ongoing need for disposal of surplus and obsolete chemical weapons. Attempts to manage the problems of CW disposal have a long history involving a variety of destruction techniques. Prior to 1969, the Army disposed of chemical weapons by open-pit burning, evaporative "atmospheric dilution," burial, and placement of muni-

tions in concrete coffins for ocean dumping (5, 6). During the decades of experience with CW disposal, although Army personnel have been exposed to CW agents, no casualties have resulted (7).

In 1969 at the request of the U.S. Department of Defense (DOD), the National Research Council (NRC) reviewed the issue of CW disposal and recommended chemical neutralization via alkaline hydrolysis for the nerve agent GB and incineration for the mustard agents H and HD (6). After research and development work by the Army in the 1970s on these technologies, the Army concluded that inciner-

ation was the preferred method for the destruction of all classes of chemical weapons.

The Army indicated that the decision to abandon chemical neutralization in favor of incineration (officially in 1982) resulted from problems encountered with the chemical neutralization process (6). The Army's early chemical neutralization program actually applied only to destruction of the chemical agent itself. Incineration was used to decontaminate metal parts containing residual chemical agent that came from disassembled CW munitions and storage containers. Since incineration was introduced as a necessary component of all early CW disposal schemes, the fact that it became the basis of the Army's CW disposal program was probably inevitable. The 1987 report by the Army about its experience with CW destruction refers to the "widespread acceptance of incineration as an effective, safe, and environmentally sound method of disposal of hazardous materials" (6). Now, 5 years later, the suggestion of widespread acceptance of incineration seems insupportable in light of the strong and effective opposition to most applications of incineration for waste disposal.

In 1984 the incineration decision was supported by another NRC review. The NRC based its endorsement on a review of existing data supplied almost entirely by Army research. In 1988 the Army published a Final Programmatic Environmental Impact Statement (PEIS) designating on-site disposal consisting of disassembly followed by incineration as the preferred method of CW destruction (4).

On-Site Destruction vs. Relocation of the CW Stockpile for Off-Site Destruction

In the 1988 PEIS for its on-site CW disassembly and incineration program, the Army compared several alternatives, including partial or complete relocation of the CW stockpile to regional or national sites for destruction. The comparative risk of the entire CW disposal program associated with on-site versus regional disposal was evaluated as not statistically distinguishable according to an analysis contracted by the Army (7). The Army argued that this apparent risk equivalence was misleading because the analysis failed to consider the location in terms of corresponding mitigation of possible accidents. That is, an accident on an existing Army base would be easier to mitigate than an accident occurring at some unknown point along a transporta-

tion corridor. A qualitative consideration of this difference led to the conclusion that *any* option involving CW transportation off-site was more risky (7). The current Army program specifies that chemical weapons will remain on-site, at the eight continental U.S. bases and Johnston Island where they are now located, for destruction by disassembly and incineration.

Condition of the CW Stockpile— Potential of Increased Risk From CW Deterioration

In 1992, chemical weapons containing unitary agents stored in the continental United States will be from 24 to 47 years old (8). Low-level leaks of agents have been detected in some of the munitions, although the risk from such leaks has been suggested to be low. The M55 rockets (box I-C) filled with GB agent are the greatest source of leaks. All other types of munitions and storage containers in the CW stockpile have substantially fewer leakages and are in stable condition (4, 5, 9, 10). The relative instability of the M55 rocket is probably due to its unique construction, which includes a thin aluminum warhead filled with GB chemical agent (7, 10, 11). The other agent-filled munitions are constructed of much heavier gauge aluminum plate or steel that is more resistant to corrosion and leakage. Most of the leaking M55 rockets, first discovered in 1966, come from one manufacturing source of GB agent, and there appears to be a correlation between acid content and frequency of leakage through the aluminum walls (7, 10, 11, 12).

Primarily because of leakage problems, the M55 rockets constitute a major portion of the total risk of CW handling and storage at the five continental U.S. sites where they are located (12). The CW monitoring program directs Army personnel to conduct ongoing surveillance of the stockpile. The Army has established a continuous monitoring program to rapidly identify new leaking munitions (4). As leaking munitions are discovered, they are sealed in protective steel tubes ("overpacks") to contain further leakage. Although M55 rockets containing agent GB were first found to be leaking in 1966(11, 12), there has been no trend toward an increased rate of leakers detected (9).

In a partial answer to questions about the urgency of CW disposal, the NRC committee in its 1984 report stated that data are insufficient to project the

near- or long-term storage life of CW agent containers. However, in the face of this uncertainty, available information indicates that the frequency of leaks for most munitions at all eight U.S. sites, except for the M55 rockets, did not increase substantially in the years prior to (5) or after 1984 at at least the Lexington-Blue Grass Army Depot in Kentucky (9). A 1985 study by the Army specifically on the condition of the M55 rockets concluded that the occurrence of a catastrophic event in the near future is "highly unlikely" (11, 12). However, in view of the critical importance of this issue, this study could be updated.

DISPOSAL OF THE ARMY'S CW STOCKPILE

The Army's Demonstration Projects

The Army's current program requires a series of pilot demonstration CW disposal facilities. Some of these demonstrations have been required by Congress. The Chemical Agent Munitions Disposal System (CAMDS) (Tooele, Utah) was initiated by the Army to test and evaluate equipment and processes to be used in CW disposal facilities. Although CAMDS is authorized to dispose of chemical weapons, its primary purpose is data collection and test evaluation of the process equipment (13).

The Johnston Atoll Chemical Agent Disposal System (JACADS) is currently undergoing operational verification and testing for the destruction of M55 rockets. The Army anticipates that JACADS will eventually demonstrate the destruction of all types of CW munitions and storage containers. This system is actually not one but four separate incinerator systems, each designed to handle a distinct component from the CW disassembly waste stream. Public Law 100-456 (the National Defense Authorization Act of Fiscal Year 1989) requires the Army to complete operational verification of its technology at JACADS before proceeding with equipment tests at Tooele, Utah, and other U.S. sites (14). Based in part on the CAMDS experience, this "new generation" of CW incinerators is intended to demonstrate compliance with current Toxic Substances Control Act (TSCA) and Resource Conservation and Recovery Act (RCRA) standards. TSCA compliance is required because the tube containers for M55 rockets contain small amounts of polychlorinated biphenyls (PCBs). RCRA compliance is similar for any new

incinerator and involves demonstrating acceptable emission rates of metals in ash, particulate loading, hydrogen chloride and hydrogen fluoride stack emissions, etc. (See box 2-B on regulatory hurdles for CW incineration facilities.) Results from this technology demonstration design facility are intended for use as a basis for the design and construction of the eight proposed continental U.S. on-site incinerators, although construction at Tooele, Utah has already begun.

Four evaluations of the JACADS operation by the Mitre Corp. have been planned for completion by 1993. The frost report was released in June 1991 (14). A final evaluation directed to Congress, followed by congressional certification of JACADS, is anticipated in February 1993 (15).

DIFFICULTIES ENCOUNTERED BY THE CURRENT CW DISPOSAL PROGRAM

Local and National Opposition

Several national and local organizations are opposed to the Army's present CW disposal program. Citizens at the Lexington-Blue Grass Army Depot (Kentucky) have mounted the most effective resistance. The opposition to the Army's CW destruction program in Kentucky may be able to block or seriously delay its completion. (See box 1-B for a description of Kentucky State authority for regulating hazardous waste facilities.)

Currently, less opposition exists at other continental U.S. sites (16). However, other States might follow Kentucky's lead. The Utah State legislature has implemented some restrictive requirements for CW disposal facilities proposed for the Tooele site. Specifically, it has required a series of additional and time-consuming test burns. Citizen groups that oppose the Army's current CW destruction plan also exist in every one of the eight states with CW stockpiles.

Although the public was not informed of the Army's plans to build a CW destruction facility at the Lexington-Blue Grass Army Depot until January 1984, citizen concerns about the CW storage had been developing for decades. Although the Army moved chemical weapons into the Lexington-Blue Grass Army Depot during the 1950s, local residents were not informed of this fact until 10 years later.

Box 2-B—Some Regulatory Hurdles for CW Destruction

The Army must secure environmental permits for its CW incineration facilities in the same manner as civilian projects. The Army's Johnston Atoll Chemical Agent Disposal System (JACADS) demonstration facility, located on Johnston Island, however, is exempt from obtaining certain environmental permits that will be required for CW destruction facilities planned for the continental United States. Although Executive Order 12088 provides for waivers of these laws in cases of national emergency, the Army has not yet requested such a waiver for the storage and handling of chemical weapons. A range of Federal, State, and local permits required prior to the start of construction include:

1. A review by the Department of Health and Human Services of public health and safety issues and the environmental impact of the Army's CW destruction program (I).
2. Resource Conservation and Recovery Act (RCRA) permits for construction and for operation of incinerator facilities. Full-scale incinerator operations cannot begin until trial burns are satisfactorily completed, following construction approval, in accordance with final RCRA permitting requirement. The U.S. Environmental Protection Agency (EPA) has delegated RCRA authority to all of the eight States in which incinerators are planned.
3. Toxic Substances Control Act approval before operation of incinerators with M55 rockets, because of the presence of PCBs in rocket-firing tubes.
4. Air emissions source permits under the Clean Air Act and State or local air quality regulations. Clean air permits must be obtained from each relevant State authority.
5. Other environmentally oriented regulations including the Endangered Species Act (Public Law 93-205), Floodplain Management Executive Order 11988, and Protection of Wetlands Executive Order 11990.
6. For transportation off-site, approval from the U.S. Department of Transportation, the Environmental Protection Agency, and other relevant Federal and State authorities.

Reference

1. U.S. Department of the Army, "Chemical stockpile Disposal Program Final Programmatic Environmental Impact Statement," vols. 1,2,3, Office of the Program Manager for Chemical Demilitarization, Aberdeen Proving Ground, MD, 1988.

This led to the impression that the Army had "sneaked" chemical weapons into the area without any regard for the safety of citizens who lived nearby (17). Although the amount of chemical weapons stored at the Kentucky depot is proportionally small (1.6 percent of the total U.S. stockpile), local residents are aware that Kentucky's share includes a higher proportion of the most dangerous types, especially the M55 rockets (69,500 rockets out of a total of 478,000, or 14.5 percent in the total M55 rocket stockpile) (9, 11, 12).

At present, organized opposition to the Army's CW incineration program in Kentucky comes from members of the State legislature; civic leaders; academics; and key political, citizen, and national groups that together comprise a highly organized and potentially very effective opposition (17). In 1988 (when the Army's PEIS was published), the Governor of the State of Kentucky stated that the chemical weapons at the Lexington-Blue Grass

Army Depot should be moved to another site for destruction (18).

Based on conversations with representatives from three Kentucky citizen groups (the Kentucky Environmental Foundation, Concerned Citizens of Madison County, and Common Ground), opposition is based on several issues, and there is no consensus on which concerns are most important. Issues of public concern include the possible health risks associated with effluents from incineration, as well as the possibility that the planned CW destruction facilities will be used to incinerate other types of waste once the weapons disposal program is complete. The latter concern is founded partially on reports that specifically direct the Army to consider using the incinerator facilities, after the completion of CW destruction, for the disposal of hazardous waste generated by DOD; Federal, State, or local governments; and private industry (3, 5, 19). A general concern is that the Army may have not adequately addressed unique aspects of the Kentucky Blue

Grass facility, such as its proximity to major population centers.¹ Another often repeated issue is the perceived risk to citizens in communities surrounding CW stockpiles during munitions transport from storage igloos to the central on-site incinerator facility.

As a result of this last concern, Kentucky citizen groups continue to express a strong preference for the option of removing the chemical weapons from Kentucky to some other site for storage or destruction using a transport container that would prevent leakage in case of an accident. They refer to the 1987 Mitre report concluding that there is no significant difference in risk between on-site incineration and moving the stockpile to a less populated area (1,12). They also cite the Army's successful movement of CWs stored in Germany to Johnston Island in the summer of 1990 (17, 20). Many of the communities that surround the Lexington-Blue Grass Army Depot have indicated a reluctance to have chemical weapons transported through their own communities. Similarly, the Army's counter argument is that the Mitre risk assessment failed to consider the geographic location and the potential for adequate response to accidents occurring on-site versus those occurring during transportation off-site (7).

Projected Program Schedule— Revised Deadlines

The Army's current proposed schedule for its CW destruction program is shown in table 2-3. This schedule has been revised more than once since the 1988 PEIS, and unforeseen events may prompt further revisions. The schedule shown in this table was presented to Congress on April 1, 1992 (21).

Cost Estimates-Cost Overruns

The Army's cost estimates for the CW destruction program have been continually revised upward. In 1985 the Army's life-cycle cost estimate for completion of destruction of the CW stockpile at the eight continental U.S. storage sites and Johnston Island was \$1.7 billion. In 1988 the Army revised the total program cost to \$3.4 billion (19). Recent reports

indicate that the Army is revising its cost estimates for CW destruction upward to \$6.5 billion (3, 17) or as high as \$7.9 billion (21). The largest portion of the cost is for existing and projected operating expenses (while the incineration facilities are operational). Facility construction is a small fraction of the total cost (17).

INTERNATIONAL IMPLICATIONS OF A SUCCESSFUL PROGRAM

The United States and former Soviet Union signed a bilateral agreement in June 1990 to destroy their CW stockpiles, although acceptable verification and destruction technologies were not resolved (3, 22). The agreement timetable specified that destruction should begin by December 1992; that 50 percent stockpile would be destroyed by December 1999, followed by all but 5,000 metric tons destroyed by May 2002. Although the agreement was not ratified by either country, some of its provisions were adopted. Both nations have declared an end to CW production and in May 1991 president Bush forswore U.S. use of chemical weapons and pledged to destroy all U.S. chemical weapons within 10 years of the Geneva global chemical weapons convention (CWC) negotiations (a multilateral effort now in its 24th year) coming into effect. This renunciation was very positively received by the participants of the convention and was widely seen as a significant impetus for the CWC negotiations (3). If ratification of the bilateral agreement continues to be delayed, then the CWC may be concluded and allowed to supersede the U.S./Soviet bilateral agreement on CW destruction (3).

Negotiations over the bilateral agreement were prolonged primarily by the Soviet Union's inability to develop a workable plan for the destruction of its chemical weapons. U.S. officials now believe that the agreement deadlines will have to be extended because of the lack of CW destruction facilities in the independent republics. The agreement allowed for postponement of deadlines should either side encounter delays in the construction of facilities.

¹The Kentucky Lexington-Blue Grass Army Depot, which stores chemical weapons and is the proposed site of the Army's chemical weapons destruction facility, is 1/2 mile from an elementary school, in an area with approximately 55,000 inhabitants. Several schools are within a 5-mile radius of the depot (1, 17). A related problem is the apparently poor credibility of the Army in the eyes of many of the citizens in the affected area. For example, late in 1991 an incident in which a small amount of leaked mustard agent was detected by the Army inside one of the munitions storage igloos at the Lexington-Blue Grass depot was revealed to the general public indirectly via a "leak" to a local school newspaper. Public reaction to this apparently minor incident was one of outrage and expressed the general feeling that the Army was neither sincere in its efforts to protect the public nor credible in keeping the public informed of potential hazards.

Table 2-3-U.S. Chemical Weapons Disposal Program Implementation Schedule

	CY 89	CY 90	CY 91	CY 92	CY 93	CY 94	CY 95	CY 96	CY 97	CY 98	CY 99	CY 00	CY 01	
JACADS	SYST	7/90	OVT		3/93		OPNS	2/96						
							(36)	CLO						
CDTF	6/89	CONST/SYST	10-91					OPNS			12/99			
								(99)			CLO			
TEAD	9/89		CONST		8-93	SYST	2-95		OPNS			4/00		
			(47)			(18)			(63)			CLO		
ANAD	7/89	DES			1/83	REP	6/93	CONST	4/96	SYST	1/97	OPNS	1/00	
					(14)		(34)		(18)		(38)		CLO	
UMDA	6/89	DES			1/83	REP	1/94	CONST	11/96	5/98		OPNS	1/00	
					(12)			(34)				(32)	CLO	
PBA	8/89	DES			1/93	REP	1/94	CONST	9/96	SYST	3/98	OPNS	1/00	
					(12)			(32)		(18)		(33)	CLO	
PUDA	10/89	DES			5/93	REP	5/94		CONST	3/97	SYST	9/89	OPNS	5/00
					(12)				(34)	(18)				CLO
LBAD	10/90	DES			5/83	REP	5/94		CONST	3/97	SYST	6/98	OPNS	4/99
					(12)				(34)	(18)				CLO
NAAP			??			1/93	REP	1/95	CONST	6/97	SYST	6/98	OPNS	4/99
						(12)			(29)	(12)		(11)		CLO
APQ				1/92		1/94	REP	1/95	CONST	6/97	SYST	6/98	OPNS	6/99
						(12)			(29)	(12)		(11)		CLO

JACADS = Johnston Atoll Chemical Agent Disposal Facility
 CDTF = Chemical Demilitarization
 TEAD = Tooele Army Depot
 ANAD = Anniston Army Depot
 UMDA = Umatilla Depot Activity
 PBA = Pine Bluff Arsenal
 LBAD = Lexington-Bluegrass Army Depot
 NAAP = Newport Army Ammunition Plant
 APQ = Aberdeen Proving Ground

DES = Design
 SYST = Systemization
 CONST = Construction
 OPNS = Operations
 CLO = CLOSure
 OVT = Operational Verification Testing
 RFP = Issue and Evaluate Request for Propose
 V. start activity first of month
 T = complete activity end of month

SOURCE: Livingstone, S., Assistant Secretary of the Army (Installations, Logistics and Environment), testimony before the House Committee on Appropriations, Subcommittee on Defense, April 1, 1992, Second Session, 102nd Congress.

According to the June 1990 bilateral agreement, destruction technologies were to be shared. However, it appears that Soviet CW destruction capabilities are currently nonexistent. The entire CW stockpile is located in Russia (23), which may be requesting U.S. assistance in building CW destruction facilities. The political disarray caused by the breakup of the Soviet Union into independent republics has made this more difficult.

The U.S. CW destruction program has also been delayed, as described earlier in this paper. Recently, on the recommendation of the House Committee on Appropriations, the FY 1992 DOD appropriations bill as passed by the House prohibited obligation of \$151.9 million in procurement funds for the CW destruction facilities planned at Anniston, Umatilla, and Pine Bluff until the following events occurred: Operational testing at Johnston Island is certified complete and a report submitted to Congress; the Johnston Island plant design has been verified; and appropriate environmental permits for the three new facilities have been secured. The restriction for obligation of procurement funds for Anniston is tied to the start of the third phase of Operational Verification Testing of JACADS (OVT 3) (24).

In developing their current disposal programs, the United States and Russia are setting the stage for general and worldwide weapons disposal. The control and prevention of the proliferation of chemical weapons is a problem paralleling that of nuclear weapons: They have in common similar problems of the verification of manufacture or destruction, and the potential for illegal use. A United Nations special commission is currently investigating possible methods for the destruction of Iraq's CW stockpile. Iraq has acknowledged having a variety of chemical weapons containing nerve and blister agents that will be destroyed under this program (25). As many as 18 countries in addition to the United States and the Commonwealth of Independent States (C. I. S.) may possess chemical weapons. In testimony before the House Committee on Armed Services in 1991, Rear Admiral Thomas Brooks, Chief of Naval Intelligence, estimated that the following 14 non-NATO or non-Warsaw Pact countries probably have chemical weapons: Burma (Myanmar), China, Egypt, India, Iran, Iraq, Israel, Libya, North Korea, Pakistan, South Korea, Syria, Taiwan, and Vietnam (3). Indonesia, Saudi Arabia, South Africa, and Thailand were also identified as possibly having chemical weapons. As international

proliferation of chemical weapons expands, the need for an appropriate and acceptable CW disposal program becomes increasingly critical.

The C.I.S. is facing problems surprisingly similar to those of the U.S. Army in establishing a CW destruction program. In 1990 the Soviets unveiled their only CW destruction plant near Chapayevsk in the Ural Mountains, 500 miles southeast of Moscow (1, 20). In contrast to the U.S. Army's program, this facility was designed to use chemical neutralization rather than incineration as the primary means for CW destruction. However, local citizens opposed to the facility for ecological and environmental reasons, and possibly as a reaction to the Chernobyl nuclear accident in 1986, were successful in opposing the facility and it was eventually shut down (1).

ALTERNATIVE SCENARIOS FOR THE ARMY'S BASELINE PROJECT

The current Army program for CW destruction specifies destruction by disassembly and incineration on-site at the eight continental U.S. Army bases and at Johnston Island where they are now located. The Army is required by law to prove the successful demonstration of the Johnston Island chemical Agent Disposal System. Results from this prototype design are intended to be used as a basis for design and construction of the eight proposed continental U.S. facilities. This "new-generation" CW incinerator is designed to show that the technology can meet current TSCA and RCRA standards. The Clean Air Act does not apply to the JACADS facility and therefore the Army is not collecting data to demonstrate compliance with this act. Since all eight continental sites will have to host Clean Air Act standards, operation and tests of the JACADS facility will not provide all the data needed.

The first of four planned evaluations by the Mitre Corp., "Evaluation of the GB Rocket Campaign: Johnston Atoll Chemical Agent Disposal System Operational Verification Testing," was released in June 1991 (14). In September 1991, the NRC released a "Letter Report" review of this first evaluation. In the review, the NRC was optimistic about the eventual success of the JACADS demonstration project and recommended that operational testing be continued. It also made several relevant criticisms that suggested certain shortcomings in the JACADS evaluation strategy:

Additional performance measurements, which could be made at JACADS, would support future sites by providing higher levels of confidence in the technology. . . [The current program] does not require measurement. . . of PICS. . . especially dioxins and furans. . . There is a larger issue than the accuracy of. . . measurements. It is important that the total environmental impact of JACADS be characterized. . . . These data would facilitate permitting and public understanding by providing well documented answers to reasonable, and probably inevitable, questions from concerned citizens as well as regulators.

Although the Army has not had time to respond, these and other criticisms of the JACADS project suggest a series of possible scenarios that may result based strictly on the outcome of the demonstration project.

In one scenario, the Army's demonstration program at Johnston Island could be successfully concluded and the construction of facilities at the continental sites could continue as planned. It would probably be useful to provide local groups and involved States with data from JACADS operations to show safety standards can be met. If citizen groups become convinced that the Army's technology will safely destroy the weapons at each site, and the technology functions as proposed, then the program could proceed without opposition.

In another scenario, the Army's JACADS facility could successfully demonstrate that the technology will perform as expected but the organized opposition would remain unconvinced.

In this case, facilities in individual States might be effectively halted by blocking the issuance of required State permits. In a final scenario, the JACADS incineration technology demonstration project might prove unsuccessful and eventually be abandoned. This, in turn, would probably mean an end to construction at any U.S. site.

The second and third scenarios could result in the need for a CW disposal alternative to incineration, depending on whether opposition was primarily to on-site disposal or to the specific destruction technology. In this event the weapons stockpile would probably be stored and maintained at current sites while an alternative technology and CW destruction program is developed.

CHAPTER 2 REFERENCES

1. Ember, L., "Chemical Weapons Disposal: Daunting Challenges Still Ahead," *Chemical and Engineering News*, 68(33):9-19, Aug. 13, 1990.
2. Picardi, A., International Environmental Assessment Group, Alexandria, VA, "Alternative Technologies for the Detoxification of Chemical Weapons: An Information Document," prepared for Greenpeace International, Washington, DC, May 1991.
3. U.S. Congress, Library of Congress, Congressional Research Service, "Chemical Weapons: U.S. Arms Control Negotiations and Destruction," prepared by Steven R. Bowman, Washington, DC, updated Sept. 25, 1991 and Feb. 13, 1992.
4. U.S. Department of the Army, "Chemical Stockpile Disposal Program Final Programmatic Environmental Impact Statement," vols. 1,2,3, Office of the Program Manager for Chemical Demilitarization, Aberdeen Proving Ground, MD, 1988.
5. National Research Council, *Disposal of Chemical Munitions and Agents* (Washington, DC: National Academy Press, 1984).
6. U.S. Department of the Army, "Chemical Agent and Munition Disposal: Summary of the U.S. Army's Experience," Office of the Program Manager for Chemical Demilitarization, Aberdeen Proving Ground, MD, September 1987.
7. Azuma, E., Office of the Assistant Secretary of the Army, The Pentagon, Washington, DC, briefing at the Office of Technology Assessment, Washington, DC, Oct. 18, 1991.
8. U.S. Congress, General Accounting Office, *Stockpile Destruction Delayed at the Army's Prototype Disposal Facility*, GAO/NSIAD-90-222 (Washington, DC: July 1990).
9. Briefing of Office of Technology staff at the Lexington-Blue Grass Army Depot, Lexington, KY, Dec. 10, 1991.
10. McKenna, W., U.S. Army Armament, Munitions and Chemical Command, Defense Ammunition Directorate, Air, Sea and Toxic Chemical Munitions, Rock Island, IL, personal communication, Dec. 2, 1991.
11. U.S. Department of the Army, "Independent Evaluation/Assessment of Rocket, 115mm: Chemical Agent (GB or VX), M55," U.S. Army Material Systems Analysis Activity, Aberdeen Proving Ground, MD, October 1985.
12. Mitre Corp., McLean, VA, "Risk Analysis Supporting the Chemical Stockpile Disposal Program (CSDP)," prepared for the Office of the Program Manager for Chemical Demilitarization, U.S. Army, Aberdeen Proving Ground, MD, December 1987.
13. Flamm, K. J., briefing at the Office of the Program Manager for Chemical Demilitarization, Aberdeen, MD, October 29, 1991.

14. Mitre Corp., McLean, VA, "Evaluation of the GB Rocket Campaign: Johnston Atoll chemical Agent Disposal System Operational Verification Testing," prepared for the Office of the Program Manager for Chemical Demilitarization, U.S. Army, Aberdeen Proving Ground, MD, June 1991.
15. Wojciechowski, P., briefing at the Office of the Program Manager for Chemical Demilitarization, Aberdeen, MD, Oct. 29, 1991.
16. Baronian, C., Deputy Program Manager and Technical Director, briefing at the Office of the Program Manager for Chemical Demilitarization, Aberdeen, MD, Oct. 29, 1991.
17. Stuart, D., U.S. Congress, General Accounting Office, personal communication, Nov. 4, 1991.
18. Wilkinson, W. G., Governor of the Commonwealth of Kentucky, in a letter dated February 3, 1988 to Brigadere General D.A. Nydam, Program Executive Officer, Program Manager for Chemical Demilitarization, Aberdeen Proving Ground, MD.
19. U.S. Congress, General Accounting Office, *Obstacles to the Army's Plan To Destroy Obsolete U.S. Stockpile*, GAO/NSIAD-90-155 (Washington, DC: May 1990).
20. Morrison, D., "No Easy out," *National Journal*, 23(19):1100-1104, May 11, 1991.
21. Livingstone, S., Assistant Secretary of the Army (Installations, Logistics and Environment), testimony before the House Committee on Appropriations, Subcommittee on Defense, Apr. 1, 1992, Second Session, 102d Congress.
22. U.S. Congress, General Accounting Office, *Stockpile Destruction Cost Growth and Schedule Slippages Are Likely To Continue*, GAO/NSLAD-92-18 (Washington, DC: November 1991).
23. "Russia Not Able To Destroy Chemical Arms," *Chemical and Engineering News* 70(3):17, Jan. 20, 1992.
24. Ned Coale, Department of the Army, Office of the Program Manager for Chemical Demilitarization, personal communication, Apr. 22, 1992.
25. U.S. Congress, Library of Congress, Congressional Research Service, "Chemical Weapons Proliferation: Issues for Congress," prepared by Steven R. Bowman, Washington, DC, June 20, 1991.

Current Technology and Alternatives

CURRENT TECHNOLOGY

The Army's CW Disassembly and Incineration Technology

The Army's current chemical weapons (CW) disposal program involves robotic, machine disassembly of the chemical weapon as appropriate for each specific munition. The various waste materials from disassembly are incinerated separately. These include the chemical agent, explosives and propellants, empty munitions and nonexplosive (storage) containers, and shipping and packing materials (dunnage). Preliminary separation produces individual waste streams that are relatively homogeneous, which makes it feasible to optimize conditions for the incineration of each.

To handle the various waste streams produced by disassembly, four different furnace systems are required:

- Incinerator for the liquid chemical agent and process liquid waste;
- Rotary kiln furnace for the destruction of explosives and propellants, with an accompanying heated discharge conveyor to remove leftover materials;
- Metal parts furnace to decontaminate by incineration the empty bulk containers, shells, and bombs; and
- Dunnage incinerator for the combustion of waste packaging.

The resulting gases and other products of incineration are treated with a variety of modern pollution abatement equipment, including a quench tower, venturi scrubber, scrubber tower, demister, and for the dunnage furnace, a baghouse for removal of particulate. Brine produced by the scrubbers is evaporated, and the resulting salts are packed in drums for eventual landfill. The final products that will require disposal such as landfill are scrap metal, drums of salt, and ash (1).

The time required to dispose of the stockpiles at the eight continental U.S. sites after the incinerators begin to work was estimated in the 1988 Programmatic Environmental Impact Statement (PEIS) to be from 11 months (at Lexington-Blue Grass Army

Depot, Kentucky) to 41 months (at Tooele, Utah). This was recently revised in the Army's March 1991 Program Implementation Schedule (Rev. 3) to 11 months (at Newport, Indiana) and 63 months (at Tooele) (see table 2-3).

EXAMPLES OF ALTERNATIVE TECHNIQUES

A number of techniques have been suggested for disposal of chemical weapons. To be applicable to the current CW stockpile, a technology must be able to effectively destroy or decontaminate the chemical agents, the drained and empty munitions and containers, the associated explosives and propellants, and the munition packaging material (dunnage). The dunnage is largely conventional packing material such as wooden pallets and crates. However, the possibility that the dunnage may be contaminated with CW agents requires that it be treated as if it were contaminated.

In 1991 the international environmental organization Greenpeace published a review of nonincineration alternatives for CW destruction, "Alternative Technologies for the Detoxification of Chemical Weapons: An Information Document" (5). This review was very broad in scope and included many reports of the destruction of a CW agent or related compounds. Virtually none of these alternative techniques with the exception of chemical neutralization has been demonstrated for use with actual CW agents on the scale required for the current disposal program. The Greenpeace review avoids specifically endorsing any single technique and concentrates on those methods that would be most applicable to the destruction of liquid CW agents. Many of the technologies proposed would handle only the chemical agent and the other waste materials would need some other treatment or disposal method.

Many of the CW destruction alternative techniques or technologies discussed in the Greenpeace report or proposed by others are not new and were proposed for CW destruction in the early 1980 or before. In response to a 1982 request to industry for proposals on techniques for CW destruction, the Army received suggestions for agent destruction from eight private companies. These included:

conversion to nontoxic useful chemical products; chemical destruction (neutralization); molten metal, plasmas, pyrolysis; molten salt incineration; acid roasting; cement kiln; large kiln; use of a rotary hearth furnace; supercritical fluid (oxidation); and thermal tower destruction (2). Although these and other techniques might be developed into technologies appropriate for CW destruction, none appears at present to be in a position to serve as an immediate alternative to incineration. Moreover, in the absence of more specific information about alternative technologies for CW disposal, it is impossible to predict which technique could be developed into an acceptable CW disposal technology. The Army rejected these alternatives primarily because it believed they would require much more time to develop or prove capable.

The following is a brief review of four techniques selected only because they have been specifically suggested by various interested groups or technology developers as appropriate for CW destruction: chemical neutralization, supercritical water oxidation, steam gasification, and plasma arc pyrolysis. Many other techniques have been suggested that are not reviewed here. There is no technical basis upon which to select (or reject) these or any other specific technology. Application of the last three techniques to dioxin-contaminated soil has recently been reviewed (3). It is quite possible that if a successful alternative technology is developed for CW destruction, it will be none of these. The proponents of these alternatives believe that they offer advantages because air emissions may be more readily controlled and minimized and because of possible improved safety during on-site handling and transportation. More details of these techniques are provided in appendix A.

Chemical Neutralization

The alternative technology for CW destruction having the greatest amount of available information is chemical neutralization. The U.S. Army had extensive experience with this process for the destruction of CW agents. Chemical neutralization via alkaline hydrolysis was successfully used to destroy a substantial proportion of at least some classes of CW agents in the current stockpile. Hydrolysis is the reaction of water with a chemical, such as the CW agent, using an acid or base catalyst, to produce compounds of greatly reduced toxicity. In principle, alkaline hydrolysis could be a means to

chemically neutralize the agents GB, VX, and mustards. Problems encountered by the Army with alkaline hydrolysis of all types of CW agents may be surmountable today in view of new techniques (see appendix A) that were not considered at the time of the Army's research in this area and of the increased pressure to exploit existing nonincineration techniques in CW destruction. Neutralization technology was, however, rejected by the Army as unsuitable for the current CW destruction program. (Appendix A gives a further description of the Army's work with and decision to abandon neutralization.)

Most experience with large-scale chemical neutralization of chemical weapons has been with the agent GB. This agent was successfully neutralized on a large scale by the use of aqueous sodium hydroxide. Approximately 8.4 million pounds of GB (17 percent of the total weight of all agents to be destroyed in the current program), taken from various munitions and storage tanks, were neutralized at Rocky Mountain Arsenal and Tooele, Utah, between 1974 and 1982. From 1979 to 1981, 13,951 M55 rockets containing GB (approximately 3 percent of today's stockpile and 20 percent of the M55 rocket stockpile at the Lexington-Blue Grass Army Depot) were destroyed by this combined chemical neutralization/incineration process (4).

The drained empty munition and ton (bulk storage) containers left over from this process were treated in a furnace where the explosives were incinerated and the metal parts thermally decontaminated. In general, chemical neutralization applied only to the drained chemical agent itself, and disposal of the remaining waste relied on incineration. Another variation in some of the work performed involved decontamination of drained cluster bomblets and ton containers with a caustic wash to neutralize any residual agent. However, the caustic wash treatment was also followed by incineration.

Although the agent VX, which is structurally similar to GB, can also be chemically neutralized, by hydrolysis with aqueous sodium hydroxide, the Army only demonstrated this on a small scale. Mustard agent has also been shown by the Army to be hydrolyzed under alkaline conditions on a small scale, although only very slowly at ambient temperature. The effectiveness of alkaline hydrolysis of mustards at elevated temperature was not reported (4).

Supercritical Water Oxidation

Supercritical water oxidation (SCWO) has been suggested as a plausible alternative for destruction of the agents contained in chemical weapons (2, 5). Supercritical water refers to water that has been heated and pressurized to a transition point between gas and liquid phases, and thus has some of the properties of both. Organic materials in solution with supercritical water can be oxidized by oxygen introduced from air. This technology is currently under development by U.S. companies (General Atomics, Modell Corp., and Modar) and by at least three major universities, for the destruction of a variety of hazardous wastes including dioxin-contaminated soil (3, 6, 7). Although these companies have prototype devices, none has demonstrated its use with an actual CW agent. Current prototypes would be most appropriate for the destruction of only the liquid chemical agent. However, many nontrivial technical details remain to be worked out before SCWO will be suitable for use even with CW agents alone; no actual CW agents have even been tested with SCWO destruction technology (6) (see appendix A for more details). Their design would not be suitable for decontamination of drained munitions and containers, or for destruction of the explosives and propellants loaded into burster tubes, etc., associated with CW munitions. SCWO is being developed commercially as a general technology for the destruction of many different organic hazardous materials, and the destruction of CW agents is conceived by its developers as, at most, a minor application of its use.

SCWO in principle may have certain advantages over incineration for the oxidation of organic waste. It is similar to incineration in that it involves oxidation of organic compounds to carbon dioxide and inorganic acids or salts. However, SCWO operates at much lower temperatures than incineration. Further, it does not require a large airflow. SCWO carries out oxidation at lower temperature, and the reaction medium (water) can be contained until tested to be safe. Potential products of incomplete combustion (PICs) are entrained in solution rather than emitted in stack gases. The apparently superior control of emissions is an attractive feature of SCWO technology. The effluents from SCWO, in contrast to the exhaust stack gases from incineration, may be collected, analyzed, and even recycled to achieve more complete destruction.

Steam Gasification

Steam gasification (or reformation) has been proposed for the destruction of chemical weapons by Greenpeace and by Kentucky citizen groups. Steam gasification would treat organic materials such as chemical agents (as well as propellants and explosives) with high temperature steam to produce simple organic molecules. One vendor is developing and marketing a portable device using high-temperature steam gasification for the destruction of gaseous, liquid, and solid organic-containing wastes (8). The machine is designed to handle bulk objects such as 55-gallon drums filled with waste, and therefore may be suitable for handling certain munitions and bulk CW containers. However, the device has not been tested with actual CW agents or actual CW munitions.

In contrast to conventional incineration, steam gasification does not use an airflow, so the gas produced by the process is minimized. The same vendor is currently working on CW disposal problems for the DOE, such as solvent contaminated soil, that do not involve chemical weapons. It proposes the use of one or more of its mobile devices operating directly in or next to a CW storage igloo. With proper modification, the igloo might serve as a secondary confinement container. The vendor claims that this system could avoid the risks associated with transporting chemical weapons out of the igloo, a major concern to some citizen groups that live around such facilities.

Plasma Arc Pyrolysis

Plasma arc pyrolysis, currently in the development stage, has also been proposed for destruction of chemical weapons by Kentucky citizen groups. In this process, chemical substances are dissociated into their atomic elements in a thermal plasma field created by passing an electric current through a low-pressure airstream. The entire system is transportable on a tractor-trailer bed. The most significant limitation of plasma arc pyrolysis treatment is that only liquids can be treated. Contaminated soil and viscous materials cannot be processed by the system (3). Therefore, plasma arc pyrolysis technology in its current form would not be suitable for the treatment of contaminated, drained munitions or of the containers, explosives, propellants, and dunnage associated with chemical weapons.

Improved Interim Continued Storage— The CW Demilitarization Alternative

In view of the current uncertainty about when any technology will be available for destruction of the CW stockpile, an interim alternative that would involve the transfer of chemical agents from munitions to superior-quality, long-term storage tanks has been proposed (9, 10). It is not clear if the approach of interim storage would conflict with either bilateral or multilateral treaties on CW disposal. The advantage of interim storage would be to secure the CW agents in the existing stockpile, particularly those in the M55 rockets, while developing some alternative destruction technology. Although not analyzed in this report, in principle the separation of chemical agents from explosives and propellants could enhance the safety of storage. This would still require a mechanical weapons disassembly process for removal of the chemical agents, as well as subsequent decontamination and disposal of the drained munitions and corresponding explosives and propellants.

Although it is likely that solving these problems may be no less difficult than disposal of the CW agent itself, an analysis of separating the chemical agents from the M55 rockets has been carried out for the Army (11). That study presented a conceptual engineering design, cost estimate, and risk assessment for draining and storing in bulk containers the chemical agents from the explosive and propellant portions of the M55 rockets. The remaining rocket components were to be chemically decontaminated and stored for latter disposal. The report did not address the issues of the storage and ultimate destruction of the separated rocket components, the chemical decontamination solutions or the CW agents. Moreover, the report indicated that the rocket separation concept was in an extremely early stage of development and should be viewed as preliminary in nature. As with any new unproven technology that might be applicable to CW destruction, pilot-plant testing and verification of the process would be required before it could be implemented (11). A possible interim solution for the leaking M55 rockets would be to place all of the rockets now in storage into the protective steel "overpack" containers that the Army already uses only for leaking rockets (see box I-C).

Alternatives Involving Transportation and Relocation of the CW Stockpile

In the 1988 PEIS, the Army considered and rejected the alternative of partial or complete relocation of the U.S. CW stockpile to either regional or national sites for disassembly and incineration because the overall risk was calculated to be higher. However, CW relocation may in principle be considered with whatever destruction technology is selected. In 1987 the Mitre Corp. prepared a risk assessment for the Army that compared various transportation alternatives (12). Further details of this report are given in Appendix B.

Since the condition of the U.S. CW stockpile has not received rigorous analysis, many conclusions about the relative safety of various transportation options will remain questionable regardless of the specific destruction technology used. The only options considered in the Mitre report were continued storage (the "no-action" alternative) versus on-site destruction, and partial or complete relocation, for destruction via disassembly-incineration. The Mitre risk comparisons considered only relative risks to the general population and excluded risks to workers at the CW destruction facilities.

The risks associated with different options will be borne by different populations. Thus, the risk of continued storage will be borne mostly by the population surrounding the storage site, whereas the risks associated with transport will be borne largely by populations along the transportation corridor and at the final destination (12). The fact that the risks for various alternatives might generate controversy among the different populations involved was not considered in the Mitre risk assessment.

According to the Mitre report, the continued storage option had significantly greater expected fatalities than all other alternatives when considering the combined risks at all eight U.S. sites. Using appropriate safety procedures, on-site incineration was estimated to be significantly less risky than any other alternative considered. Combining the total risk at all eight U.S. sites, the continued storage alternative—even with appropriate safety procedures—had the greatest expected fatalities associated with it, whereas on-site destruction involves the least risk. Regional, national, or partial relocation and disposal alternatives, respectively, have increasingly greater expected fatalities than on-site destruction (12). The

on-site disposal alternative also had the lowest probability of causing one or more fatalities, and partial relocation the highest. For the on-site disposal alternative, transportation activities accounted for 44 percent of the expected fatalities and plant operations for 48 percent. In this situation, the M55 rockets in the CW stockpile accounted for 50 percent and bulk containers 42 percent of the expected fatalities.

The general conclusions reached about the relative risks of transportation alternatives for the combined eight sites often differed significantly from the conclusions reached by site-specific analyses. For example, the risk from continued storage with appropriate safety procedures was much lower at the Lexington-Blue Grass Army Depot than at the seven other U.S. sites. Although the risk of continued storage was clearly greater than that of on-site disposal at the Aberdeen (Maryland), Newport (Indiana), Pueblo (Colorado), Tooele (Utah), and Umatilla (Oregon) sites, this was not the case with Lexington-Blue Grass Army Depot (Kentucky) and Pine Bluff (Arkansas) facilities.

Transportation of chemical weapons from their current sites to regional or national locations for destruction may be challenged by the States through which they would have to be moved. The Army 1988 PEIS stated that rail is the preferred mode for the transportation alternative (13). It described a regional relocation plan using rail shipment to relocate all continental U.S. chemical weapons to the Tooele (Utah) and Anniston (Alabama) sites. This plan requires CW transport from 730 to 1,800 miles, through 5 to 11 States. A national relocation plan described by the Army in its 1988 PEIS calls for rail shipment of all chemical weapons within the continental United States to the Tooele site. This plan requires CW transport from 730 to 2,670 miles, through as many as 20 States. A partial relocation plan was also considered that calls for moving the chemical stockpiles from the Lexington-Blue Grass Army Depot and Aberdeen sites to Tooele for destruction. This plan specified approximately 2,100 to 2,700 air flights over 1,500 to 2,060 miles.

CHAPTER 3 REFERENCES

- 1 Whelen, R. P., Engineering and Technology Division, briefing at the Office of the Program Manager for Chemical Demilitarization, Aberdeen, MD, Oct. 29, 1991.
2. Baronian, C., Deputy Program Manager and Technical Director, briefing at the Office of the Program Manager for Chemical Demilitarization, Aberdeen, MD, Oct. 29, 1991.
3. U.S. Congress, Office of Technology Assessment, *Dioxin Treatment Technologies- Background Paper, OTA-BP-O-93* (Washington, DC: U.S. Government Printing Office, November 1991).
4. U.S. Department of the Army, "Chemical Agent and Munition Disposal; Summary of the U.S. Army's Experience," Office of the Program Manager for Chemical Demilitarization, Aberdeen Proving Ground, MD, September 1987.
5. Picardi, A., International Environmental Assessment Group, Alexandria, VA, "Alternative Technologies for the Detoxification of Chemical Weapons: An Information Document," prepared for Greenpeace International, Washington, DC, May 1991.
6. Davison, W., Director, Advanced Processing Systems, General Atomics, San Diego, CA, personal communication, Nov. 19, 1991.
7. Modell, M., Modell Development Corp., Framingham, MA, personal communication, Nov. 14, 1991.
8. Galloway, T., Synthetic Technologies Inc., Richmond, CA, and Sprung, J. L., Sandia National Laboratories, Albuquerque, NM, personal communication, Dec. 20, 1991.
9. Hawkins, S., Greenpeace Pacific Campaign, Washington, DC, personal communication, Oct. 22, 1991.
10. Hille, P. J., Common Ground, Berea, KY, letter review of the OTA draft on alternatives for chemical weapons disposal, Apr. 15, 1992.
11. Arthur D. Little, Inc., Cambridge, MA, "M55 Rocket Separation Study," prepared for the Office of the Program Manager for Chemical Demilitarization, U.S. Army, Aberdeen Proving Ground, MD, November 1985.
12. Mitre Corp., McLean, VA, "Risk Analysis Supporting the chemical Stockpile Disposal Program (CSDP)," prepared for the Office of the Program Manager for Chemical Demilitarization, U.S. Army, Aberdeen Proving Ground, MD, December 1987.
13. U.S. Department of the Army, "Chemical Stockpile Disposal Program Final Programmatic Environmental Impact Statement, ' vols. 1,2,3, Office of the Program Manager for Chemical Demilitarization, Aberdeen Proving Ground, MD, 1988.

Selected Chemical Weapon Destruction Techniques

CHEMICAL NEUTRALIZATION: THE ARMY'S EXPERIENCE

In a 1969 report, the National Research Council (NRC) recommended chemical neutralization for the destruction of the chemical weapons (CW) agent GB and incineration for mustard agents H and HD. After research and development work on chemical neutralization at the Chemical Agent Munitions Disposal System (CAMDS) (Tooele, Utah) and Rocky Mountain Arsenal (Denver, Colorado) in the 1970s, the Army concluded that incineration was the best method for the destruction of all chemical weapons. The NRC Committee on Chemical Weapons Disposal has recently been asked by the Army to reevaluate incineration and alternatives for CW disposal.

Chemical Neutralization of Nerve Agents

Most of the Army's experience with large-scale chemical neutralization of chemical weapons was with the organophosphorus ester agent GB. This agent was successfully neutralized using aqueous sodium hydroxide on a scale compatible with destruction of the current U.S. CW stockpile. Approximately 8.4 million pounds of GB-taken from underground storage tanks, GB ton containers, M139 bomblets (Honest John Warhead), M34 cluster bombs, M55 rockets, and 155/105-mm projectiles, were neutralized at Rocky Mountain Arsenal from 1974 to 1976 and at CAMDS between 1979 and 1982. By weight, this represents 17 percent of the 25,000 tons of agent to be destroyed in the current program.

GB is stable at neutral pH but is hydrolyzed rapidly at alkaline pH. The half-life of GB at 300 C in aqueous solution is 146 hours at pH 7 (neutral conditions) but decreases to 0.4 hour at pH 9 (alkaline conditions) (1). Presumably at higher pH and temperature, the hydrolysis rate would be even more rapid. The suggestion has been made that the addition of a catalyst could speed up this hydrolysis reaction even more (2).

As part of the Army's program, after GB neutralization was determined to be complete, the resulting brine was evaporated by spray drying and the salts were packed into drums for disposal. There were some problems with the spray-drying process, including the possibility that GB might re-form under certain conditions. This re-formation could be successfully avoided by adjusting the pH and brine flow rate, and by reducing the operating temperature (1).

Difficulties were also encountered in confirming that the brine was agent-free. Particularly at the CAMDS

facility, minute quantities of agent were detected in the brine. At Rocky Mountain Arsenal the neutralization brine was considered agent-free if a 5 percent excess sodium hydroxide level was achieved. At CAMDS a more strict criterion was used of less than 20 parts per billion (ppb) agent (the Army's soldier drinking water standard). Difficulties in certifying this level of destruction at CAMDS may have come from occlusion of GB in rust or other particulate, formation of GB during analysis, or false positives resulting from some unidentified interference in the complex neutralization mixture (1). Agent emissions at the facility during brine spraying at Rocky Mountain Arsenal often exceeded the action level (0.0003 milligram per cubic meter (mg/m^3)) and occasionally the shutdown level (0.003 mg/m^3). These levels were promulgated by the Department of Health and Human Services (DHHS) and the Army's Surgeon General. However, perimeter monitors showed that the emission standard for the general population was not exceeded (1).

After being drained of GB, the empty munition bodies were moved to a deactivation furnace where explosives and propellants were incinerated and metal parts thermally decontaminated, i.e., incinerated. Empty ton containers were similarly incinerated in separate furnaces. Thus, "chemical neutralization" actually applied only to the drained agent and treatment of the remaining waste depended on incineration. However, disposal of the M34 cluster bomblets and ton containers used a caustic (aqueous sodium hydroxide) wash to treat the drained container by neutralizing any residual agent. For some reason—possibly a lack of confidence in the efficacy of this process—the caustic wash treatment was also followed by thermal decontamination (incineration).

From 1979 to 1981, 13,951 M55 rockets containing GB (2.9 percent of the current M55 rocket stockpile) were destroyed by this combined chemical neutralization/incineration process (1). The Army also reported problems with re-formation of GB during the brine drying process, although it is not clear why the corrective actions described above were not applied to solve the problem in this instance. The reaction was also reported to take longer than expected. Adding excess sodium hydroxide to accelerate the reaction created a larger amount of salt for disposal. Given the intrinsically rapid hydrolysis rate of GB under alkaline conditions (corresponding to a short half life), the apparent slow reaction encountered in this situation may have been due to problems associated with the large scale of the demonstration such as complete and thorough mixing of the organic material with the aqueous sodium hydroxide.

Although the agent VX, which is structurally similar to GB, can also be chemically neutralized, this was never demonstrated by the Army on a large scale. Acid chlorinolysis (chlorination in an aqueous acidic medium followed by caustic neutralization) rather than alkaline hydrolysis was suggested by the Army as the best method for chemical destruction of VX (1). However, VX was shown to be neutralized on a small scale by hydrolysis with sodium hydroxide. The problems encountered with the neutralization of GB led the Army to abandon plans to test the large-scale neutralization of VX. The Army indicated that a poor water volubility, mixing problems, and the presence of a "bis" impurity (with unspecified susceptibility to alkaline hydrolysis) made alkaline hydrolysis of VX difficult (1). As with GB, neutralization was apparently intended only for the liquid chemical agent. Incineration was to be used for destruction of the explosives and propellant components, and for thermal decontamination of munition cavities and metal parts. In addition, lack of a reliable low-level monitoring capability for VX in the neutralization brine at the time of the Army's research program led it to conclude that DHHS would never approve chemical hydrolysis (1).

Chemical Neutralization of Mustard Agents

Mustard agent has also been shown in the Army's research to be hydrolyzed under alkaline conditions on a small scale, although only slowly at ambient temperature. The corresponding reaction rates with alkaline hydrolysis at elevated temperature were not reported. The products of mustard hydrolysis with sodium hydroxide were not identified and their toxicities were not assessed. Alkaline hydrolysis of mustard agents on a pilot-plant scale was reported, using the base monomethanolamine instead of sodium hydroxide, to produce a homogeneous nontoxic organic waste. Calcium hypochlorite slurry or aqueous bleach (sodium hypochlorite) was used to oxidize rather than hydrolyze mustard agents, but there was "uncertainty about the completeness of the reaction" (1).

Summary of the Army's Neutralization Process Experience

In the Army's summary of its experience with chemical neutralization, the following reasons were given for abandoning the process in favor of incineration (1):

1. ***The perceived complexity of neutralization compared to incineration.*** Caustic reactants used for chemical neutralization had to be handled safely in bulk quantities. However, many industrial large-scale processes routinely use such caustic agents, e.g., the manufacture of soap. The major safety issue in handling chemical weapons will always be the agents themselves.
2. ***The sensitivity of neutralization to a number of variables that could slow the reaction and possibly***

lead to re-formation of the agent. In some situations, the rate of neutralization in large-scale tests of chemical agents was much slower than had been predicted. Very large amounts of impurities in certain grades of mustard agent also made neutralization difficult to monitor adequately. However, it is not clear that the problems encountered with "industrial scale-up" of chemical neutralization are insurmountable, and the scale of a chemical neutralization program is similar to or smaller than that of industrial large-scale processes.

3. ***The quantity and nature of the waste produced by neutralization are more problematic than those produced by incineration.*** Calculations by the Army indicated that 1 pound of GB will produce 1.5 pounds of salt, compared to a salt yield of 1.4 pounds from incineration. In practice, the excess caustic added to speed up the reaction led to 2.6 pounds at Rocky Mountain and 3 to 6 pounds at CAMDS of salt per pound of agent hydrolyzed. The Army speculated that the sometimes heterogeneous form of some agents (partially gelled, mixed with solid particles such as rust) may have contributed to the variation in results obtained with chemical neutralization. These types of technical problems encountered in the transformation of industrial processes from bench-scale demonstrations may not be insurmountable given sufficient motivation to reach a solution. Also, it has been argued that producing larger amounts of salts from neutralization may be relatively more acceptable than some of the perceived problems of incineration, such as the formation of dioxins.
4. ***The capital and operating costs of chemical neutralization were estimated to be higher than those of incineration (1).*** This cost comparison might have to be considerably revised now in light of the unanticipated cost increases in the Army's incineration program, which are due in part to technical problems encountered by the Army after 1987 (3).
5. ***The analytical problems encountered in certifying that the waste materials of chemical neutralization were agent-free.*** This must be compared to the analytical problems faced in demonstrating that incineration products of incomplete combustion (PICs) are dioxin or agent-free, etc.

After reviewing the Army's experience with chemical neutralization and incineration of chemical weapons, the NRC in 1984 supported the Army's decision to abandon chemical neutralization in favor of incineration. In light of the current political opposition to incineration, and after considerably more experience with this technology, it is not clear that the same endorsement would be made today. In principle, with appropriate conditions, alkaline hydrolysis could be a means to chemically neutralize the CW agents GB, VX, and mustards. Problems encountered

with alkaline hydrolysis of all types of CW agents might today appear to be surmountable in view of new techniques as well as increased pressure to exploit existing techniques for use with CW destruction. The NRC's Committee on Review and Evaluation of the Army Chemical Stockpile Disposal Program and Committee on Alternative Chemical Demilitarization Technologies, were recently requested by the Army to reevaluate incineration and alternatives for CW disposal.

SUPERCRITICAL WATER OXIDATION

Supercritical water refers to water that has been heated and pressurized to a transition point between gas and liquid phases, and thus has some of the properties of both. In the supercritical phase the solvent properties of water change, and organic materials becomes soluble, whereas inorganic salts become insoluble and tend to precipitate (4). Organic materials in solution with supercritical water can be oxidized by oxygen introduced from air. This is a broad-spectrum oxidation procedure for organic compounds, and at elevated temperature (4000 C), even refractory compounds such as coal are oxidized (5). Supercritical water oxidation (SCWO) is similar to incineration in that it involves oxidation of organic compounds to carbon dioxide and inorganic acids or salts. However, SCWO operates at much lower temperatures than incineration. SCWO is under commercial development as a general technology for the destruction of many different organic hazardous materials, and the destruction of CW agents would at most constitute only a small portion of its use.

SCWO may have certain advantages over incineration for the oxidation of organic waste. Compared to incineration, SCWO has no requirement for a large airflow. SCWO carries out oxidation at lower temperature, and the reaction medium (water) can be contained until it is tested to be safe. A major selling point of this technology is that potential PICs are entrained in solution rather than emitted in stack gases. The apparently superior control of emissions is an attractive feature of SCWO technology. The effluents from SCWO, in contrast to exhaust stack gases from incineration, may be collected, analyzed, and even recycled to achieve more complete destruction.

In discussions with Modell Corp. and General Atomics, two companies that are involved in the development of SCWO for CW agent destruction, it was apparent that currently there are both advantages and limitations with this technology. Modell has completed the initial phase of a research program on the use of SCWO for the treatment of CW agents (5). It has successfully demonstrated for the Defense Advanced Research Project Agency (DARPA) the destruction of "simulants" (analogs) of GB, VX, and HB on a bench scale. Modell achieved "destruction and

removal efficiencies" (DREs) of 99.99999 percent and has proposed, but not begun, a demonstration of the technology for DARPA with actual agents. Although Modell has not yet worked with actual CW agents, it has demonstrated the oxidation of some explosive materials such as the effluent from TNT manufacture ('red water').

The formation and environmental release of dioxin, a concern in the incineration of organic materials, may not be significant for SCWO. Modell has demonstrated that the dioxin congener (TCDD) was oxidized to below detectable levels when introduced at 500 parts per million (ppm). The Modell technology has also been demonstrated to work for the destruction of dioxin in pulp mill waste streams. Wood, when suitably pulverized and converted to a flowable form, can also be treated.

Gaseous effluents from SCWO are carbon dioxide and oxygen with traces of carbon monoxide (10 to 15 ppm with optimized operation). In Modell's process, these effluent gases are expanded and cooled; the carbon dioxide is solidified and removed, and the oxygen is recycled through the system. This process might be considered a "closed" system in comparison with incineration. Oxidation of organic materials containing hetero atoms such as fluorine, chlorine, sulfur, or phosphorus produces the corresponding hydrofluoric, hydrochloric, sulfuric, and phosphoric mineral acids in solution. These can be neutralized, precipitated from the SCWO reactor water solution, and removed from the SCWO reaction vessel.

Although Modell believes that its SCWO technology could be developed for the Army's CW destruction program, it has been unable to interest the Army in this work. From Modell's perspective, the Army's commitment to incineration technology has led it to dismiss viable alternatives such as SCWO. On the other hand, the U.S. Department of Energy (DOE) has apparently expressed an interest in using the technology to treat radioactive mixed waste. In general, Modell considers that the greatest commercial opportunities and market for this technology are not in CW destruction but in other areas of organic waste disposal. The Modell Corp. is currently operating a bench-scale SCWO facility with a capacity of 30 gallons per day and hopes soon to construct an SCWO facility in Germany with a capacity of 5 to 10 tons a day. Modell estimates a cost of \$200 per ton for sludge disposal.

General Atomics' (GA) engineers who are involved with SCWO development are considerably more cautious about the future uses of this technology for hazardous waste and CW agent disposal (6). Although a wide range of organic compounds have been shown by GA to be oxidized by SCWO technology on a bench scale, it has never been demonstrated with actual CW agents. GA is currently under contract to DARPA and the Office of

Naval Research to perform the necessary research and build a prototype SCWO system that would be capable of processing relatively small amounts of chemical agents, propellants, and other U.S. Department of Defense wastes. SCWO as it is presently conceived is not designed to handle solid CW agent disposal waste forms such as drained munitions or dunnage. The research program, which will be conducted with support from the University of Texas, the IIT Research Institute (Chicago, Illinois), and EcoWaste Technologies (Austin, Texas), will initially focus on two areas of importance—corrosion and solids handling. Corrosion with SCWO is a significant issue especially because of the mineral acids formed from the oxidation of compounds containing fluorine, chlorine, sulfur, and phosphorus hetero atoms. The handling of solids, such as the salts formed and precipitated during SCWO, will require careful attention because such inorganic salts can become sticky under SCWO conditions and could foul the walls of the reactor.

The DARPA contract calls for a 15-month research phase to address these and other issues and to develop data, initially on simulants and then on actual CW agents. Concurrently, a 3+-year pilot-plant development effort is planned to lead to the construction and testing of a prototype SCWO unit with a capacity of 1,000 to 1,500 gallons per day. Full *demonstration* of the practical application of this technology to CW agent destruction is therefore estimated by GA to be more than 3 years away.

In discussing the likely success of this application of SCWO, GA tended to be cautious and to emphasize the need for the data that will be developed during the research phase of this work.

GA considers the recent bilateral, as well as current and future multilateral, agreements on CW destruction and nonproliferation to be an ideal opportunity for SCWO technology. For example, the United Nations has announced its intention to destroy the Iraqi CW stockpile, which is considerably smaller than that of the United States. Use of mobile SCWO-based machines for destruction of this type of small stockpile could be an ideal application. Unfortunately, the technology may not be developed in time to be applicable to this particular situation.

STEAM GASIFICATION TECHNOLOGY

A process known as steam gasification (re-forming) treats organic materials with steam at 1,000 to 1,300 °C under reducing conditions to produce carbon monoxide, carbon dioxide, and hydrogen (7). The steam/organic materials stream is recirculated through the high temperature reactor to control destruction efficiency. The carbon monoxide and hydrogen can be reacted over a suitable catalyst to form either methanol or carbon dioxide and

water. Since steam gasification is a reducing process rather than an oxidation process such as incineration PICS will not be formed. This reaction is a temperature-controlled equilibrium process so, in principle, any level of destruction may be achieved by selecting an appropriate temperature.

The current developer is interested in testing its steam gasification system for CW destruction. It has demonstrated the device with CW simulants but not with actual CW agents. The machine is designed to handle bulk objects, including 55-gallon drums filled with waste, and may therefore be suitable for handling properly prepared munitions and CW containers. Drummed wastes are gasified in the drums, one drum at a time, by placing each drum in a chamber operated at 300 to 700 °C. In its current form, halogens are removed from organic materials by pretreatment with alkali, and the remaining dehalogenated organic material is destroyed by steam gasification. Sulfur- and phosphorus-containing materials are converted to salts of their reduced forms hydrogen sulfide and phosphine. In contrast to conventional incineration, steam gasification does not use an airflow so the gas flow output to the environment is minimized.

The developer is offering a “premarket” machine for customer evaluation. The machine is approximately 5 by 6 by 7 feet and costs about \$700,000 when supplied with a drum feeder and flash vaporizer. The company is already working on chemical waste disposal problems for DOE, such as destruction of chlorinated solvents and organic wastes from weapons dismantlement, that do not involve chemical weapons. It has proposed a system that would use one or more mobile steam gasification devices directly in a CW storage igloo or on a truck positioned next to the igloo. In this concept, a modified version of the Army's current M55 rocket shearing system could be coupled to the drum feeder. Passage of hot steam around and through the sheared, drained munition would decontaminate the empty shell. This configuration would have the advantage of avoiding the risk associated with transporting CWs from the igloo to a larger stationary destruction device.

The developer is currently negotiating a contract to destroy napalm bombs located at Camp Pendleton, California, by use of steam gasification. These napalm bombs consist of a 15-foot-long aluminum container filled with napalm and an explosive. The company plans to modify its device to contain an entire bomb during the steam gasification destruction process.

PLASMA ARC TECHNOLOGY

A newly developed Plasma Arc Technology System can process nearly 10 pounds per minute of solid waste or 55 gallons per hour of liquid waste (4). The developer is currently testing plasma arc pyrolysis (PAP) technology,

although it has not specifically tested the system with CW agents. After waste has been atomized in the plasma pyrolysis chamber the resulting elements are cooled in a second portion of the chamber and recombine to form hydrogen, carbon monoxide, and hydrochloric acid. Such plasmas can reach temperatures of 5,000 to 15,000 C. The resulting gases are passed through a wet caustic scrubber for removal of particulate and hydrochloric acid. The remaining gases are combusted with air. The entire system fits on a 45-foot-long transportable tractor-trailer bed.

The most significant limitation of PAP treatment is that only liquids can be treated. Contaminated soil and viscous materials cannot be processed by the system (4). Thus PAP technology in its current form would not be suitable for the treatment of contaminated drained munitions, containers, explosives, or propellants, and the dunnage associated with chemical weapons.

Appendix A References

1. U.S. Department of the Army, "Chemical Agent and Munition Disposal; Summary of the U.S. Army's Experience," Office of the Program Manager for Chemical Demilitarization, Aberdeen Proving Ground, MD, September 1987.
2. Picardi, A., International Environmental Assessment Group, Alexandria, VA, "Alternative Technologies for the Detoxification of Chemical Weapons: An Information Document," prepared for Greenpeace International, Washington, DC, May 1991.
3. U.S. Congress, General Accounting Office, *Stockpile Destruction Delayed at the Army's Prototype Disposal Facility*, GAO/NSIAD-90-222 (Washington, DC: July 1990).
4. U.S. Congress, Office of Technology Assessment, *Dioxin Treatment Technologies-Background Paper, OTA-BP-O-93* (Washington, DC: U.S. Government Printing Office, November 1991).
5. Modell, M., Modell Development Corp., Framingham, MA, personal communication, Nov. 14, 1991.
6. Davison, W., Director, Advanced Processing Systems, General Atomics, San Diego, CA, personal communication, Nov. 19, 1991.
7. Galloway, T., Synthetic Technologies Inc., Richmond, CA, and Sprung, J. L., Sandia National Laboratories, Albuquerque, NM, personal communication, Dec. 20, 1991.

Appendix B

U.S. Army Risk Assessment for Off-Site Transportation of Chemical Weapons

In 1987 a risk assessment on transportation alternatives was conducted by the Mitre Corp. to support the Army's 1988 Programmatic Environmental Impact Statement (PEIS) (1, 2). It was intended to give a consistent and quantitative comparison of the risks of accidental chemical agent exposure to the public during on-site disposal versus various regional or national transportation and disposal alternatives. The analysis assumed that disassembly and incineration would be used with any of the transportation alternatives considered, so that the alternatives consisted only of variations on the logistics of chemical weapons (CW) transportation and the location of disposal facilities. However, many of the conclusions about transportation alternatives, and details about specific storage sites, were independent of the method of CW destruction. The analysis is unique in that it systematically examined and compared risks associated with certain CW transportation options, some of which are still being seriously discussed. Therefore a review of this document is relevant to a consideration of new alternatives.

In the Mitre analysis, risk was specifically defined as risk to the public (individuals outside the boundaries of the military installation) at the proposed disposal sites or along potential transportation corridors. Risks to persons involved in operating and maintaining the facilities were not considered. Only accidents that could result in agent release at potentially lethal concentrations were considered. Risks from chronic effects of long-term, low-level exposure to CW agents, or to materials released during CW incineration, were not included. This present review focuses on the assumptions and conclusions of Mitre's risk assessment and not with the risk assessment methodology.

Five alternatives were evaluated in the Mitre report and in the 1988 PEIS:

1. **On-site disposal.** Chemical weapons would be destroyed at their current locations. Risk was assumed to come from handling, on-site transport, and plant operations.
2. **Regional disposal.** Chemical weapons stored in the eastern United States would be shipped by rail to Anniston Army Depot (Alabama), while those in the western United States would be shipped to Tooele Army Depot (Utah). Risk was assumed to come from the same activities as on-site disposal, with additional risks from handling and off-site transport.
3. **National disposal.** All chemical weapons in the continental United States would be shipped by rail to Tooele Army Depot. Risk was assumed to come from the same activities as on-site disposal, with additional risks from handling and off-site transport.
4. **Partial relocation.** On-site CW disposal would be used at most sites, but the stockpile from Aberdeen Proving Ground (Maryland) and Lexington-Blue Grass Army Depot (Kentucky) would be relocated by air transport to Tooele.
5. **'No-action' alternative.** Chemical weapons would be stored at their current locations for at least 25 years. Risk was assumed to come from relatively rare catastrophic events such as tornadoes or airplane crashes. Although the probability of such accidents is low, the consequences would be great, and the risk extends over a relatively longer time. Risk would also come from normal monitoring and handling operations of the CW stockpile, including the processing of leaking munitions.

Risk was measured exclusively in terms of acute effects as the following:

- Maximum individual risk;
- Maximum lethal plume distance, or minimum distance of an individual from a given site or transportation corridor with no risk of lethal exposure;
- Maximum total time at risk for an individual;
- Probability of one or more fatalities;
- Maximum number of fatalities;
- Expected fatalities;
- Total person-years at risk and
- Expected plume area (used in the study as a surrogate for overall ecological impact).

Comparative risk assessments based on the above criteria were done both on the entire CW disposal program, along with site-specific assessments for the eight individual sites.

Events identified by the risk assessment process that might potentially lead to accidents involving release of and exposure to CW agents could often be mitigated or reduced through design and procedural changes. Risks were analyzed for the unmitigated case and again after appropriate mitigation. Mitigation strategies included: using foam or other materials for rapid spill cleanup, battery-powered lifting devices, blunt bumpers on lift truck tines, improved mobile fire control systems, seismic actuated gas cutoff valves in the munition demilitarization

buildings, metal shields at the explosive containment entry and seismically actuated warehouse circuit breakers, changing the munition unpacking area to prevent mines and rockets from being inadvertently conveyed to the dunnage furnace, freezing mustard ton containers for transportation, and restricting airspace at all sites and eliminating military helicopter flights. The following discussion of the Mitre report emphasizes the conclusions about risk assessments with all appropriate mitigation steps in effect.

Uncertainty in these risk assessments was assumed to come from uncertainty in the estimated probability that an accident would take place, not uncertainty about the consequence of an accident or about estimates of population density, atmospheric conditions, and dose response.

PROGRAMMATIC RISK COMPARISONS (RISK COMBINING ALL SITES)

With mitigation, on-site disposal had the lowest probability of causing one or more fatalities, whereas regional relocation, continued storage, national relocation, and partial relocation with disposal alternatives had 5, 7, 10, and 11 times greater probability of one or more fatalities, respectively. Regional disposal, partial relocation, and national disposal alternatives had, respectively, 10-, 26-, and 30-fold greater expected fatalities than on-site disposal. Even with mitigation, the continued storage alternative had the greatest number of expected fatalities and on-site destruction the least. This resulted largely because the estimated risk from continued storage occurred over a relatively long period (25 years) and came from rare catastrophic events that would have relatively large consequences. With mitigation, on-site disposal had the lowest probability of causing one or more fatalities and partial relocation had the highest. Mitigation did not change the number of maximum possible fatalities. As in the unmitigated case, continued storage had significantly greater expected fatalities than all other alternatives. With mitigation, on-site disposal was significantly less risky than any other alternative considered.

For the continued storage with mitigation programmatic alternative, 99 percent of the expected fatalities were associated with CW storage, and the risk associated with handling and stockpile movement for maintenance and surveillance accounted for the remaining 1 percent. Accidents with bulk containers accounted for 99 percent of the expected fatalities. For the programmatic on-site disposal alternative with mitigation, on-site transportation activities accounted for 44 percent of expected fatalities, and plant operations for 48 percent. The M55 rockets in the CW stockpile accounted for 50 percent and bulk containers 42 percent of expected fatalities.

For the partial relocation alternative without mitigation (which calls for air transport of the CW stockpile from the Aberdeen (Maryland) and Lexington-Blue Grass (Kentucky) facilities to Tooele (Utah) using C141 airplanes), accidents involving rockets contributed 77 percent and in-flight air accidents along the transportation corridor accounted for 46 percent of the total risk. Accidents with the highest consequence were considered to occur during aircraft takeoff involving rockets and projectiles containing GB. Mitigation reduced the probability of one or more fatalities approximately threefold, although expected fatalities were not significantly decreased. Mitigation had the largest effect on reducing risk from plant operations.

SITE-SPECIFIC RISK COMPARISONS

The conclusions reached about programmatic risks for the combined eight sites described above were often different from the conclusions reached by site-specific risk analysis. For example, the risk from continued storage with mitigation was much lower at Lexington-Blue Grass Army Depot than at the seven other U.S. sites. Although the risk associated with continued storage with mitigation clearly was greater than on-site disposal with mitigation at the sites in Aberdeen, Maryland; Newport, Indiana; Pueblo, Colorado; Tooele, Utah; and Umatilla, Oregon, this was not the case with Lexington-Blue Grass and Pine Bluff (Arkansas) facilities.

Major differences were reported in the distribution of risk among populations at the eight continental U.S. sites, in terms of expected fatalities. For the continued storage option with mitigation, the total program risk is mostly from potential accidents involving the CW stockpiles at the Newport Army, Aberdeen Proving Ground, and Umatilla depots. The risk of continued storage with mitigation at the other five sites contributes little to the overall programmatic risk. For on-site disposal with mitigation, 75 percent of the total program risk is borne approximately equally by the Army depots in Pueblo, Colorado, and Newport, Indiana.

For the regional disposal alternative with mitigation, 75 percent of the total program risk is borne by populations along transportation corridors. For the national disposal site alternative with mitigation, 98 percent of the total risk is borne by the population along the transportation corridor. An intuitive understanding of these relative risks may explain why transportation alternatives are more popular with people living near existing stockpile sites.

The total program risk from on-site versus regional disposal was not statistically distinguishable (3). Other factors entered into the Army's decision to select on-site, rather than regional, disposal. The Army argued that the results showing a lack of significant difference in risk

associated with these two programmatic alternatives did not consider the location and mitigation of possible accidents. A qualitative consideration of this risk factor led to the conclusion that any option that involves transportation of chemical weapons off-site is more risky (3).

Appendix B References

1. U.S. Department of the Army, "Chemical Stockpile Disposal Program Final Programmatic Environmental Impact Statement," vols. 1,2,3, Office of the Program Manager for Chemical Demilitarization, Aberdeen Proving Ground, MD, 1988.
2. Mitre Corp., McLean, VA, "Risk Analysis Supporting the Chemical Stockpile Disposal program (CSDP)," prepared for the Office of the Program Manager for Chemical Demilitarization, U.S. Army, Aberdeen Proving Ground, MD, December 1987.
3. Azuma, E., Office of the Assistant Secretary of the Army, The Pentagon, Washington, DC, briefing at the Office of Technology Assessment, Washington, DC, Oct. 18, 1991.

Summary of the Chemical Weapons Workshop

To investigate the feasibility of developing alternative technologies and approaches to chemical weapons (CW) destruction, OTA conducted a 1-day workshop on February 24, 1992. The workshop explored approaches to implementing such a development program if that policy was adopted. The participants were selected from private and public institutions with background and experience in research, development, and demonstration of innovative technologies in the fields of both waste treatment and chemical processing. The agenda was set to first give some history of the current program, to discuss the key obstacles to implementing the technology now under test, and then to discuss ideas for the creation of an alternative, and possibly concurrent, plan.

It was noted that public acceptance problems are seriously affecting the U.S. Government's ability to efficiently and effectively establish incineration facilities at the eight sites and successfully destroy the stockpile of obsolete weapons as directed by treaties and domestic laws. Until these problems are overcome, it is likely that delays will continue and added costs will mount. Some believe that the public acceptance problem, in particular, will prevent incineration facilities from being built and operated in the foreseeable future at some, if not most, of the depot locations.

OTA staff had concluded and the workshop participants agreed, that none of the alternatives to the current Army program, that have been proposed by various individuals or groups, could be expected to be available soon for destruction of the weapons stockpile. Rather, each is in some early stage of development where it must undergo substantial integration with a larger system and testing or field demonstrations before it could be considered acceptable. Further, the process for supporting the development and testing of alternative technologies and systems is limited. While some firms and individuals have proposed alternative technologies that are promising, none have been tested with actual chemical agent and most only address a part of the total weapons destruction system (usually the treatment of the agent itself) and thus must be considered as only part of the total solution.

Because any alternative technology would need to be further developed and tested, the workshop participants discussed how a development program should be structured, how certain promising technologies might be selected for further development, what criteria would be selected for judging the acceptability of new technologies, what other factors need to be considered, and what time and resources would be required. The following is a summary of the points made during these discussions.

An important conclusion of the workshop was that, even though a technology (namely, incineration) may be viewed by the government as the "technically best" or "most available" (or even, as in this case, the "only available"), it may nonetheless be necessary to develop alternative technologies for possible use at some of the sites because some of the communities will not accept the chosen solution. Even though current deadlines established by law and government policy may, in principle, not allow enough time to develop alternatives, much more time is likely to be available when public opposition delays the implementation of the current technical approach. However, workshop participants noted, it's important that the government doesn't make the same mistakes in developing alternative technologies as it did in picking the current one. That is, it mustn't be done in a process closed to the stakeholders and interested parties. Thus the *process* of developing a possible alternative technology will be as important as the pure technical solution itself. The process must involve the public early and continuously and must provide for meaningful public input to the decisions that are made.

Congressional concerns about the current program and its chances for success were discussed by workshop participants. Four committees in Congress have authority over the Army's Chemical Demilitarization program: Senate and House Committees on Appropriations (Subcommittee on Defense), and the Senate and House Committees on Armed Services. These committees do not all agree about the proper direction of this program, but its cost is becoming an increasingly important issue to all. Some feel that the eight sites where incinerators are planned are somewhat politically isolated-' them against the world. '

Implementation of an alternative technology development program may require a new, neutral institution other than the Army to administer it. Some participants believed that a location should be designated, probably by Congress, where new, competing technologies could be tried. An example might be to use a portion of the Johnston Atoll chemical Agent Disposal System facilities at Johnston Island, although the possibility of site contamination with agent would have to be evaluated. This facility is already designed to handle the CW munitions and agents.

National Research Council (NRC) activity was also discussed at the workshop. The NRC has a Committee on Alternative Chemical Demilitarization Technologies, under the Board on Army Science and Technology, chaired by John Longwell (MIT) and Gene Dyer (Bechtel). The committee plans to review all proposals for alternative technologies and to identify the most promising ap-

preaches. It will ask the scientific and commercial community to come forward and present their ideas. The committee will characterize the alternatives, enumerating their strengths, weaknesses, potential advantages and disadvantages, and needed research. It is possible that these NRC committee activities will become beginning steps of new national alternatives for CW destruction program, even though this is not the intention now. The NRC expects to develop a data bank to which others will have access. The OTA workshop participants suggested that the NRC also deal with the key issues of public participation in its work. However, its position as a purely scientific body may make this difficult.

The NRC committee considers that an alternative technology must have application to one or more of the four process streams currently used to destroy agent and munitions. Considering the sites, and the nature of the chemical stockpile located therein, it's possible that one or more alternatives (in combination) could apply. Whatever the case, a total working system is required in the end, and the system eventually developed must be the result of a series of reevaluations and corrections. Workshop participants agreed that only after integration and conceptual system design is done will it be possible to compare the merits of alternatives to the current system. It is very difficult, as well, to compare technologies that are in early stages of development. Usually more design, testing, and evaluation work is needed before valid comparisons are made and NRC does not have the resources to do this.

During discussions of public participation and alternative technology criteria, workshop participants agreed that different solutions may be appropriate for different sites or different weapons. The Army and concerned citizens would need to work together on establishing site-specific solutions if that approach was followed. Such public participation is crucial to acceptance of a solution: merely an explanation of risk to the public is generally ineffective. Participants all stated that the development of a new technology is more than just a technical problem, and the nontechnical community must be involved in a successful program.

A common nontechnical community position is that the technical community does not have the right to impose any risks on the affected public. The problem is that the U.S. public is unwilling to accept any risk that they did not consent to. The criteria for a new technology are only partially technical, and also involve managerial, legal, and other nontechnical aspects that all must be addressed for a successful program. A critical point is that the developers of the new technology need a very clear concept of the needs and concerns of the people who will be affected by the new technology. Workshop participants felt the current Army program lacks this concept.

Workshop discussions led to the conclusion that without local involvement most projects involving "waste disposal" are likely to be vehemently opposed. However, this may or may not change with community involvement. In addition, the agenda of national groups may be different than that of local groups and probably should be handled differently. With regard to the Army's CW destruction program, most believed that alternatives should be developed—the only question is how. The Nation's ability to carry this out will reflect on its ability to function as a technical society in the next century.

Workshop participants also discussed the role of contractors. Contractors are a key interested party that should be involved in planning the development of new technologies. Contractors also have their own agendas and preferences. The contractor community also needs to know, and factor in, the political realities, i.e., general unpopularity of incinerators. Although the CW disposal program will require oversight from government agencies, the design and implementation will probably come from private industry. The Environmental Protection Agency (EPA) is developing a computer database on available vendors and technology for alternative technology development in a number of waste treatment areas. Most believe that we need some model on how to commercialize a technology in order to move ahead in this field.

Some workshop discussion focused on the fact that good ideas from small companies often have a difficult time penetrating the Federal procurement system. These companies will need assistance to do this effectively. The small developers of new technologies typically have annual revenues of a few million dollars and are not capable of financing major development and testing. Small companies are often willing to try new solutions for relatively very small amounts of money. However, small companies often lack a necessary understanding of the whole system. A second concern of small companies is their need to protect ownership of new, innovative ideas that they consider proprietary.

A suggested model by some workshop participants was to offer a national prize for the best solution to this problem. This would not necessarily be to invent a totally new process but rather to work out the technical details of currently available techniques. It could have the effect of turning loose competent engineers to work on the problem. Possibly it could be a joint project with unemployed Soviet scientists. A disadvantage to this idea is that small companies may not be able to participate as well as large ones.

The university consortia concept was another suggestion discussed as a mechanism to develop alternatives. EPA has developed such consortia with five universities receiving \$5 million over 5 years. EPA feels that the

universities are bringing new ideas to the stage of bench-scale testing in about 3 years.

Workshop discussion of regulatory issues affecting the implementation of a new technology concluded that these issues should be anticipated at the earliest stage, rather than waiting until the last minute to worry about them. Many development programs do not include regulatory issues until they are ready for field trials, and then projects are surprised by the delays they encountered. Some regulations are developed purely as a means to thwart an unpopular technology. It would be worthwhile to learn from the Army's experience about the regulatory issues it has had to deal with in its current program. In the end, regulatory issues can make or break a technology.

A key criterion for the development of new technologies is meeting appropriate standards. This will apply to levels in air, liquids, and solids. Different alternative technologies will require different disposal criteria. For example, certain processes may provide less decontamination for CW containers and it will be necessary to understand how to integrate regulatory standards early in the development process.

Substantial workshop discussion focused on time constraints for the Army's Chemical Weapons Demilitarization Program. The time issue is critical in alternative technology development planning. One approach to an alternative program could be to try and find mid-term corrections for the Army's current system, e.g., replacing some or all of the incinerators with some other method but keeping everything else. Another would be to start over with an entirely new system. The impact on the Army's current program clearly will be quite different with these two approaches. A sense of time constraints will also dictate where a new program can begin. For example, if lots of time is available then a new program could afford to begin in the laboratory; if less time is available then a new program would probably be forced to consider only existing bench-scale technologies or technologies already tested in related areas. In addition, it maybe premature to try and be definitive in estimating the time required for successful completion of the Army's current program. Technical and regulatory hurdles faced by the program may delay it more than what has been estimated. Replacing incineration with some other CW agent treatment technology at this point could be considered by some a "mid-term" modification.

Most workshop participants agreed that a clear analysis of time constraints is required. This should include an analysis of the costs of delay, the risks of delaying, the degree of uncertainty and other factors, and how to evaluate them.

Workshop discussions explored examples of analogous alternative technology programs. After the *Valdez* oil spill in Alaska, bioremediation companies saw the

situation as a golden opportunity. One workshop participant explained the recent experience of the National Environmental Technology Applications Corp. (NETAC, see box I-D), which served as an evaluator for EPA and also put together a national committee that established technical and nontechnical criteria to evaluate hundreds of suggestions. This process narrowed the field to two alternatives that were eventually tested in the field. The tests involved importation of bacteria not indigenous to Alaska, despite the concerns of Alaska citizens. This was accomplished by incorporating public participation in the decisionmaking process and explaining the relevant technology to the public. A key to the success of this program was to initially develop a set of seven key criteria with public involvement for the evaluation of suggested technologies.

Another example given by a workshop participant was the alternative fuels development program, e.g., oil shale conversion. This is an example of a new technology that started from scratch. The Synthetic Fuels Demonstration program eventually produced six major demonstration projects, but the program eventually failed for financial reasons when the price of oil went down. Shale oil would have been competitive only if oil prices continued to go up, which they didn't. The lesson of this example is that a powerful national interest can significantly accelerate a program.

Discussions also included some history of incineration in the United States. Incineration was initially perceived as a panacea for waste treatment. As instrumentation got better and real experience was gained, unanticipated problems with incineration were discovered. A similar progression may be occurring today with bioremediation, which initially looked as a promising, benign method for handling waste. Today, people are beginning to ask about potential hazards from intermediates and byproducts of bioremediation processes.

Even though most believed that it is desirable and even essential to sponsor an alternative technology development program, workshop participants felt it important to understand the risks of such an effort. The prospects for success of an alternative program are not assured. There could always be a number of technical problems and delays associated with any development program. Failure of a technology or approach in a full-scale test is always possible. After even the best efforts to develop new technologies, it is possible that the results could be no better or even worse than the current system.

Therefore, if an alternative development program was supported it would not necessarily follow that the current program should be stopped. It may be possible to combine the best features of both programs in the future or it may be that current technologies will be superior to any alternatives in the end.

Workshop participants agreed that it is not clear whether future degradation of the weapons in the stockpile poses a significant threat and, thus, how this would affect decisions about time available for initiating de-

struction. An important issue, therefore, is a continuing program to evaluate stockpile condition and predict any future problems.